

Operation Manual for The O1100+ Series Column Oven

V1.0.0

Statement

The manual describes various contents of the O1100+ series column oven. It is intended to help users to understand, use and maintain the instrument of the O1100+ series. Elite does not assume the responsibility caused by the manual.

The manual is subject to change without notice.

The manual has been carefully reviewed at the time of published, it is believed to be accurate and complete. Elite is not responsible for any error that may appear in the manual and the resulting incidental or renewal of harm.

In any case, Elite does not responsible for the impact caused by the use of the manual and equipment.

The manual Copyright owned by Elite. Without the authorization of the company, any unit and individual shall not copy, reprint or reproduce this manual in whole or in part.

Precautions

Thank you for your continue patronage. Observe the following precautions in order to make safe and stable use of the instrument.

Precautions are divided into three groups in this operation manual depending on the degrees of danger. The three groups are



[Warning] Failure to properly follow the instructions and precautions indicated by this sign can result in serious injury or damage to health and property. The property damage includes the environment around and the instruments.



[Caution] Failure to properly follow the instructions and precautions indicated by this sign can result in slight injury or damage to health and property. Slight injury does not require hospitalization. Slight property damage means the instruments can be recovered through simple maintenance.



[Note] The sign is used to help users operate the instrument properly, otherwise it will cause unnecessary damage to the instrument or the correct experimental results will not be obtained.

1. Precaution for usage



[Warning] The O1100 Series Column Oven should only be used as a part of liquid chromatography. Do not use it any other purpose. Except for special instructions, the instrument does not have explosion-proof function.

2. Precaution for the ambient



[Warning] When the organic solvents are used, it is recommended that interior must be well ventilated, the firework should be prohibited. Also, a sink or equipment for washing eyes should be installed nearby in case of the organic solvent coming into contact with the eyes or skin.



[Note] In order to ensure good efficiency, keep the instrument away from caustic gas and dusty environment. The worktable should be neat, smooth, firm, and big enough. Ambient is between 10°C to 30°C with a small fluctuation, and RH is between 45% to 85%. Avoid it from cold or hot source as well as direct sunshine. The system should not close to strong magnetic field.

3. Precaution for installation



[Warning] The instrument should be installed following the instructions strictly by professionals, make sure that the voltage of the power socket is the same as the power supply voltage indicated on the instrument. Using the wrong power voltage could result in danger and fire.

The accessory power cable should be used to connect the instrument to the power socket. Other cable should not be used.

The equipment should be connected with protective earth to prevent static and leakage.



[Caution] The instrument is so heavy, you should move it carefully and watch your hands at the same time.



[Note] The instrument should be connected following the instructions strictly. Wrong connection could cause communication error.

4. Precaution for use



[Warning] Do not use the instrument in places where heat resource, fire seat, magnetic resource, strong vibration exist or may exist. It is prohibited to play flammable nearby.

The bottle for storing the mobile phase should have pore in cap to prevent danger cause by negative pressure in the bottle.

A gap between waste tube and the cork of waste bottle is necessary to prevent the waste bottle bursting when it is overfilled. The gap should be smaller to insure less evaporate of hazardous solvents. Even though, the waste needs to be clean up promptly.



[Caution] When using organic solvents, please wear safety goggles, special lab coats, gloves mask etc.. If your body contact with toxic solvent accidentally, wash it immediately, and then go to hospital for specialized treatment.



[Note] When preparing mobile phase, please use HPLC-grade or equivalent at this level solvents. Solvents must be prefiltered by the manufacturer with 0.45 μ m (or smaller) filter paper. Degas all mobile phase before using it. Degassing can help to ensure a stable baseline and consistent analytical results.

Before first use, rinse the entire piping system according to the requirements of the manual, direct use is likely to block pipeline.

Before sample test, ensure that the pipeline in the system is filled with mobile phase without any bubble, otherwise it will affect the reliability of test results.

If an eluent is replaced with another eluent in which is insoluble, such as positive mobile phase (hexane) and reverse phase (methanol), be sure to use transition solvents (isopropanol) as specified in the manual, otherwise it will cause serious pipeline jam, and even system paralysis.

Do not use the following solvent: concentrated sulfuric acid, nitric acid, dichloroacetic acid, methylene chloride, chloroform, dimethyl sulfoxide, acetone, tetrahydrofuran, etc. Such solvents always reduce the strength of the PEEK material, make it become fragile and broken, but short-term use of aqueous solution of acetone (lower than 0.5%) in gradient performance, the impact is acceptable.

When using PEEK pipes, the press of system should be lower than the tolerance pressure of peek material, otherwise it may burst.

The bending radius of peek pipe should be more than 10mm, make the peek pipe natural relaxation during installation.

The PEEK pipe should be intercepted with professional tube cutter in order to make the pipe more smoothly. Pay attention to that there is no cutting debris left in the pipe.

5. Repair, maintenance and parts replacement



[Warning] Before repair, maintenance and parts replacement, please turn off the power in case of leakage and electric shock.

There is no need to open the host cover while daily maintenance and repair. If the repair need to open the host cover, please entrust agents or communicate with us.

Use dry close to wipe the instrument. Do not use water or alcohol. The use of these liquids may erase characters or color on the panel.

Do not replace parts (e.g., fuses, deuterium lamp, etc.) from other company or other type, all accessories are required to be specified to prevent danger.

6. Precaution for static electricity



[Warning] As this pump may use a lot of flammable, explosive organic reagents which can contaminate laboratory air. When the reagent concentration is too high, any spark or flame could cause fire or explosion accidents. Do not use the pump near any fire resource, hot resource, and static electricity resource. To reduce static electricity, please take the following measures:

- 1) Make the instrument grounded. It is very important, please pay attention to it.
- 2) Maintain proper indoor humidity (humidity is greater than 65% can prevent static electricity effectively). Keep the environment clean.
- 3) Metal waste bottles (external conductive) should be grounded (no ground insulation). When using other materials container, you can insert one end of the wire into liquid in the bottle and make the other end is grounded.
- 4) Replace thicker pipe when the flow of the mobile phase is large.
- 5) Wipe the instrument regularly.
- 6) Staff wear anti-static clothing, anti-static mats is needed on the floor.
- 7) People and objects with static electricity is prohibited to touch the instruments.

7. Warning label instructions

To ensure the safety of staff, we attach warning labels on the equipment where is danger. If the label is missing, please request new ones from the company, and attach to the correct position.

Contents

Chapter One: Introduction	1
1.1 Overview	1
1.2 Features and Functions	2
1.3 Performance Specification	2
1.4 Physical Specifications	2
Chapter Two: Installation and transport	3
2.1 Unpacking inspection and standard accessories	3
2.2 Installation Requirements	4
2.3 Tube Connection	6
2.4 Transportation	8
Chapter Three: Basic Operation	9
3.1 Power On	9
3.2 Basic Operation	9
Appendix	I
Introduction to the connecting tube materials	I
Safety information	II
General safety information	II
Standard of security	II

Chapter One: Introduction

1.1 Overview

The O1100+ series is a high-performance and cost-effective liquid chromatography column constant temperature box developed by Elite Company based on years of production experience in constant temperature boxes.

The O1100+ series chromatographic column constant temperature box, as the temperature control unit of this series of high-performance liquid chromatographs, can be conveniently used in conjunction with various liquid chromatography units or independently as a temperature control device. The O1100+ series includes two models: O1110+ and O1120+. The O1110+ features a circulating air function, which not only shortens the heating time but also significantly reduces the temperature gradient. Increase the length of the chromatographic column constant temperature box to accommodate two ID10mm×300mm chromatographic columns. The O1120+ not only has the function of circulating air but also adds 485 communication function.

In addition to the O1100+ series chromatographic column incubator, the Agress 1100+ series of high-performance liquid chromatographs also includes instrument accessories such as the D1100+ UV/VIS Detector, P1100+ P1100+ High Pressure Constant Flow Pump , and T1100+ Solvent Tray.



Figure 1-1: O1110+ column oven



Figure 1-2: O1120+ column oven

1.2 Features and Functions

Imported temperature controllers and sensors make temperature control more precise and stable.

The integrated structure is more convenient to use.

The heating element adopts advanced membrane heating, which extends the service life several times.

It has 485 communication function (O1120+)

1.3 Performance Specification

Table 1-1: Performance Specification for O1100+ series

Item	Specification
Temperature range	Ambient temperature+5°C~99 °C
Setting precision	0.1°C
Temperature accuracy	≤ ±0.5°C
Temperature stability	≤0.2°C

1.4 Physical Specifications

Table 1-2: Physical Specification for O1100+ series

Model	Weight	Power	Consumption	Dimension	Communication
O1110+	4.2 Kg	AC 220V(±10%), 50Hz	110	120mm×65mm×570mm (L×W×H)	Not have
O1120+	4.2 Kg	AC 220V(±10%), 50Hz	110	120mm×65mm×570mm (L×W×H)	Have

Chapter Two: Installation and transport

2.1 Unpacking inspection and standard accessories

O1100+ series is packaged with corrugated boxes and foam lined structure, as you receive the instrument, check the packaging first, if you found packaging is damaged, please contact with Elite or local dealer.



[Warning] If there is any damage to the instruments when you receive it, please don't try to install it. You can ask Elite to inspect and assess it.

2.1.1 Unpack

Put the instrument on level ground with the face of the packing box up. Cut the tape on the top, take out the column oven and accessories package, place it on the table. Then, remove foam, open the instrument protective film.



[Warning] It is suggested that installation operation should be careful to prevent instrument slide.

2.1.2 Deliver checklist

Before installing, please check the deliver list carefully, if one or several of them omissions, please communicate with Elite or local distributors as soon as possible.

Table 2-1: Deliver list of O1100+ series column oven

NO.	Item	Quantity
1	O1100+ series column oven	1 pc.
2	Certificate	1 pc.
3	Start Package	1 pc.



[Note] If there is discrepancies between the packing list in the box and in the specification, please refer to the packing list in the box, It is subject to change without prior notice.

2.2 Installation Requirements

2.2.1 Site Requirements

Environment

O1100+ series column oven need to work under ambient conditions in Table 2-2 below:

Table 2-2: Environment requirements

Item	Specification	Requirements
1	Work environment	Room should be free of dust, inflammable and explosive materials, also, good ventilation is important
2	electromagnetic field	No electromagnetic noise nearby
3	Operating temperature	4~40°C (39~104°F)
4	Humidity	20%~80%, non-condensing
5	Temperature fluctuation	< ± 2°C /hr



[Caution] Do not use the column oven under conditions of temperature fluctuations.

If the ambient temperature is too low, make the room temperature increase slowly to avoid condensation inside caused by rapid heating.

Bench space

The O1100+ series chromatographic column constant temperature box can be placed on a normal desktop or laboratory bench. If a complete Agress 1100+ system is to be placed on the workbench, it is necessary to ensure that the workbench can bear the weight of all components. Additionally, about 5cm of space should be left on the left side, about 15cm on the right side, and about 15cm at the back to facilitate air circulation and power cord connection.



[Warning] The instruments should be placed on a horizontal position, otherwise there is a danger of falling!

2.2.2 Power and power line

To ensure the instrument can be normal and safe, please use a dedicated power line within the specified voltage range.

- Grounding, AC power to 220V \pm 10%, 50 Hz;
- Please select T1.25A (250V) fuse



[Warning] The accessory power cable should be used to connect the column oven with the power socket. Other cable should not be used in case of danger or damage to the instrument.

If the instrument is connected to a grid above the scope of application, it may cause electrical shock or damage to the equipment and staff.

Please unplug the power cord before replacing the fuse to avoid electric shock. The external fuse is installed in the back of instrument.

2.3 Tube Connection

In addition to the column system, piping, fittings and injector, detector volume are likely to cause bands broadening. Inappropriate tube material also leads to band broadening, even lead to degeneration of the sample. Please connect the tubes with instruments correctly to improve efficiency.

O1100+ series column oven can accommodate two chromatographic columns whose ID is 4.6mm×300mm at most, or one column whose ID is 10mm×300mm at most. If you need to connect a protect column, circuitous type connection is a good choice.

2.3.1 Tube material

Different material of tube is required according to the working pressure, the kind of mobile phase and the nature of sample. The tube materials used commonly are as follows: stainless steel, polyetheretherketone (PEEK), polytetrafluoroethylene, polyethylene or polypropylene in which the most commonly used material is stainless steel. The outer diameter of LC connection tube is 1.59mm (1/16 "), the inner diameter of LC tube are 0.175mm (0.007"), 0.25mm (0.01 "), 0.5mm (0.02"), 0.75 (0.03 ") mm and 1.0mm (0.04") etc., users can choose from them.

Stainless steel tube is generally used for high-pressure part. In the liquid chromatography system, from the pump outlet to the chromatographic column inlet belongs to the high-pressure part, stainless steel tubes must be used. The stainless steel pipe has good corrosion resistance and precise coaxiality. When selecting it, attention should be paid to the matching of the pipe hole and the joint hole.

Polymer tube can be used in low-pressure part of LC System, such as from reservoir bottle to pump, detector outlet, injector discharge port, etc.. Polymer tube is the most common connection tube in LC system.

PEEK tube can withstand about 30MPa pressure, it is more inert than stainless steel pipe which means it is a good choice for separation, analysis and preparation of biological samples. In bio-separation system, PEEK is alternative materials for stainless steel.

2.3.2 Cleaning the connect tube

Please wash new pipeline with solvent before use. Cleaning order: chloroform - methanol (ethanol) - Water - 1mol/L nitric acid - water - methanol - dry with nitrogen stream. Also, silicone tube should be rinsed with methanol before use.

2.3.3 Structure of equipment

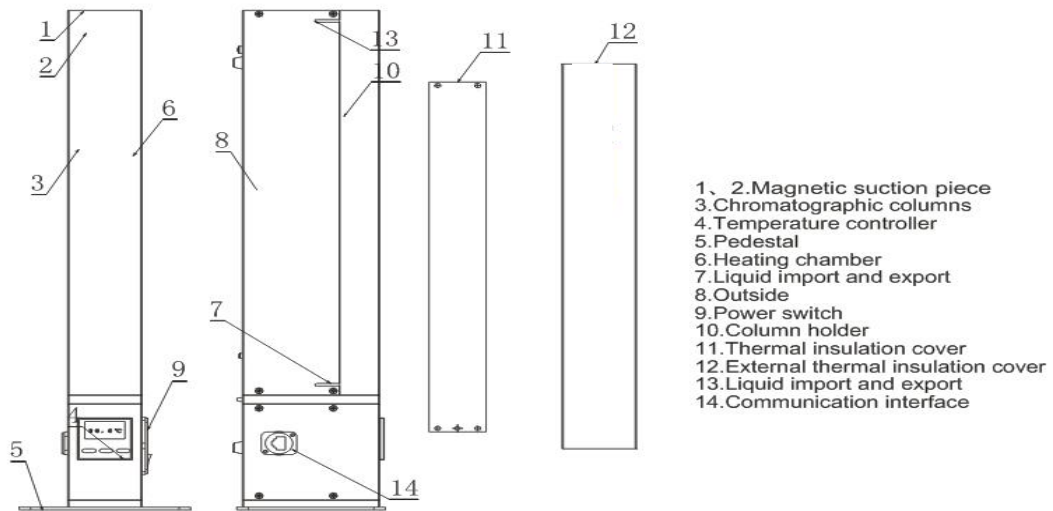

Figure 2-1: O1110+&O1120+ Column Oven diagram



[Note] The pedestal should be installed when the chromatographic column thermostat is placed vertically.

2.4 Transportation

Column oven is a precision instrument, please be gentle while long-distance transportation, severe vibration, drops are likely to cause damage to the internal parts of the instrument. The random original packaging can effectively protect the instrument. When the instrument is required to move or returned for service, please follow these steps for packaging.

Turn off the power.

Unplug the power cord and communication lines.

Remove the connecting pipe and other elements between components.

Remove the column oven from chromatography system, and then put it into special sealed bag on a large platform.

Put the column oven into the original packaging foam and fix it.

Place the fixed column oven and other accessories into original packaging carefully.

Tape the box sealed to prevent liquid from entering. Cover the packaging box with plastic wrap is recommended.

Transport packaged instrument.



[Warning] Before packing, please check the box, if the original packaging has been damaged, do not use it, you should consult your local dealer or Elite customer service staff to solve!

Chapter Three: Basic Operation

3.1 Power On

Please plug the power cord into the power outlet.



[Caution] The power switch is turned off at this time.

Turn on the power switch (on the left of the temperature controller).

3.2 Basic Operation

The normal operation button of the column oven O1110+&O1120+ is showed in figure 3-1

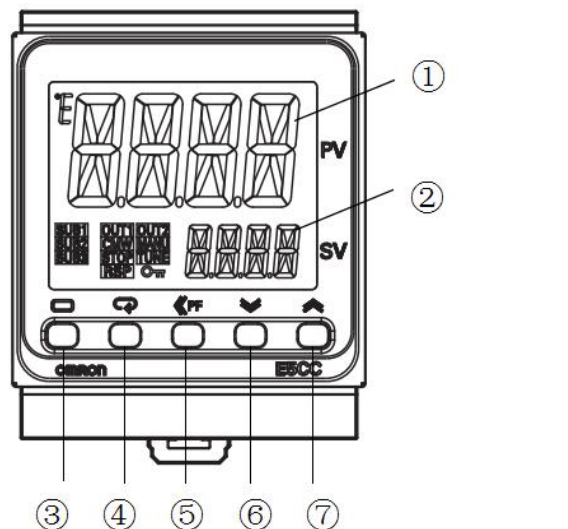

- 1 Actual temperature 2 Setting temperature 3 menu key
4 Model setting key 5 Shift key 6 Down key 7 Rise key

Actual temperature: The actual temperature of the column oven.

Setting temperature: The setting temperature of the column oven.

Menu key: Use this key to switch menus

Mode setting key: Press this key to change the real content, press this key to display the content in reverse direction for more than 1 second

Shift key: The PF setting parameter is set to shift digits by default. This key is a function key. When this key is pressed, the PF parameter setting function takes effect

Down key: To reduce the setting temperature by pressing it in the main screen.

Rise key: To rise the setting temperature by pressing it in the main screen.



[Caution] The default parameters is already the best temperature control parameters, In addition to the special circumstances, the user do not need to reset.

Appendix

Introduction to the connecting tube materials

In HPLC systems, column system, piping, fittings, and outside the injector and Extra-column of detector are likely to cause peak broadening. Improper tube material will also lead to peak broadening, even causes the sample degeneration, which affects the reliability of analysis results directly.

Good connection can fully exert the function of the instrument, improve the work efficiency. Different pipeline material is needed according to system pressure, properties of mobile phase and samples. Commonly used pipe materials including stainless steel, polyether ether ketone (PEEK), teflon, poly (vinylidene fluoride), polyethylene or polypropylene, the stainless steel pipe is most commonly used.

Outer diameter of HPLC system is 1/16"(1.59mm). Inside diameter can be chosen according to your need, Commonly used inside diameter including 0.007"(0.175mm) , 0.01"(0.25mm) , 0.02"(0.5mm), 0.03"(0.75mm) and 0.04"(1.0mm) etc..

Stainless steel tube is generally used in high pressure part. In HPLC systems, from the pump discharge to column inlet part is high pressure section, stainless steel tube is recommended.

Stainless steel tube has good corrosion resistance and coaxiality, bore pipe and joint should be match well while using it.

Also, polymer tube can be used in many sections of HPLC system, such as low pressure parts: from liquid bottle to export pump, detector and sampler drainage mouth, emptying valve outlet and others. Teflon is inertial to HPLC solvent and is the most commonly used plastic pipe.

When the pressure is lower than 20MPa, peek tube is lazier than stainless steel tube and is more suitable for biological sample analysis.

Safety information

General safety information

At the different stages of the instrument operation, maintenance and repair, everyone should abide the following general safety rules, breaking these rules may cause damage to instruments or staffs, Elite does not responsible for the impact caused by non-standard operation.

Standard of security

For marked with this symbol of the equipment, the user should refer to the instruction manual, so as not to cause harm to the operator and equipment.

Symbol	Description
	Please do not operate beyond the scope of caution, unless you have been fully understand and meet the required conditions.
[Warning]	Casualties may appear. Please do not operate beyond the scope of warning, unless you have been fully understood and meet the required conditions.
[Caution]	Data loss or equipment damage may appear. Please do not operate beyond the scope of caution, unless you have been fully understood and meet the required conditions.
[Note]	Unsatisfactory experimental data and instrument failure may appear. Please do not operate beyond the scope of note, unless you have been fully understood and meet the required conditions.

ELITEHPLC

About Elite

Suzhou Elite Science & Technology Co., Ltd.
701#, Building 10, Liandong U Valey, No. 179 Zhujiawan Street,
Gusu District, Suzhou, Jiangsu, China.
Tel: +86-512-67997535
E-mail: info@eliteHPLC.com
Web: <http://www.elitehplc.com>
