

Operation Manual
for P3200L Series High Pressure
Constant Flow Pump

V1.0.4

Statement

The manual is intended to help users to understand, use and maintain EClassical P3200L Series pump. Our company does not assume the responsibility caused by business or special purpose use of the manual.

The information in this document is subject to change without notice and should not be construed as a commitment by Our company.

This manual is believed to be complete and accurate at the time of publication. Our company assumes no responsibility for any errors that may appear in this document.

In no event shall our company be liable for incidental or consequential damages in connection with, or arising from, the use of this manual.

The Copyright of the manual is owned by our company. This book or parts thereof may not be reproduced in any form without the written permission of our company.

Please read the document carefully before using the pump.

Foreword

Thank you for purchasing our equipment. To ensure correct and safe use of the instrument, please read it carefully before using.

The details of the equipment's composition, installation, method of using, maintenance, parts selection and other points are described in the manual. After reading, please keep it carefully. Please delivery the manual with the instrument.

For safe operation, please read the following **Safety Precautions** before using the instrument.

Safety Precautions

According to the level of danger and harm, safety signs here are divided into the following three categories:



[Warning] Failure to properly follow the instructions and precautions indicated by this sign may result in serious injury or damage to health and property. The property damage includes the environment around and the instrument.



[Caution] Failure to properly follow the instructions and precautions indicated by this sign may result in slight injury or damage to health and property. Slight injury means no hospitalization is needed to the wounded. Slight property damage means the instrument can be recovery through simple maintenance.



[Note] The sign is used wherever information is given to ensure optimal performance of the instrument.

1. Precaution for usage



[Warning] EClassical P3200L Series pump should only be used as a part of liquid chromatography. Do not use it for any other purpose. Except for special instructions, this instrument does not have explosion-proof function.

2. Ambient Conditions



[Warning] When we use organic solvent it is recommended that interior must be well ventilated and the firework should be prohibited. Also, a sink or equipment for washing eyes should be installed nearby in case of the organic solvent coming into contact with the eyes or skin.



[Note] In order to ensure good efficiency, keep the instrument away from caustic gas, dusty environment or strong magnetic. The worktable should be wide and strong enough. Ambient should be between 4°C to 40°C with a small fluctuation, and humidity should be between 20% to 80%. Avoid it from cold or hot source as well as direct sunshine. The air conditioners and other equipment should not blow directly into the instrument.

3. Precaution for installation



[Warning] The instrument should be installed following the instructions strictly by professionals, make sure that the voltage of the power socket is the same as the power supply voltage indicated on the instrument. Using the wrong power voltage could result in danger and fire.

The accessory power cable should be used to connect the pump to the power socket. Other cable should not be used.

Make sure the line cord is connected to a properly grounded power receptacle to prevent static and electric leakage.



[Caution] The instrument is so heavy that you should move it carefully and watch your hands in the same time.



[Note] The instrument should be connected following the instructions strictly. Wrong connection could cause communication error.

4. Precaution for use



[Warning] Do not use the instrument in places where heat resource, fire seat, magnetic resource, strong vibration exist or may exist. It is prohibited to put flammable nearby.

The bottle for storing the mobile phase should have a pore in cap to prevent the danger caused by negative pressure in the bottle.

A gap between the waste tubing and the cork of the waste bottle is necessary to prevent the waste bottle bursting when it is overfilled. But the gap should be small to prevent evaporate of hazardous solvents. Even though, the waste needs to be clean up promptly.



[Caution] When using organic solvents, please wear safety goggles, special lab coats, gloves mask etc. If your body contact with toxic solvent accidentally, wash it immediately, and then go to hospital for specialized treatment.



[Note] When preparing mobile phase, please use HPLC grade solvents or equivalent ones. You'd better filtrate the eluent with a membrane filter (0.45 μ m), and an online filter is also necessary to prevent small particles from scratching plunger rod, seal ring or blocking tubing. What's more, please degas all mobile phase before using, degassing is an effective method to prevent chromatogram noise and wrong indicator.

Before first use, rinse the entire piping system according to the requirements of the manual. Direct use is likely to block tubing.

Before sample test, ensure that the tubing in the system is filled with mobile phase without any bubbles, otherwise it will affect the reliability of test results.

If an eluent is replaced with another eluent which is insoluble, such as positive mobile phase (hexane) and reverse phase (methanol), be sure to operate according to the specified method in the manual, otherwise it will cause serious tubing jam, and even system paralysis.

Halogen ions is harmful for stainless steel, if there is stainless steel tubing and fitting in your system, please avoid the use of a mobile phase containing halogen ions. If you can't avoid it, please minimize the content and clean the system with water as soon as finishing the analysis.

If there is PEEK tubing in your system, it is important to note that:

Do not use the following solvent: concentrated sulfuric acid, nitric acid, dichloroacetic acid, dichloromethane, trichloromethane, chloroform, dimethyl sulfoxide, acetone, tetrahydrofuran, etc. Such solvents can reduce the strength of the PEEK material, make it's become fragile and broken. But the impact of short-term use of aqueous solution of acetone (lower than 0.5%) in gradient performance is acceptable.

When using PEEK tubing, the pressure of the system should be lower than the tolerance pressure of PEEK material, otherwise it may burst.

The bending radius of PEEK tubing should be more than 10mm, make the PEEK tubing natural relaxation during installation.

The PEEK tubing should be intercepted with professional tubing cutter in order to make the tubing more smoothly. Pay attention to that there should be no cutting debris left in the tubing.

5. Repair, maintenance and parts replacement



[Warning] Before repair, maintenance and parts replacement, please turn off the power in case of leakage and electric shock.

There is no need to open the host cover while daily maintenance and repair. If the repair needs to open the host cover please entrust agents or communicate with us.

You should clean the dust on the power cord plug regularly to reduce the electrostatic. Then, dry it before using, otherwise electric shock may occur.

Use dry cloth to wipe the instrument. Do not use thinner or alcohol to avoid erasing characters or color on the panel.

Do not replace components (e.g., fuses, deuterium lamp, etc.) from other company or other type, all accessories are required to be specified to prevent danger.

6. Precaution for static electricity



[Warning] As the instrument may use a lot of flammable, explosive organic reagents which may contaminate laboratory air, when the reagent concentration is too high, any spark or flame could cause fire or explosion accidents. Do not use the pump near any fire resource or hot resource, and keep reducing the electrostatic in mind. To reduce static electricity, please take the following measures:

- 1) Make the instrument grounded. It is very important, please pay attention to it.
- 2) Maintain proper indoor humidity (humidity is greater than 65% can prevent static electricity effectively) and keep the environment clean.
- 3) Metal waste bottles (external conductive) should be grounded (no ground insulation). When using other materials container, you can insert one end of the wire into liquid in the bottle and make the other end earthed.
- 4) Replace a larger I.D. tubing when the flow of mobile phase is higher than usual.
- 5) Wipe the instrument regularly.
- 6) Staffs should wear anti-static clothing. An anti-static pad is needed on the floor.
- 7) People and objects with static electricity is prohibited to touch the instruments.

7. Warning label instructions

To ensure the safety of staffs, we attach warning labels on the equipment where are dangerous. If the label is missing, please request new ones from our company, and attach to the correct position.

Contents

1. CHAPTER ONE: INTRODUCTION.....	1
1.1 OVERVIEW	1
1.2 FEATURES AND FUNCTIONS.....	2
1.3 PERFORMANCE SPECIFICATION	3
1.3.1 P3210L High Pressure Constant Pump	3
1.3.2 P3220L High Pressure Constant Pump	3
1.3.3 P3230L Quaternary Low Pressure Constant Pump.....	4
1.4 PHYSICAL SPECIFICATIONS	6
1.5 DEFINE WORKING PRINCIPLE.....	7
1.5.1 P3210L High Pressure Constant Pump	7
1.5.2 P3220L High Pressure Constant Pump	8
1.5.3 P3230L Quaternary Low Pressure Constant Pump.....	9
1.6 APPEARANCE OF THE INSTRUMENT	10
1.7 INSTRUMENT STRUCTURE AND LAYOUT	11
1.7.1 EClassical P3200L Front	11
1.7.2 EClassical P3200L Rear	13
1.7.3 Internal introduction of P3210L.....	14
1.7.4 Internal introduction of P3220L.....	15
1.7.5 Internal introduction of P3230L.....	16
2.INSTALLATION AND TRANSPORTATION	1
2.1 UNPACKING ACCEPTANCE	1
2.1.1 Unpacking.....	1
2.2 STACK ORDER	2
2.3 INSTALLATION REQUIREMENTS	3
2.3.1 Site Requirements	3
Power and power line	4
Computer requirements.....	4
2.4 CIRCUIT AND COMMUNICATION CONNECTION	6
2.4.1 Circuit connection	7
2.4.2 Communication connection	7
2.5 FLUID CONNECTION SYSTEM.....	8
2.5.1 Tube use.....	9
2.5.2 Flow connection	10
2.6 PREPARATION FOR USE	15
2.7 VERIFICATION	16
2.7.1 Check the sealing performance	16
2.8 TRANSPORTATION	19
CHAPTER THREE: BASIC OPERATION	1
3.1 POWER ON	1
3.2 KROMSTATION WORKSTATION INSTALLATION.....	2
3.3 STARTING AND STOPPING THE PUMP	2
3.4 UNITS SETTING	6
3.5 SETTING METHOD FLOW RATE.....	7
3.6 SETTING SYSTEM PRESSURE AND SOLVENT NUMBER.....	9
3.7 MOBILE PHASE REPLACEMENT	10
3.7.1 Replacing with miscible liquid.....	10
3.7.2 Replacing with immiscible liquid.....	10
3.7.3 Replacing organic solvent with salt buffer	11

MAINTENANCE AND REPAIR	1
4.1 LED STATUS AND SIGNIFICANCE	1
4.2 PC ACTUAL FAULT ERROR CODE TABLE.....	2
4.3 TROUBLESHOOTING.....	3
4.3.1 <i>Elimination of Air Bubbles</i>	3
4.3.2 <i>Leakage of pump head</i>	3
4.3.3 <i>Overpressure</i>	3
4.3.4 <i>Pump not delivering solvent</i>	4
MAINTENANCE AND REPAIR	1
5.1 MAINTENANCE OF SOLVENT FILTERS.....	1
5.2 CLEANING TUBE	2
5.3 CLEANING THE CHECK VALVE	2
5.4 CLEANING THE ONLINE SOLVENT FILTER	5
5.5 CLEANING THE PUMP HEAD.....	6
5.6 PUMP HEAD ASSEMBLY.....	7
5.7 RELIEF VALVE SEAL REPLACEMENT.....	10
5.8 PERISTALTIC PUMP SILICONE TUBE REPLACEMENT	11
COMPONENTS AND MATERIAL LIST	I
6.1 CONSUMPTION PARTS	I
6.2 OPTIONAL PARTS	II
APPENDIX	III
INTRODUCTION TO THE CONNECTING TUBE MATERIALS	III
SAFETY INFORMATION	IV
<i>General safety information</i>	IV
<i>Standard of security</i>	IV

1. Chapter One: Introduction

1.1 Overview

P3210L high-pressure constant flow pump, P3220L/P3202L high-pressure constant flow pump and P3230L/P3203L quaternary low-pressure constant pump are two high pressure constant flow pump products in the EClassical P3200L series launched by o

ur company. As an infusion unit of an HPLC system, they are equipped with a variety of functional packages, which can be customized according to customer needs be optional.

P3200L series of high-pressure constant infusion pump unit as a high pressure liquid chromatograph of this series of constant flow, low flow pulsation; flow rate gradient accuracy, repeatability is a gradient, hysteresis small volume, a great degree of assurance repeated experiment. Provide mobile phase selection, mobile phase degassing and other functions, which can automatically complete the mobile phase replacement under unattended operation.

P3200L can be easily used with a variety of liquid chromatographic detectors, autosampler, column oven etc., and it also can be used independently as a delivery tool.

1.2 Features and Functions

Excellent Design

- Pump using FIFO manner that the liquid first flows into the pump head of the pump head priority, facilitate the replacement of the solvent, the removal of air bubbles, reducing system settling time;
- The plunger suspension design is beneficial to reduce the impact of the pump head plunger and the pump body push rod caused by assembly, and the conical spring is beneficial to reduce the swing of the plunger during operation and reduce the wear of the plunger;
- Flow double correction function, can adjust the mobile phase compression coefficient through software, and adjust the mobile phase adjustment coefficient in sections, which not only ensures the accuracy of single point output, but also effectively controls the full range of output;
- Multi-stage mixer is mixed with the porous labyrinth design, a more uniform mixing, help to reduce the pulsation generated when mixing small proportions;
- Passage optimize the design, reduce the impact on traffic system back pressure gradients.

Intelligent Systems

- The automatic POST function can detect the circuit failure of the high-pressure constant-current pump at the first time, avoiding unnecessary damage caused by it;
- Leakage alarm function, allows customers to find fault leakage flow path at the first time, to ensure a constant flow pump stable and reliable operation.

Diversified Functions

- The same set of frame and shell can be equipped with different types of infusion pumps according to user needs, reducing customer procurement costs;
- Three kinds of display modes combination of pressure units, to meet the requirements of different users and quality control.
- Optional degasser module and solvent selection module, user configuration flexibility, high integration.+

1.3 Performance Specification

1.3.1 P3210L High Pressure Constant Pump

Table 0-1: Performance Specification of P3210L pump

NO.	Items	Specifications
1	The solvent channels	one channel
2	Flow Rate	0.001mL/min~10.000mL/min (The step size:0.001 mL/min)
3	Accuracy	≤±0.2%(1.000mL/min,8.5MPa,water, ambient temperature) ≤±2.0%(0.001mL/min~10.000mL/min,8.5MPa,water, ambient temperature)
4	Precision	≤0.06%(1.000mL/min,8.5MPa,water, ambient temperature) ≤0.1% (0.100mL/min~10.000mL/min, 8.5MPa,water, ambient temperature)
5	Max Pressure	0.001~2.000mL/min 90MPa, 2.001~5.000mL/min 42MPa, 5.001~10.000mL/min 21MPa
6	Pressure accuracy	≤±3% or ±0.3 MPa
7	Pressure pulsation	≤0.1MPa (1.000mL/min,8.5MPa,water, ambient temperature)
8	Communication mode	TCP

1.3.2 P3220L/P3202L High Pressure Constant Pump

Table 0-2: Performance Specification of P3220L pump

NO.	Items	Specifications
1	The solvent channels	two channels
2	Flow Rate	0.001mL/min~10.000mL/min (The step size:0.001 mL/min)
3	Accuracy	≤±0.2%(1.000mL/min,8.5MPa,water, ambient temperature) ≤±2.0%(0.001mL/min~10.000mL/min,8.5MPa,water, ambient temperature)
4	Precision	≤0.06%(1.000mL/min,8.5MPa,water, ambient temperature) ≤0.1% (0.100mL/min~10.000mL/min,8.5MPa,water, ambient temperature)
5	Max Pressure	0.001~2.000mL/min 90MPa, 2.001~5.000mL/min 42MPa, 5.001~10.000mL/min 21MPa
6	Pressure accuracy	≤±3% or ±0.3 MPa
7	Pressure pulsation	≤0.1MPa (1.000mL/min,8.5MPa,water, ambient temperature)
8	Communication mode	TCP
9	Gradient ratio	0~100% Recommended use range 5~95%
10	Step mixing accuracy	±0.5%
11	Gradient mixing error	≤0.2%

Table 0-3:Performance Specification of P3202L pump

NO.	Items	Specifications
1	The solvent channels	two channels
2	Flow Rate	0.001mL/min~10.000mL/min (The step size:0.001 mL/min)
3	Accuracy	≤±0.2%(1.000mL/min,8.5MPa,water, ambient temperature) ≤±2.0%(0.001mL/min~10.000mL/min,8.5MPa,water, ambient temperature)
4	Precision	≤0.06%(1.000mL/min,8.5MPa,water, ambient temperature) ≤0.1% (0.100mL/min~10.000mL/min,8.5MPa,water, ambient temperature)
5	Max Pressure	0.001~2.000mL/min 70MPa, 2.001~5.000mL/min 42MPa, 5.001~10.000mL/min 21MPa
6	Pressure accuracy	≤±3% or ±0.3 MPa
7	Pressure pulsation	≤0.1MPa (1.000mL/min,8.5MPa,water, ambient temperature)
8	Communication mode	TCP
9	Gradient ratio	0~100% Recommended use range 5~95%
10	Step mixing accuracy	±0.5%
11	Gradient mixing error	≤0.2%

1.3.3 P3230L/P3203L Quaternary Low Pressure Constant Pump

Table 0-4:Performance Specification of P3230L pump

NO.	Items	Specifications
1	The solvent channels	four channels
2	Flow Rate	0.001mL/min~10.000mL/min (The step size:0.001 mL/min)
3	Accuracy	≤±0.2%(1.000mL/min,8.5MPa,water, ambient temperature) ≤±2.0%(0.001mL/min~10.000mL/min,8.5MPa,water, ambient temperature)
4	Precision	≤0.06%(1.000mL/min,8.5MPa,water, ambient temperature) ≤0.1% (0.100mL/min~10.000mL/min, 8.5MPa,water, ambient temperature)
5	Max Pressure	0.001~2.000mL/min 90MPa, 2.001~5.000mL/min 42MPa, 5.001~10.000mL/min 21MPa
6	Pressure accuracy	≤±3% or ±0.3 MPa
7	Pressure pulsation	≤0.1MPa (1.000mL/min,8.5MPa,water, ambient temperature)
8	Communication mode	TCP
9	Gradient ratio	0~100% Recommended use range 5~95%
10	Step mixing accuracy	±1.0%
11	Gradient mixing error	≤0.2%

Table 0-5:Performance Specification of P3203L pump

NO.	Items	Specifications
1	The solvent channels	four channels
2	Flow Rate	0.001mL/min~10.000mL/min (The step size:0.001 mL/min)
3	Accuracy	≤±0.2%(1.000mL/min,8.5MPa,water, ambient temperature) ≤±2.0%(0.001mL/min~10.000mL/min,8.5MPa,water, ambient temperature)
4	Precision	≤0.06%(1.000mL/min,8.5MPa,water, ambient temperature) ≤0.1% (0.100mL/min~10.000mL/min, 8.5MPa,water, ambient temperature)
5	Max Pressure	0.001~2.000mL/min 70MPa, 2.001~5.000mL/min 42MPa, 5.001~10.000mL/min 21MPa
6	Pressure accuracy	≤±3% or ±0.3 MPa
7	Pressure pulsation	≤0.1MPa (1.000mL/min,8.5MPa,water, ambient temperature)
8	Communication mode	TCP
9	Gradient ratio	0~100% Recommended use range 5~95%
10	Step mixing accuracy	±1.0%
11	Gradient mixing error	≤0.2%

1.4 Physical Specifications

Table 1-4: Performance Specification of P3210L pump

NO.	Items	Specifications
1	Weight	20kg
2	Dimension	600×380×180 (mm)
3	Power Supply	220V/50Hz
4	Power	45VA

Table 1-5: Performance Specification of P3220L/P3202L pump

NO.	Items	Specifications
1	Weight	23kg
2	Dimension	600×380×180 (mm)
3	Power Supply	220V/50Hz
4	Power	90VA

Table 1-6: Performance Specification of P3230L/P3203L pum

NO.	Items	Specifications
1	Weight	16kg
2	Dimension	600×380×180 (mm)
3	Power Supply	220V/50Hz
4	Power	90VA

1.5 Define Working Principle

1.5.1 P3210L High Pressure Constant Pump

The P3210L high pressure constant pump in the EClassical P3200L series of high pressure constant pumps is an integrated installation of one one-element high pressure constant pumps in a set of equipment, such as Figure 1-1. The solvent is sent to the degasser through the inlet, and then sent to the pump head cavity. Due to the sealing effect of the inlet and outlet check valves, the maximum pressure of 90 MPa can be generated in the cavity. Next the solvent is sent to the pressure transmitter, and the pump pressure is collected at the pressure transmitter. The outlet of the pressure transmitter is connected to the pulsation damper, and the pulsation damper is connected to the vent valve. Flushing needs to open the vent valve to allow the pump system to drain through the bypass. Closing the vent valve, the solvent flows through an on-line filter and is transmitted after filtering.

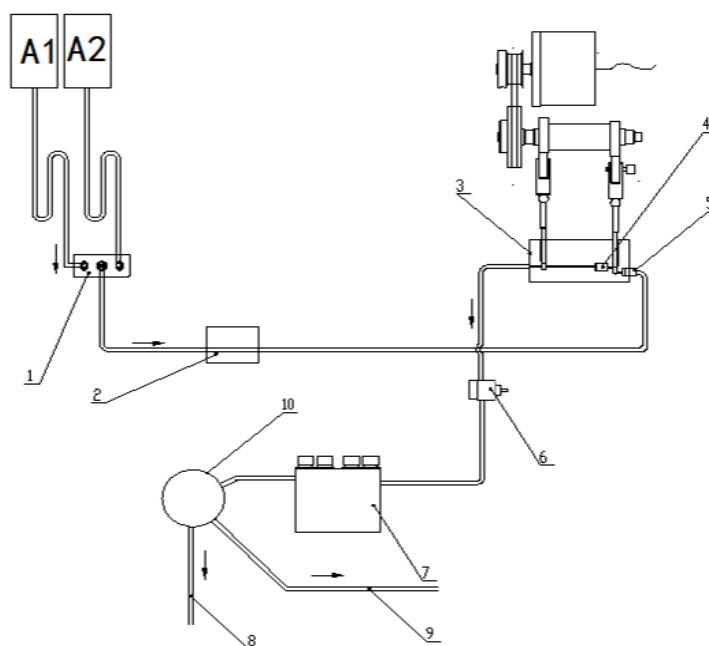

Figure 1-1 Working principle

- 1.Solenoid switching valve;2.Degasser;3. Pump head;4. Inlet check valve;
5. Outlet check valve;6. Pressure sensor;7. Pulsation damper
Mixer;8. Solvent excit;9. Outlet;10. Relief valve;

1.5.2 P3220L/P3202L High Pressure Constant Pump

The P3220L/P3202L high pressure constant pump in the EClassical P3200L series of high pressure constant pumps is an integrated installation of two one-element high pressure constant pumps in a set of equipment, each pump appears as a channel, and the binary gradient is generated after high-pressure mixing, such as Figure 1-1. Taking the A channel as an example, the solvents A1 and A2 are sent to the degasser through the inlet selector valve, and then sent to the pump head cavity. Due to the sealing effect of the inlet and outlet check valves, the maximum pressure of 90/70 MPa can be generated in the cavity. The solvent discharged from the double pump head cavity is merged through the outlet tee, and the B channel is exactly the same as the A channel. After the solvent merges, the pressure transmitter is sent, and the pump pressure is collected at the pressure transmitter. The outlet of the pressure transmitter is connected to the mixer, the mixer is connected to the pulsation damper, and the pulsation damper is connected to the vent valve. Flushing needs to open the vent valve to allow the pump system to drain through the bypass. Closing the vent valve, the solvent flows through an on-line filter and is transmitted after filtering.

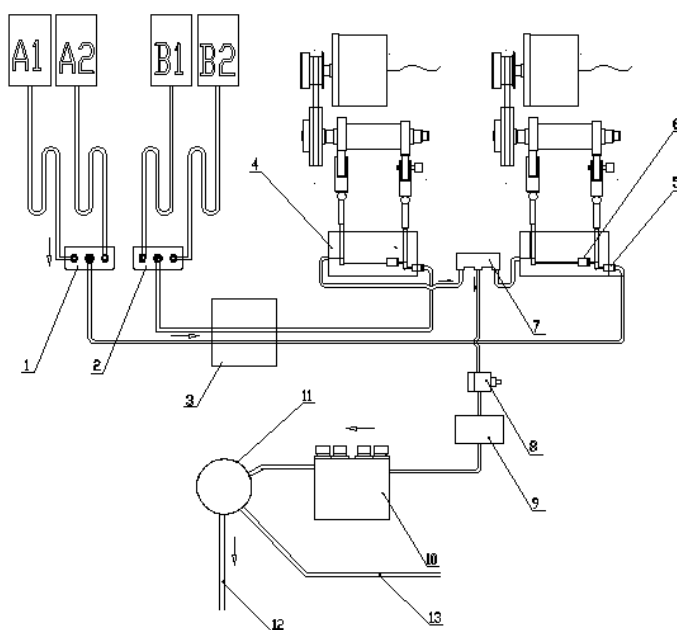

Figure 1-2 Working principle

- 1.Solenoid switching valve;2. Solenoid switching valve;3. Degasser;4. Pump head;
5. Inlet check valve;6. Outlet check valve;7. Tee connector;8. Pressure sensor;9. Mixer;
10. Pulsation damper;11. Relief valve;12. Solvent exit;13. Outlet

1.5.3 P3230L/P3203L Quaternary Low Pressure Constant Pump

The P3230L/P3203L quaternary low pressure constant pump in the EClassical P3200 series of high pressure constant pumps uses a high pressure constant pump with a proportional valve to mix the four mobile phases at low pressure at the inlet, such as Figure 1-2. Taking the A channel as an example, the solvent A enters the degasser through the A inlet. The solvent ratio of the four channels is controlled by a solenoid valve. Each solvent channel is opened according to a preset ratio, and is collected and mixed at the outlet of the solenoid valve, and then enters the high pressure constant pump. By sealing one-way valve, the pump maximum pressure resistance of 63 MPa. The solvent is converged at the three links of the pump and delivered to the pressure transmitter, where the pressure is collected. From the pressure transmitter to the mixer, and then from the mixer to the vent valve. Flushing needs to open the vent valve to allow the pump system to drain through the bypass. When the vent valve is closed, the solvent flows through the on-line filter and is discharged after being filtered.

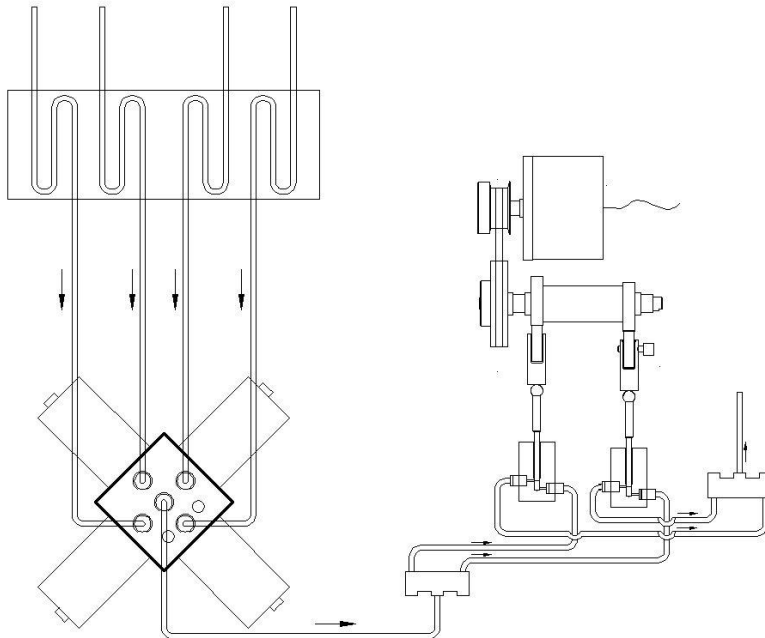

Figure 1-3 Working principle

1.6 Appearance of the instrument

All models EClassical P3200L series of high pressure constant pump have the same appearance of the instrument shown in Figure 1-3.

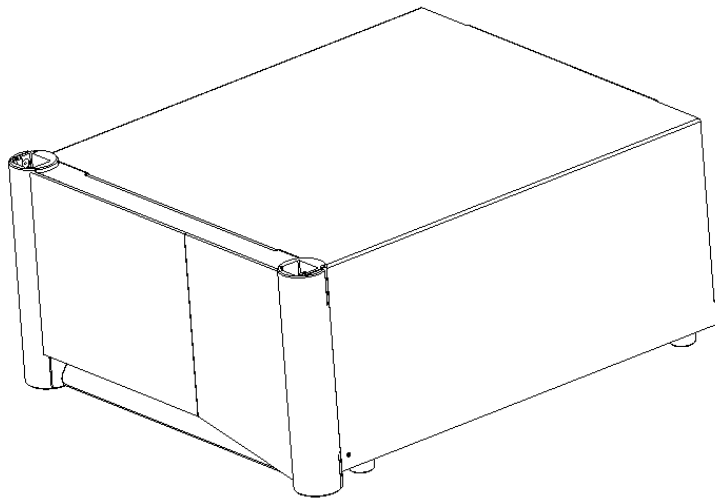

Figure 1-4 Three-dimensional FIG

1.7 Instrument structure and layout

1.7.1 EClassical P3200L Front

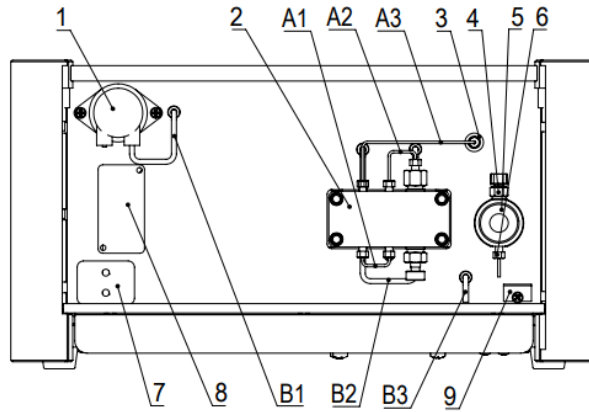

Figure 1-5 Front panel of P3210L

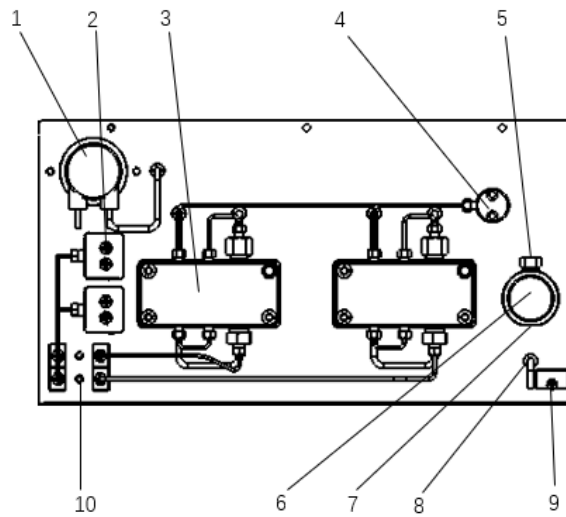

Figure 1-6 Front panel of P3220L/P3202L

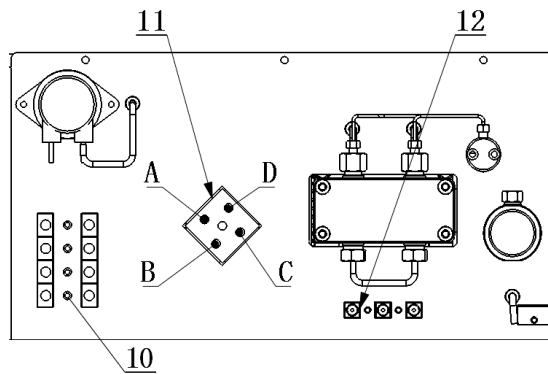

Figure 1-7 Front panel of P3230L/P3203L

Table 1-7 Front panel of EClassical P3200L introduction

No.	Components	Function
1	Peristaltic pump	Transporting washing liquid
2	Pump head	To draw and deliver mobile phase
3	SS Union	Tube connection
4	Outlet of the pump	Mobile phase come out from here
5	Relief valve	Loosen the relief valve knob to release pressure from the pump head. It can be used for purging and priming purpose.
6	Relief tube	release air and waste liquid from the pump head
7	Degasser cover	Occlude reserved space
8	Select valve cover	Occlude reserved space
9	Leak alarm	Pump leak alarm
10	Tee	Fluid confluence
11	Degasser	Degassing the mobile phase
12	Select valve	Select channel
13	Four column select valve	Control the proportion of four channels of mobile phase
14	Tee	Liquid enters the pump

Table 1-8: Front panel of EClassical P3200L flow tube

No.	Components	Function
A1	Tube above the pump head	Main and auxiliary pump heads in series
A2	Tube under the pump head	Main and auxiliary pump heads in series
A3	A pump head to tee tube	A pump head and outlet tee connecting tube
A4	B pump head to tee tube	B pump head and outlet tee connecting tube
A5	Solenoid valve A to degasser tube	Solenoid valve A and degasser connecting tube
A6	Solenoid valve B to degasser tube	Solenoid valve B and degasser connecting tube
A7	Degasser to A pump head tube	The degasser and A pump head connecting tube
A8	Degasser to B pump head tube	The degasser and B pump head connecting tube
A9	Degasser to four column select valve tube	The degasser and Four column select valve connecting tube
A10	Four column select valve to tee tube	Four column select valve and tee connecting tube
A11	Tee to pump head tube	Tee and pump head connecting tube

Table 1-9: Front panel of EClassical P3200L cleaning tube

No.	Components	Function
B1	Peristaltic pump Outlet	Washing waste liquid discharge
B2	Pump head cleaning pipe	Main and auxiliary pump head plunger series cleaning
B3	Cleaning fluid outlet pipe	Plunger cleaning fluid discharge

1.7.2 EClassical P3200L Rear

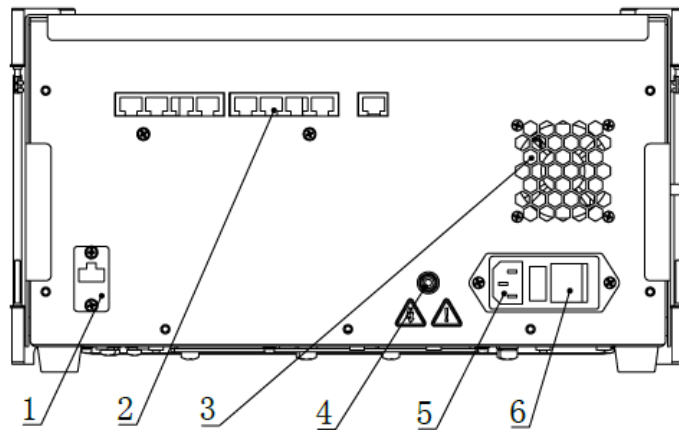

Figure 1-8 Pump rear panel

Table 1-10: Rear panel

No.	Components	Function
1	Communication interface	The communication interface between the instrument and workstation.
2	Communication interface	The communication interface between the instrument.
3	Cooling fan vent	Cool the instrument.
4	Ground terminal	Ground the main body of the pump.
5	Power connector	The power cable is connected into grounded power outlet.
6	Power switch	Turn on / turn off the power.

1.7.3 Internal introduction of P3210L

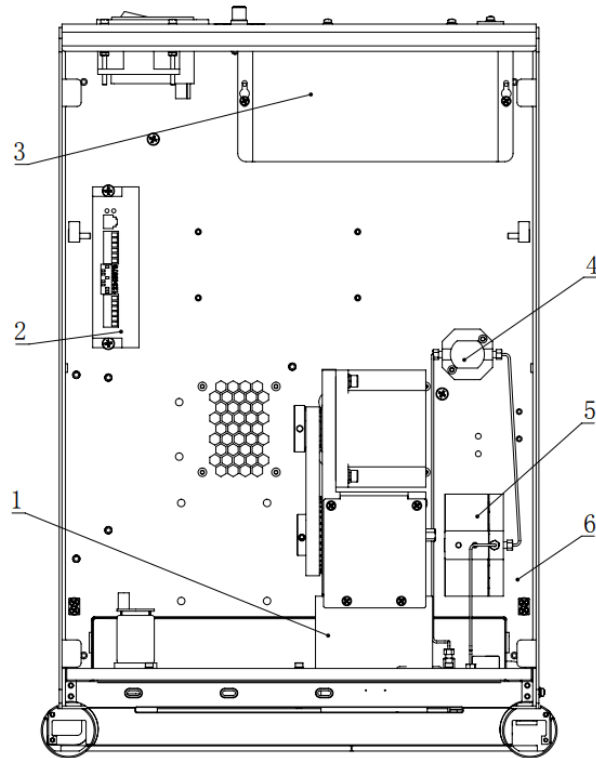

Figure 1-9 Internal introduction of P3210L

- 1.Pump;2. Motor driver;3. Communication interface;
- 4. Pressure sensor;5. Pulsation damper;6. Bottom plate

1.7.4 Internal introduction of P3220L/P3202L

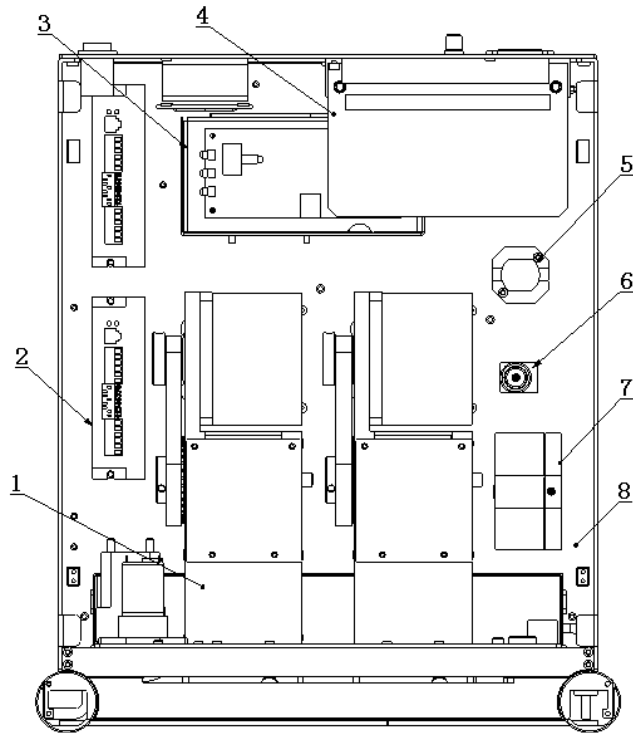

Figure 1-10 Internal introduction of P3220L/P3202L

1.Pump;2. Motor driver;3. Degasser;4. Communication interface;
5. Pressure sensor;6. Mixer;7. Pulsation damper;8. Bottom plate

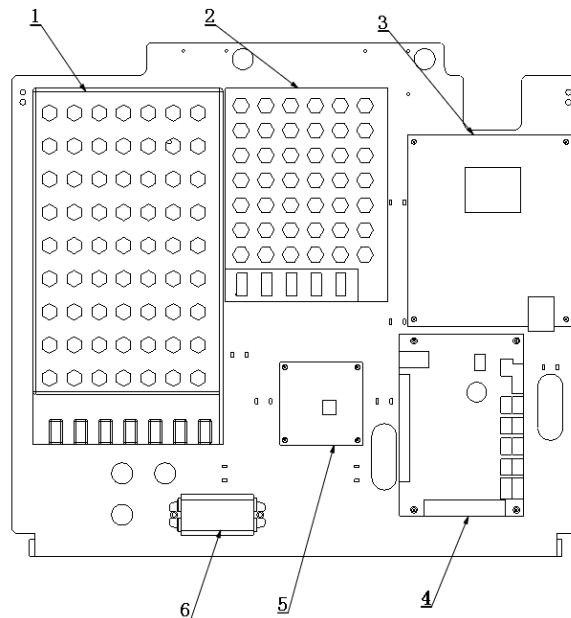

Figure 1-8 Internal introduction of P3220

1.48V Power switch;2.24V/5V Power switch;3. Motherboard;4. Control circuit board;
5. Leakage alarm circuit board;6.9V Power module;

1.7.5 Internal introduction of P3230L/P3203L

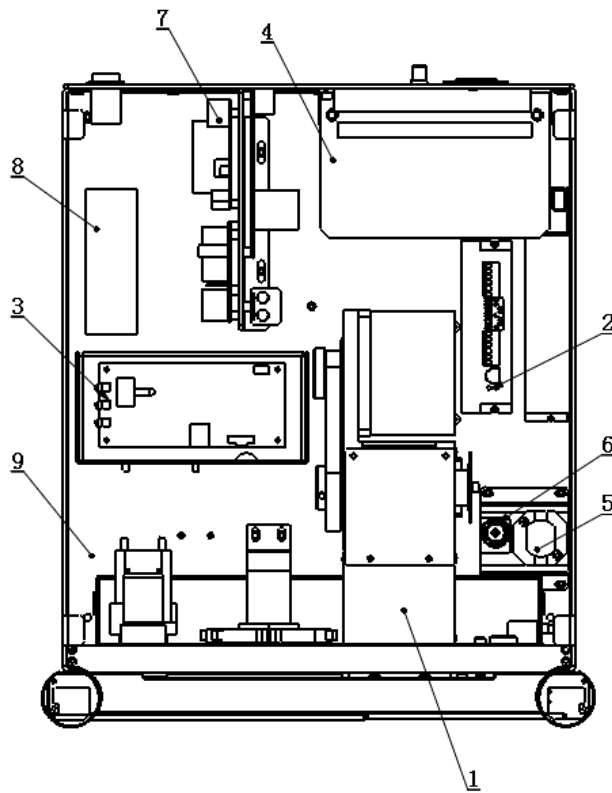

Figure 1-9 Internal introduction of P3230L/P3203L

1.Pump;2. Motor driver;3. Degasser;4. Communication interface;
5. Pressure sensor;6. Mixer;7. Pulsation damper;8.Power switch;9. Bottom plate

2. Installation and transportation

2.1 Unpacking acceptance

Upon receipt of the instrument, the instrument first check the packaging is intact without damage, if found signs of damage to the packaging, please contact me or your local dealer.



【Caution】

If the instrument you received shows signs of damage, please do not try to install and debug the instrument. You can ask our company to inspect and evaluate the condition of the instrument.

2.1.1 Unpacking

Place the box face up on a level ground. Cut off the top tape and take out the instrument and accessory box with the inner packaging. Sequentially removing the foamed material, open the protective film.◦



【Caution】

There are two or more people working together in the process of disassembly and installation. Preventing the instrument from accidentally slipping and causing damage to the instrument or personal injury!

2.2 Stack Order

In order to guarantee the best working state of the instrument, it is recommended that the instruments should be stacked as shown in Figure 2-1.

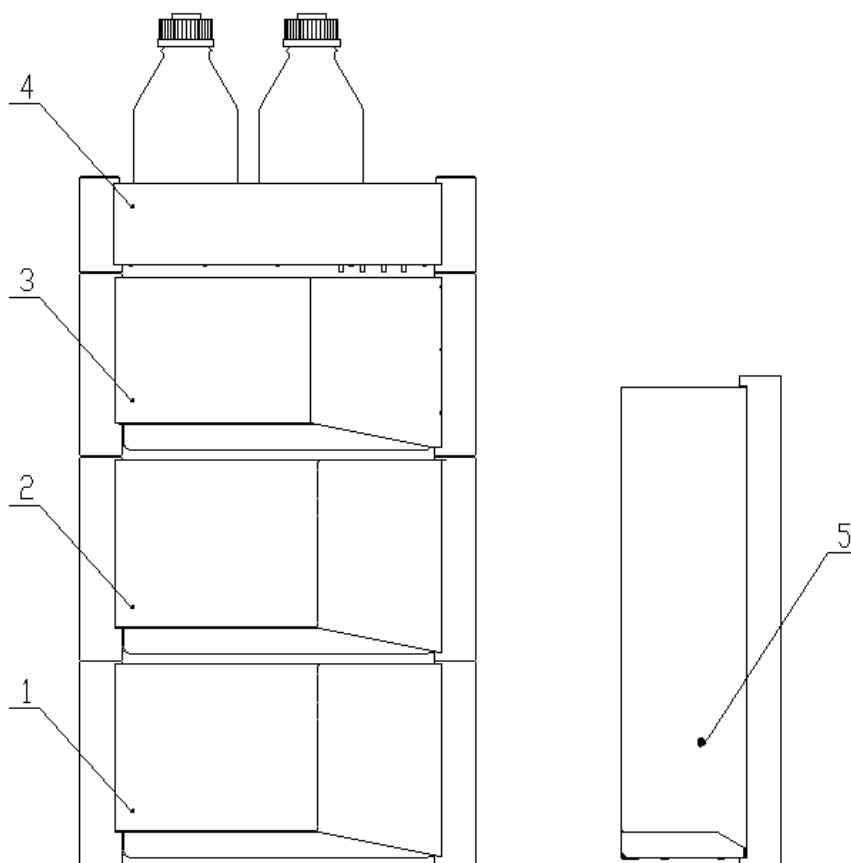

Figure 2-1 EClassical 3200L stack order

1.Pump;2. Auto-sampler;3. UV-vis detector;4. Solvent bottle tray;5. Column oven

2.3 Installation Requirements

2.3.1 Site Requirements

Environment

EClassical P3200L series of high pressure constant pump need to work under ambient conditions in Table 2-1 below:

Table 2-1: Environment requirements

Items	Specifications	Requirements
1	Work environment	Room should be free of dust, inflammable and explosive materials, also, good ventilation is important
2	Electromagnetic field	No electromagnetic noise nearby
3	Operating temperature	4~40°C(39~104°F)
4	Humidity	20%~80%, non-condensing
5	Temperature fluctuation	< ± 2°C /hr



【Caution】

Do not use the pump under the conditions of temperature fluctuations. If the ambient temperature is too low, make the room temperature increase slowly to avoid condensation inside caused by rapid heating.

Bench space

EClassical P3200L series of high pressure constant pump's dimensions allow placing the pump on almost any laboratory bench. If you want to display EClassical 3200L on the bench, make sure that the table can bear the weight of all components. It needs an additional 50mm on the left, 150mm on the right, 150mm on the back to facilitate the circulation of air and electrical connections.



【Warning】

The instruments should be placed on a horizontal position, otherwise there is a risk of falling!

Power and power line

To ensure the instrument can be normal and safe, please use a dedicated power line within the specified voltage range.

Grounding, AC power to 220V \pm 10%, 50 Hz;

High pressure, please choose T2AL250V fuse.



【Warning】

The accessory power cable should be used to connect the pump with the power socket. Other cable should not be used in case of danger or damage to the instrument.

If the instrument is connected to a grid above the scope of application, it may cause electrical shock or damage to the equipment and staff.

Please unplug the power cord before replacing the fuse to avoid electric shock. The external fuse is installed in the back of instrument.

Computer requirements

Hardware requirements

- The lowest hardware requirement: Intel Core 2 CPU, 2G internal storage, more than 1G hard-disk space;(Refer to the manual of workstation)
- The lowest resolution of displayer: 1024×800,64K (16 bit image);
- Others: USB interface for communication, CD-ROM driver for software installation.

Operation system requirements

- Windows 7 or higher version(Refer to the manual of workstation).

Workstation requirements

- Use KROMSTATION workstation or Kromstation to control the instruments.

2.4 Circuit and communication connection

The circuit and communication line of EClassical 3200L are shown in Figure 2-2.

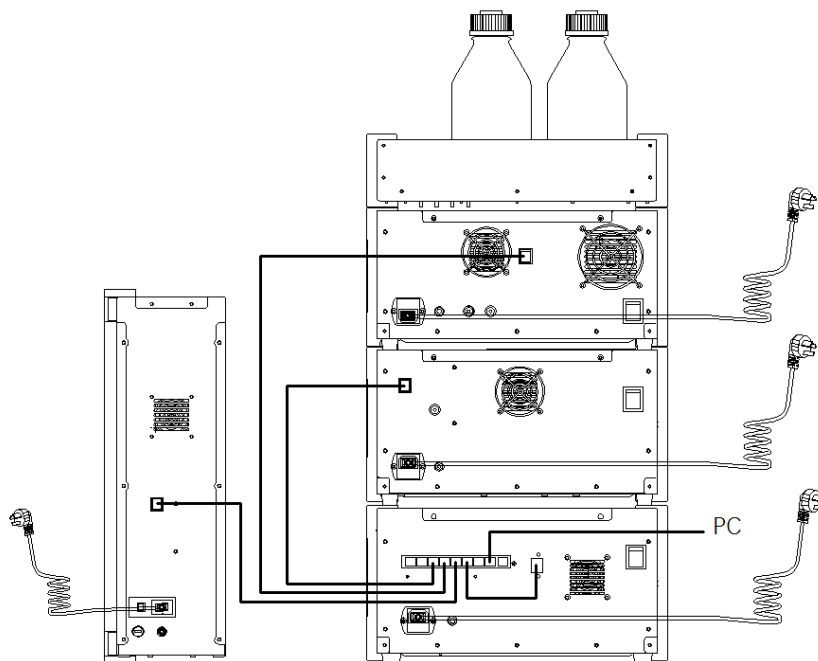

Figure 2-2 EClassical 3200L circuit and communication connection

2.4.1 Circuit connection

EClassical P3200L series of high pressure constant pump constant follow these steps:

- 1) Place the pump in the HPLC system according to the stack order.
- 2) Make sure the power switch on the rear panel of the pump is OFF.
- 3) Connect the pump to the power supply.



【Caution】

The power switch is off, and the instrument is still live. To disconnect the power completely, please unplug the power cord on the rear panel of the instrument!

2.4.2 Communication connection

EClassical P3200L series of high pressure constant pump constant follow these steps:

- 1) Make sure the power switch on the rear panel of the pump is OFF.
- 2) Connect the computer and the yellow network port of the pump with a network cable.
- 3) Connect the yellow network port of the pump to the black network port of the pump with a network cable.

2.5 Fluid Connection System

Solvent tube system diagram of EClassical 3200L are shown in Figure 2-3.

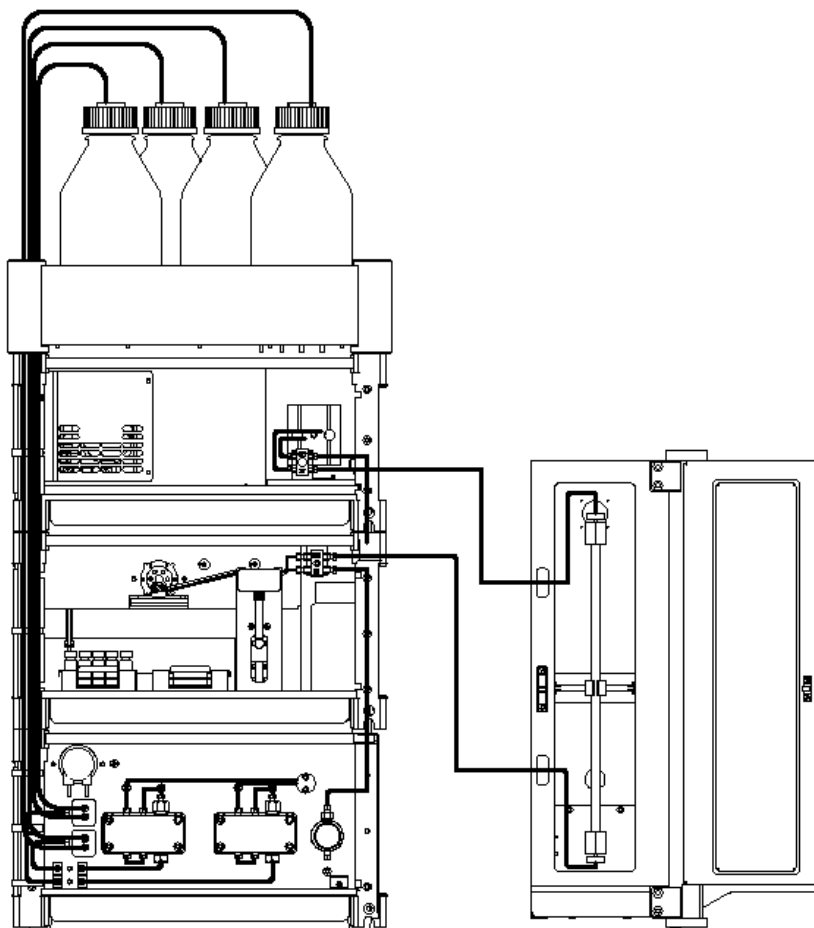

Figure 2-3 Fluid connection diagram

2.5.1 Tube use

- *Pipe cutting*

Please use a special pipe cutter to make the cutting surface level.



【Caution】

The cutting surface should be flat to avoid dead volume and inner diameter deformation.

- *Connect the metal sealing ring*

The correct way of connecting screws and metal sealing rings for stainless steel pipes is shown in Figure 2-4 and 2-5.



【Caution】

Please use matching screws and sealing rings.

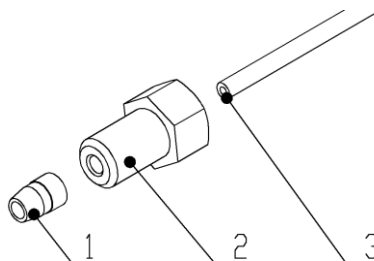

Figure 2-4 Connection diagram

1. Metal sealing rings; 2. Connecting screws; 3. Stainless steel pipe

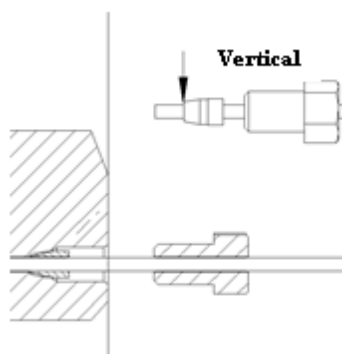

Figure 2-5 Seal ring and tube

2.5.2 Flow connection

1) Connection of solvent filter suite and infusion tube

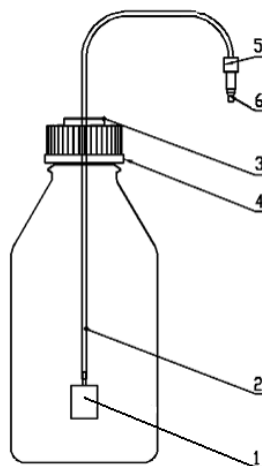

Figure 2-6 Solvent filter suite and infusion tube

- 1.Solvent filtration;2.Infusion tube;3.PTFE plug;4.Bottle cap;
5.1/8"Solenoid valve connecting nut;6.1/8"Omni-Lok Solenoid valve connecting
Ferrule

2) *Connection of solvent bottle and pump*

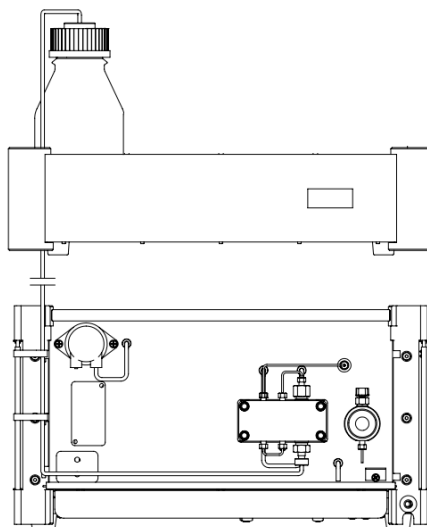

Figure 2-7 Connection of solvent bottle and pump (P3210L)

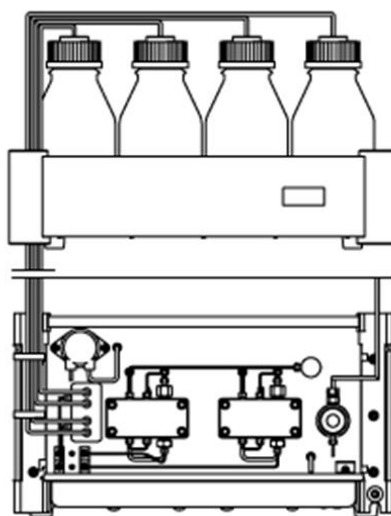

Figure 2-8 Connection of solvent bottle and pump (P3220L)

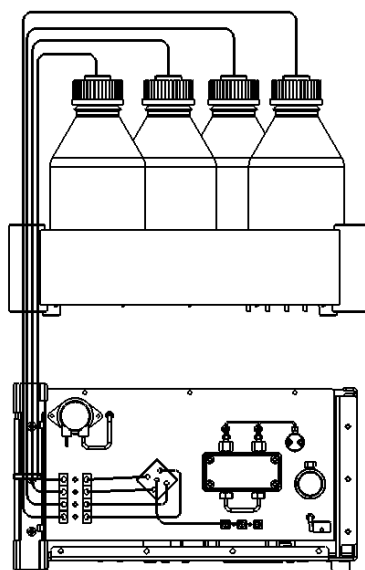

Figure 2-9 Connection of solvent bottle and pump (P3230L)



【Note】

- ◆ The Solvent filtration needs to be cleaned frequently to prevent contamination.
- ◆ The liquid in the dissolving bottle must be degassed.
- ◆ The solvent must be filtered through a membrane with a pore size of 0.45 μ m or less.

3) *Pump and autosampler connection*

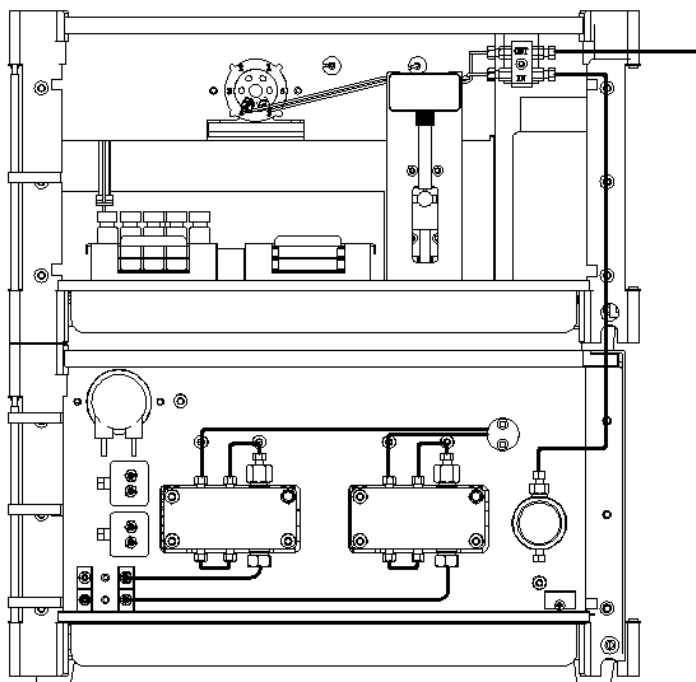

Figure 2-10 Connection of pump and autosampler

4) *Connection of autosampler and chromatographic column*

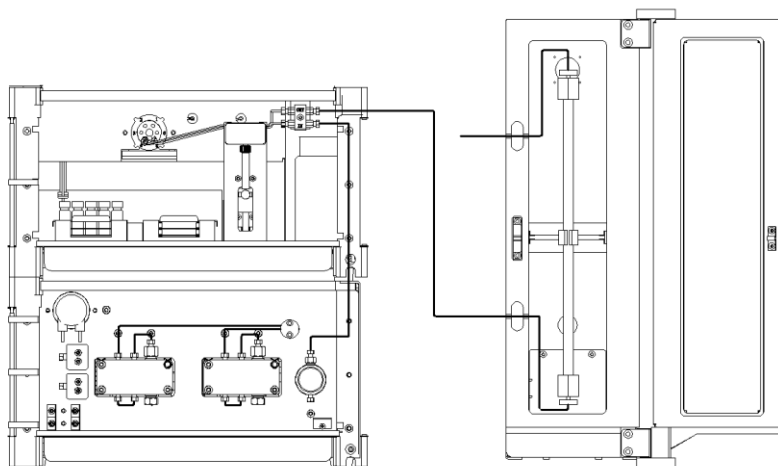

Figure 2-11 Connection of autosampler and column

5) *Column and detector connection*

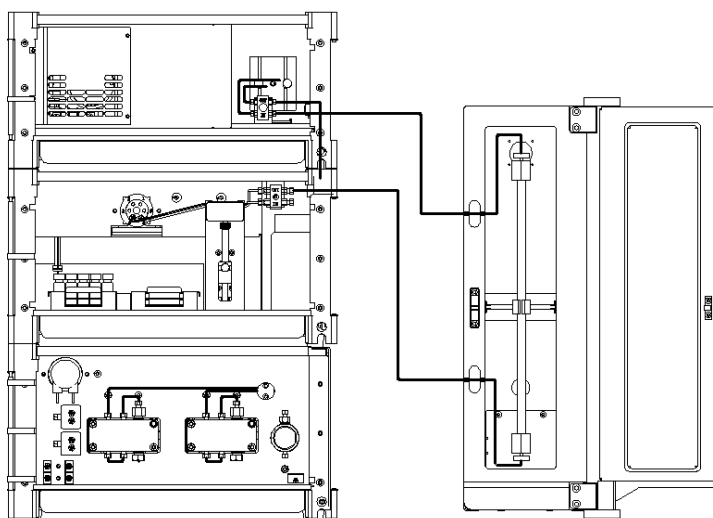

Figure 2-12 Connection of Column and detector

6) *Pump head cleaning connection*

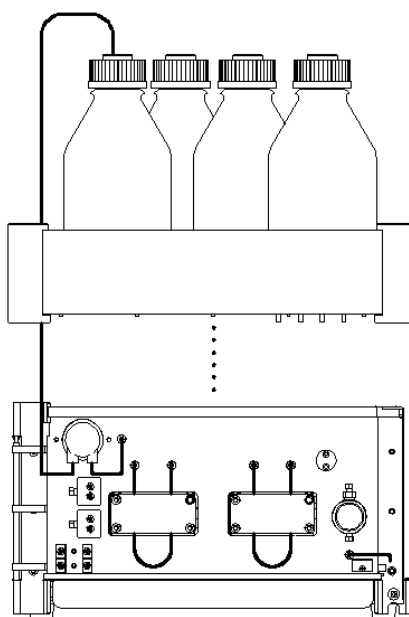

Figure 2-13 Connection of pump head cleaning



【Note】

The solvent waste bottle should be place at a lower position with respect to the equipment.

2.6 Preparation for use

The new pump must be filled with liquid. If the system is a positive phase, as a filling liquid recommended to use isopropanol. If the system is reversed phase, it is recommended to use methanol as the filling solvent. The specific operations are as follows:

- 1) Open the Relief valve.
- 2) Set the A channel ratio to 100% and the flow rate to 8.000mL/min.
- 3) If the solvent does not flow out of the channel A, available Pipette or syringe pump at the discharge port until the liquid flows.
- 4) Approximately 30ml of liquid flows out of the pump outlet to eliminate remaining air bubbles.
- 5) Close the Relief valve.
- 6) The solvent switch to another channel and repeat steps 1-5.



【Note】

When the line connection process, the solvent may flow out from the tube joint. Toxic and harmful reagents may be harmful to health, please take protective measures.

2.7 Verification

In normal instance, the instrument customers received have been tested and came with verification. the performance met our requirements in factory. Users have no need to test and verify. If you have any doubt about the performance of the pump, verify it refer to the following steps:

2.7.1 Check the sealing performance

- 1) Connect the chromatographic column properly, then, start the pump and observe whether the pressure displayed is stable. If not, please clean check valve or relief bubble in pump head.
- 2) Set the max alarm pressure to 81MPa. Close the outlet of the injection valve.
- 3) When start the pump, the pressure will raise slowly. When the pressure reaches 81MPa, the pump will stop automatically. Observe the pressure drop on the screen.
- 4) Pressure drops less than 1.5MPa in 10min, sealing of the pump is qualified.
- 5) Pressure drops more than 1.5MPa in 10min, many factors should be considered, such as seals lax of check valve, sampling valve or piping joint, or air bubbles in the pump head.

Isocratic system

- 1) Take a chromatographic column. For the positive phase system SiO₂ column can be selected, while C18 column can be used for inverse system.
- 2) Prepare mobile phase and samples according to evaluation report provided by the column manufacturer.
- 3) Empty air bubbles in the pump system. When the system is stable, detect the signal according to the testing requirement.
- 4) If the result and column efficiency is confirmed to the information provide by column manufacturer within the error range, that means the HPLC is qualified.

Gradient system

1) Connect gradient system to the detector through a two-way union. Set the detected wavelength to 254nm.

2) Link the workstation to gradient system and detector, set gradient parameters according to Table 2-1. Mobile phase A is pure water, mobile phase B is 0.2% (V/V) acetone water and the total flow rate is 1.0 mL/min.

Table 2-1: Gradient parameters

Time (min)	A (%)	B (%)	Rate (mL/min)
0.00	100.0	0	1.0
2.00	100.0	0	1.0
2.01	80.0	20.0	1.0
7.00	80.0	20.0	1.0
7.01	60.0	40.0	1.0
12.00	60.0	40.0	1.0
12.01	40.0	60.0	1.0
17.00	40.0	60.0	1.0
17.01	20.0	80.0	1.0
22.00	20.0	80.0	1.0
22.01	0.0	100.0	1.0
27.00	0.0	100.0	1.0
27.01	100.0	0.0	1.0

3) Start to collect data until the instrument is stable. Gradient error was calculated by the formula (2-1). Take the largest for gradient accuracy.4) If each step is smooth without obvious concave and convex and mixed gradient accuracy is within $\pm 2.0\%$, the gradient confirms to the requirements and the two pumps match well.

$$T_{Ci} = L_{ti} - \frac{V_i - V_A}{V_A - V_B} \times 100\% \tag{2-1}$$

T_{Ci} ——The i segment gradient error

L_{ti} ——Set gradient value of the ith segment

V_i ——The signal value of the ith segment

V_A ——The signal value when the mobile phase A is 100%

V_B ——The signal value when the mobile phase B is 100%

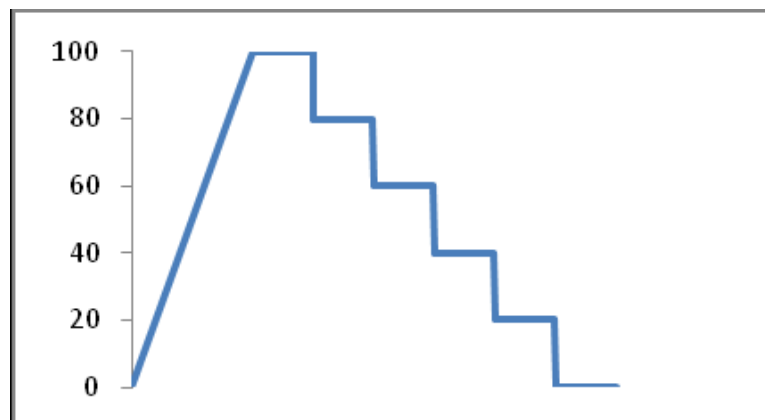

Figure2-15 Gradient diagram

2.8 Transportation

High pressure constant flow pump is a precision instrument, please be careful while long-distance transportation. Severe vibration and drops are likely to cause damage to the internal parts of the instrument. The original packaging can effectively protect the instrument. When the instrument is required to move or returned for service, please follow these steps for packaging.

- 1) Turn off the power.
- 2) Unplug the power cord.
- 3) Remove the connecting pipe and other elements between components.
- 4) Remove the pump from chromatography system. Put it into special sealed bag on a large platform.
- 5) Put the pump into the original packaging foam and fix it.
- 6) Place the fixed pump and other accessories into original packaging carefully.
- 7) Tape the box sealed to prevent liquid from entering. Covering the packaging box with plastic wrap is recommended.
- 8) Transport packaged instrument.



【Note】

Before packing, please check the box. If the original packaging has been damaged, do not use it. You should consult your local dealer or our company. customer service staff to solve!

Chapter Three: Basic Operation

3.1 Power On

Plug the power cord into the power outlet.

Boot Up: Turn on the power switch(“I” means power on, “O” means power off) and then the power indicator light will turn blue. The pump begins to self-test while the power indicator light is in the breathing state.

When the self-test passed, the power indicator light is on

Shut down: Turn off the power switch, then pump into hibernation.



【Warning】

Even if the power switch on the rear panel of the pump is turned off, the inside of the instrument is still live. To completely disconnect the power, unplug the power cord from the rear panel of the pump.

3.2 Kromstation workstation installation

Most of the functions of the pump need to rely on the control of Kromstation workstation to achieve. The structure diagram of Kromstation workstation is shown in Figure 3-1.

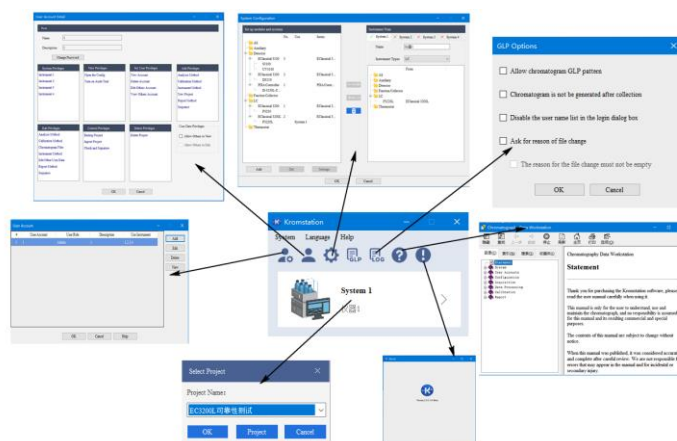

Figure 3-1 Structure diagram of Kromstation

3.3 Starting and stopping the pump

Kromstation workstation can control the pump in two ways. 1) Use "Set flow " and "Stop flow " in the device monitor window to achieve; 2) Control the pump through the "LC Gradient" in the "Method" interface of the main interface.

- In the "Device Monitor" window to achieve

Finding "Device Monitor", as shown in Figure 3-2.

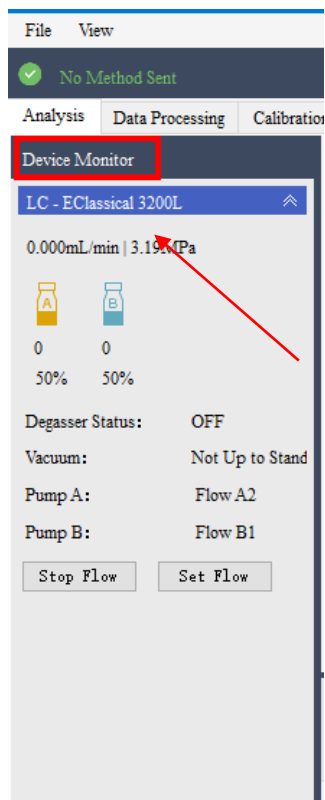

Figure 3-2 Clicking "Device Monitor"

The "Device Monitor" window is shown in Figure 3-3.

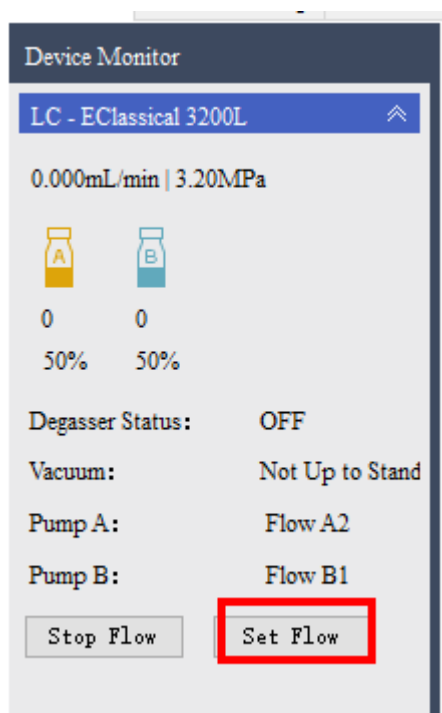

Figure 3-3 "Device Monitor"

In the device monitor window, clicking "Set flow ", entering the relevant values to control the pump, as shown in Figure 3-4.

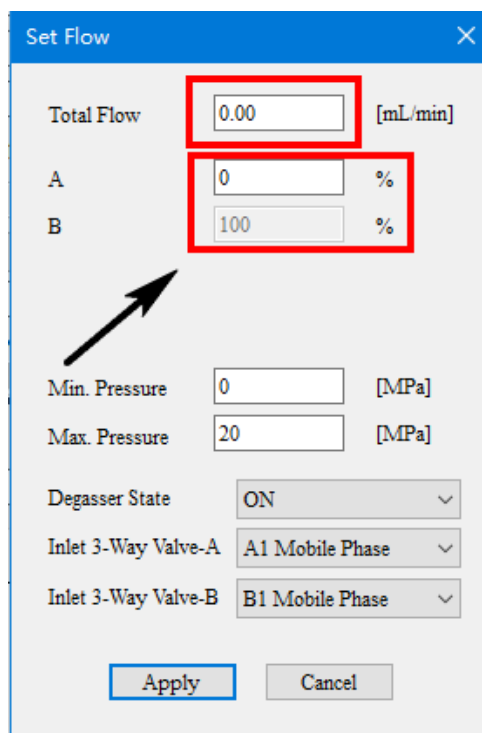

Figure 3-4 "Set flow "

● In the "Method" window to achieve

In the "Single" window, select " Inst.Method " as shown in Figure 3-5. By setting the mobile phase conditions, control the pump's operating status as shown in Figure 3-6.

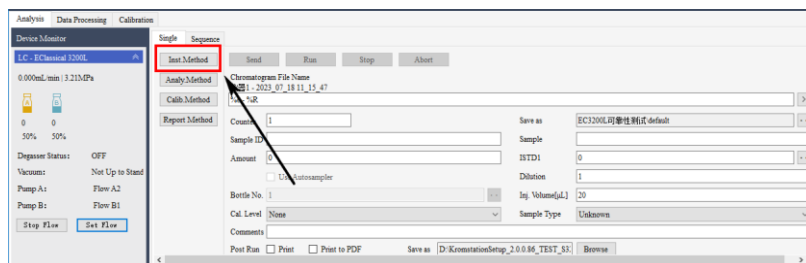

Figure 3-5 Enter the " Inst.Method"

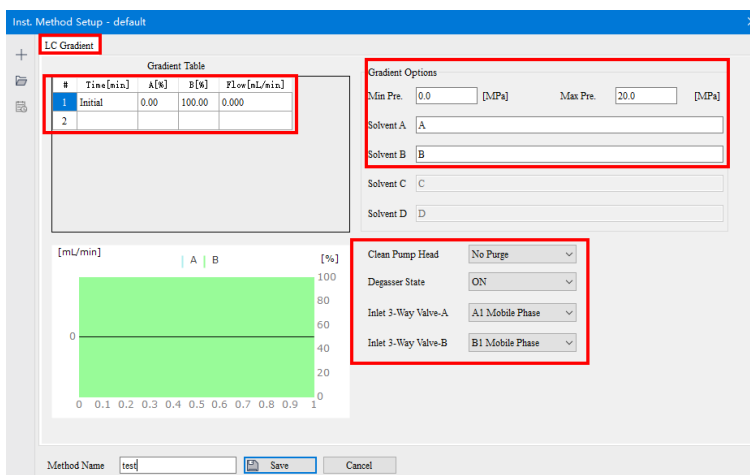

Figure 3-6 Enter the " LC Gradient "

3.4 Units setting

Open the “System” as shown in Figure 3-7.

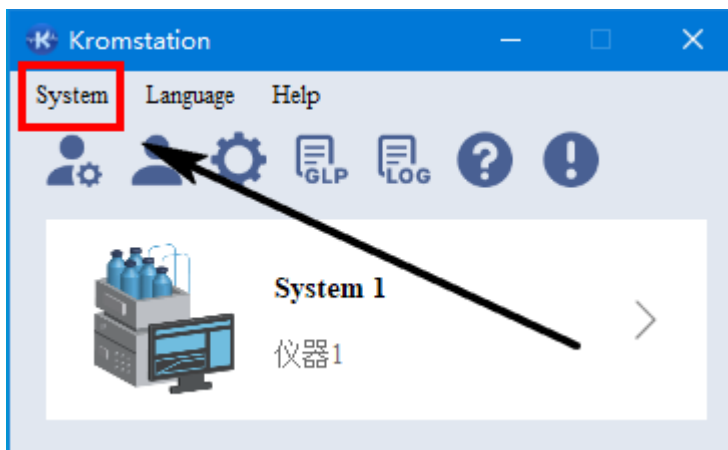

Figure 3-7 Enter the “System”

Click the icon "Unit Setup", as shown in Figures 3-8, to select the unit.

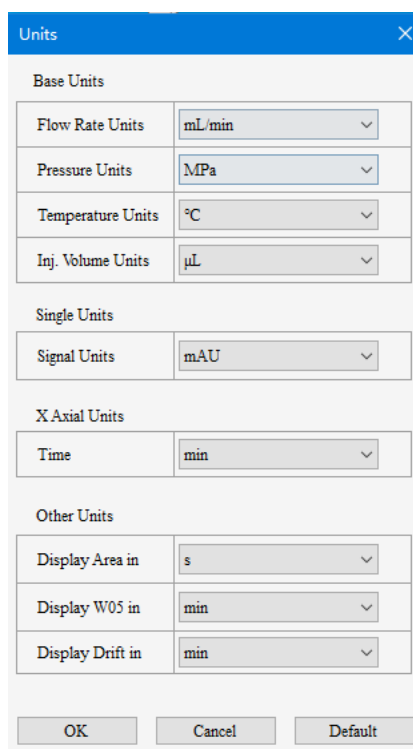

Figure 3-8 Selecting the units

3.5 Setting method flow rate

Setting the flow rate in the " LC Gradient " window

- **Setting method flow rate**

In the " LC Gradient ", can set the time, A, B (C, D) channel solvent percentage and flow rate. Percentage of solvent channel may be modified within the range of 0 to 100, after setting the percentage of channel A, the percentage of B (D) channels of the mobile phase is automatically generated software. The total flow rate of the respective flow channels, can be 0.000 ~ 10.000mL / min, as shown in Figure 3-9.

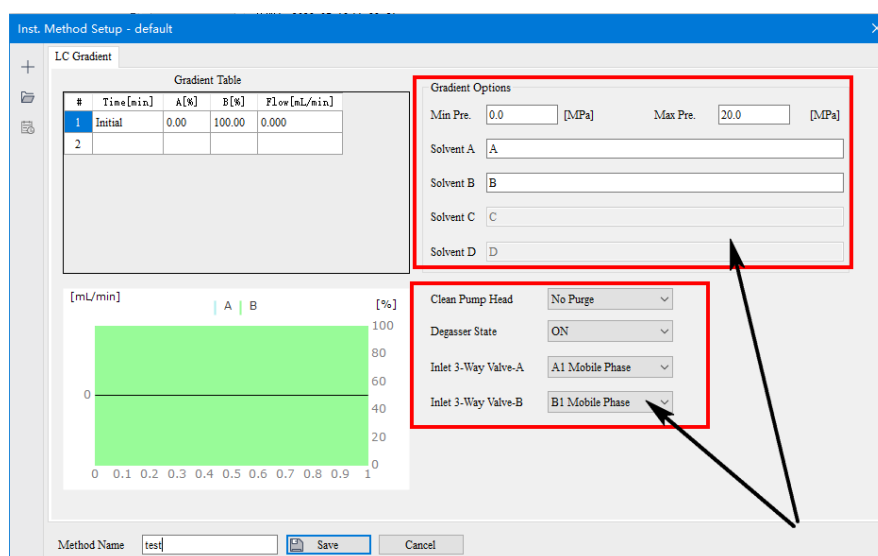

Figure 3-9 Setting the " LC Gradient "

There are four options for the idle state in the " LC Gradient ", which are "Pump off" , "Initial", "Standby", and "Initial-standby".

" Pump off " means that the system automatically turns off the pump after the analysis is completed.

" Initial " means that after the analysis is completed, the pump runs in the initial state of the method.

"Standby" means that the pump is in the standby state after the analysis is completed.

"Initial-Standby" means that after the analysis is completed, the instrument first enters the initial state, and then into the standby state.



【Note】

- ◆ The minimum time unit is 0.01 min, and the minimum unit of volumn percentage is 0.1%, as well as the minimum flow rate unit is 0.001mL/min.
- ◆ Idle state means the pump state without running methods.

3.6 Setting system pressure and solvent number

In the “Gradient Options”, setting the system maximum and minimum pressure and solvent number, as shown in Figure 3-10. When the pressure exceeds the set value, the system will automatically alarm.

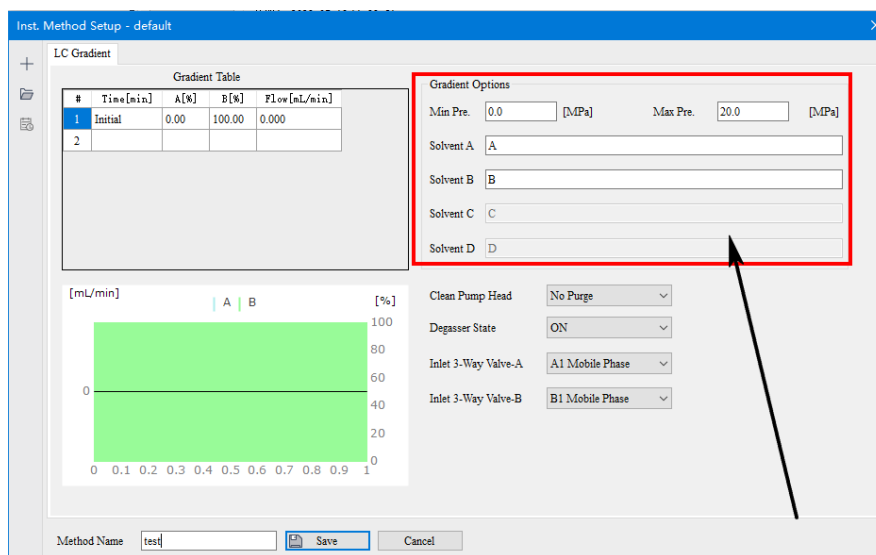

Figure 3-10 Setting “Gradient Options”

3.7 Mobile phase replacement

There are various liquids used in HPLC as mobile phase, including organic solvents, water, buffers, etc. Miscibility and buffer salt precipitation are important issues that should be considered. Please take care when you need to replace mobile phase. If necessary, you can refer to the corresponding physical chemistry handbook.

3.7.1 Replacing with miscible liquid

E.g. replacing methanol with acetonitrile

- 1) Store acetonitrile in a clean solvent bottle.
- 2) Take the filter components out from methanol reservoir, wash it with acetonitrile, then, put it into acetonitrile.
- 3) Open the relieve valve. Flush the pump with approximately 20mL of the new mobile phase.
- 4) Close the relieve valve, disconnect the column from the system, then, put a bottle at the outlet of the inject valve.
- 5) Turn on the pump and pump the new mobile phase out about 10 mL.
- 6) Reconnect the column. Turn on the pump at a suitable flow rate, e.g. 1mL/min. The system needs to equilibrate for at least 30 minutes.

3.7.2 Replacing with immiscible liquid

E.g. replacing methanol with n-hexane

Choose an intermediate washing liquid, which must be miscible with both the new and old mobile phase. In the above example, iso-propanol can be used as the intermediate washing liquid, because iso-propanol is miscible with both methanol and n-hexane.

Follow the procedures as described in section 3.4.1 using the intermediate washing liquid to replace old one.

Repeat the procedures as described in section 3.4.1 using the new mobile phase to replace intermediate washing liquid.

3.7.3 Replacing organic solvent with salt buffer

Crystalline salt may appear when buffer salts mix with an organic solvent. Crystalline salt is harmful to the seals, the plunger rod, the injection valve and the internal rotor and stator, moreover, it may block the tube. So, please transition the system with a certain proportion of water-containing organic solvent before analysis. After the experiment is finished, do transition the system again with the same method above, and save the column with organic solvent.

Maintenance and Repair

4.1 LED status and significance

There is a bar-shaped LED light under the front panel of the pump. It is both a power indicator and a status indicator, as shown in Figure 4-1.

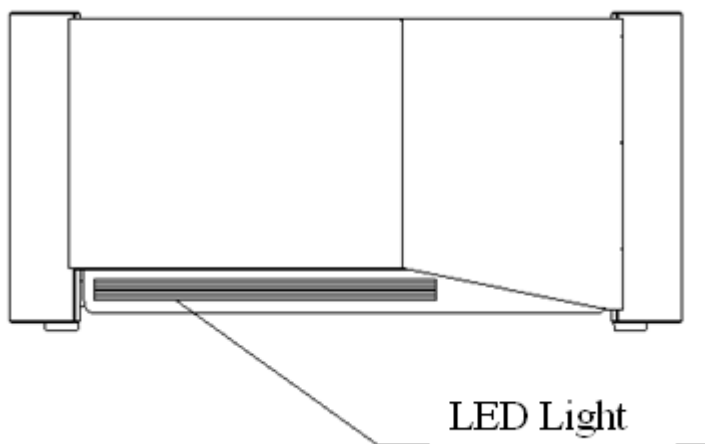

Figure 4-1 Bar-shaped LED light

Refer to Figure 4-2 for the specific LED status and significance.

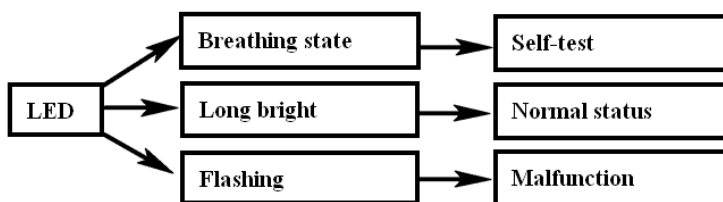

Figure 4-2 The specific LED status and significance

4.2 PC actual fault error code table

Table 4-1: PC error code and actual fault table

Error number	Error description	LED	Solutions
PB00	CPU system operational failure	Flashing	----
PB01	EEPROM failure	Flashing	----
PB02	8M crystal oscillator failure	Flashing	----
PB03	32M crystal oscillator failure	Flashing	----
PB04	Operational failure	Flashing	Stop pump inspection
PB05	Leakage	Flashing	Stop pump inspection
PS00	System CPU operation failure	Flashing	----
PS01	EEPROM failure	Flashing	----
PS02	8M crystal oscillator failure	Flashing	----
PS03	Pump pressure exceeds upper limit	Beeping	Reset pressure
PS04	Pump pressure exceeds the lower limit	Beeping	----
PS05	Pump shaft does not rotate	Flashing	----

4.3 Troubleshooting

Troubleshooting a pump can be frustrating and sometimes a mysterious process. This section outlines a common-sense process for troubleshooting a pump. If troubles cannot be solved when referring to this section, please contact our company post-sales service or local vendor.

4.3.1 Elimination of Air Bubbles

Air bubbles are likely to be trapped in P3100 pump under the following circumstances: the initial use of pump, the pump has been left idle for some time, improperly degassed mobile phase etc. It is crucial to eliminate these trapped air bubbles. Otherwise, they affect system operation in a number of ways, such as: pressure fluctuation, unstable flow rate, and damage the column.

How to eliminate trapped air bubbles

Open the relief valve and press “PURGE” key, flush with high flow rate to remove air bubbles in pump head and inlet lines.

If the pump is unable to draw mobile phase after “PURGE” key was pressed, use a syringe to withdraw mobile phase from outlet of relief valve until the liquid flow out.

If the pump is still unable to withdraw mobile phase, it is probably caused by the dirty check valve. Follow related content in maintenance manual to clean the check valve.

4.3.2 Leakage of pump head

Pump head leakage is a common problem. Seal damage in the pump head is the main cause of leakage. Therefore, when the pump discharge occurs, replace worn parts in time.

4.3.3 Overpressure

In the process of operation, real-time pressure monitoring system works. When the pressure exceeds the set maximum pressure, P3200L pump will automatically stop and alarm. Open the vent valve to release the system pressure is a good choice at this time. Then reset the pressure cap or

check the entire flow path to look for the reason of the surplus pressure.



【Caution】

Setting maximum pressure should be lower than the maximum pressure the column can withstand, or the column may be damaged.

4.3.4 Pump not delivering solvent

Pump not delivering solvent is usually caused by air bubbles in pump head or blocking in solvent filter. In general, the problem can be solved by eliminating air bubbles or cleaning solvent filtering cup. But a dirty check valve can also cause the problem. So, if the pump does not suck liquid after filtering and cleaning solvent cup, please clean the check valve. Cleaning check valve refers to the related contents in the user manual. Common failures and solutions are shown in table 4-2.

Table 4-1: A summary of most common problems affecting system operation

Symptoms	Cause	Solutions
Infusion instability and the pressure fluctuation	Bubbles in pump head	1.Eliminating air bubbles through the relieve valve. 2.Spare bubbles with a syringe through the relieve valve.
	The old solvent remained in the pump cavity	Increase the flow rate to replace old solvent from the relieve valve.
	bubbles in the solvent filter and the inter line	1.Vibration the solvent filter to eliminate air bubbles. 2.If the solvent filters are dirty, clean them with ultrasonic cleaner or replace solvent filters. 3. Degas the mobile phase.
	Something wrong with the check valves	Clean or change the check valve.
	Piston rod or seal leakage	1.Replace piston rod and seal. 2.Change the faulted part.
	Tube leakage	1.Tighten the screw where leakage occurs 2.Replace the failure parts.
	Tube jam	Clean or replace the tube.
Pump is running, but no liquid out	Air bubbles in the pump cavity	1.Eliminating air bubbles through the relieve valve. 2.Spare bubbles with a syringe through the relieve valve.
	Bubbles in the pump head entering from the infusion entrance	Tighten the cap of the pump head.
	Air in the pump head	Perfuse fluid in pump head, open the relieve valve and turn on the pump under the maximum flow rate until

Symptoms	Cause	Solutions
		there is no air bubbles appear.
	Incorrect check valve installation	Install the check valve correctly.
	Dirty check valve or worn check valve	Clean or exchange the check valve.
	No solvent in the reservoir	Fill up the reservoir.
The actual flow rate is lower than the set value	Abnormal check valve	Clean or exchange the check valve.
	Dirty filter	Clean or exchange the filter.
No liquid delivered by the pump (the pump is not running)	Power off	Turn on the power.
	The power supply is not connected	Connect power supply.
Flow rate decreases when the pump is running	Air in the pump is gathering	Open the relieve valve, let the pump run under high velocity to eliminate air bubbles.
	Solvent filters plugged	Open the cap of the pump head, if there is no liquid out from infusion tube quickly, it means solvent filter is plugged. Please clean or replace the filter.
	Immiscible solutions in the pump	Use transition solvent to dissolve Immiscible ones.
	Plunger seal leakage	Inspect and replace the piston rod and seal.
	Compression compensation failure	Check or replace the pressure board or pressure transmitter.
High pressure	Tubing blockage	Screening each section of pipe to find blocking part. Replace or cut off the block tube.
	Improper pipe diameter	Replace it with proper tube.
	Online filter blocking	Clean or replace filter sieve.
	Chromatographic column plugged	Replace the chromatographic column.
Flow rate is too high	The velocity compensation failure	Inspect or replace it (see instructions).
	P.C. board failure	Replace the P.C. board.
	Compression compensation failure	Inspect or replace it.
No/Low pressure	No solvent in reservoir	Fill up the reservoir.
	Vent valve is not tight	Tighten the relieve valve.
	Pump pressure sensor fault	Check or replace the pressure sensor.
	Pipe joint leakage	1.Tighten the screw or ferrule where is leaking. 2.Replace the worn parts.
	Seal leakage	Clean or replace the sealing ring.
	Both the inlet and outlet of the pump have air bubbles	Open the relieve valve and let the pump run under high velocity to eliminate air bubbles.
The pump has a humming sound and can not start properly	The motor failure	Stop the pump and check it.
	Phase voltage is too low	Phase voltage is too low.

Symptoms	Cause	Solutions
The pump stops in operation.	Pressure is higher than limit pressure	a) To reset the highest limit pressure. b) Replace the column. c) Replace tubes with proper ones.
	Power cut	a) Check the power supply. b) Shut off the main power supply, check the fuse.
Flow rate is zero	Air bubbles in pump head	Eliminate the air (refer to the above item).
	The entrance check valve plugged	Check and replace it.
	The export check valve plugged	Check and replace it.
	The direction of check valve is reverse	Install the check valve in the right direction.
The pump is on, the pressure is common, but no liquid comes out.	Serious leakage in the system	Repair injection valve or tube and fasteners between the pump and detector.
	Fluid passage blockage	Clean injection valve or the connection between the column and detector or particles in flow cell.
	The entrance of column is plugged with particles	Clean or replace the column inlet filter or replace the column. Degas mobile phase and samples properly.
The column pressure increases, but the flow rate decreases.	Column or protect column is partially blocked	Clean or replace the column inlet filter or replace the column.
	The entrance tube of the detector is partly plugged	Remove and clean the flow cell and line.

Maintenance and repair

In order to ensure the normal operation of the high pressure constant flow pump, maintenance and repair is important. Maintenance means simple repair. Such repairs can be done from the front panel of the pump. There is no need to take out the pump from the stacked configuration. And repair is mainly referred to those which need to change the internal parts and remove the pump body from the stacked configuration and disassemble.

5.1 Maintenance of solvent filters

Dirty reservoir and mobile phase contamination is likely to cause blockage to solvent filter. Also, using buffer for a long time may lead to filter pollution and flow impassability. The blockage, pollution and impassability will affect pump operation. Recommended practices can extend the service life of the filter and guarantee the normal work of the pump. Replacing colorless reservoir with brown reservoir is an effective way to prevent fungi biological from growing.

Filter all solvents through a 0.45 micron (or smaller) filter.

The aqueous mobile phase needs to be replaced or filtered often.

Under the allowed condition of test, add 0.0001 to 0.001 mole of sodium azide may put an end to the growth of fungi

When the solvent filter is blocked seriously, air bubbles will appear in infusion tube even if the mobile phase was degassed. Please clean the solvent filter at this time. Cleaning steps are as follows:

- 1) Remove the solvent filter from the bottle-head assembly and immerse it in a beaker with 30% nitric acid (v/v). Sonicate for 15 minutes.
- 2) Thoroughly rinse the solvent filter with distilled water. Sonicate the solvent filter in distilled water for 10 minutes.
- 3) Blow-dries the filter.
- 4) Sonicate the solvent filter again in distilled water for 10 minutes.
- 5) Blow-dries the filter again.
- 6) Reassemble the solvent filter and put it into mobile phase bottle.

5.2 Cleaning tube

Reading 2.6 Preparation for use.

5.3 Cleaning the check valve

Pump outlet and inlet are equipped with check valves. The components are the same, so a check valve component can be used for any end of the pump. The appearance of the check valve is shown in Figure 5-1.

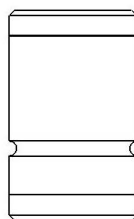

Figure 5-1 Appearance of the check valve

Usually, check valves have no need to clean. If sediment occurs in valve or valve ball and seat is adhesive, cleaning should be carried out.

Overall cleaning:

When the check valve has been assembled completely, overall cleaning can improve the adhesion condition.

- 1) Take out the check valve at the pump entrance: remove infusion tube from the entrance pressure cap, unload entrance pressure cap using a wrench and take the check valve components out.
- 2) Take out the check valve at the pump exit: remove infusion tube above pump head with a wrench, then, unload the pressure cap and take the component out.
- 3) Put them into ethanol and clean with ultrasonic twice in 15 min Then blow off the solvent inside.
- 4) Assemble the cleaned check valve properly while pay attention to the direction of the check valve.



【Warning】

The entrance of the check valve has ring mark nearby. If overall cleaning cannot solve the problem, deep cleaning becomes necessary. Cleaning steps are as follows:

Deep cleaning:

- 1) Unload the pressure cap with a wrench. Take the check valve out.
- 2) Make wallpaper knife into the gap between the coat and the gasket of the valve. Take the valve ball, seat and seal components out carefully. Put them into ethanol and clean with ultrasonic.
- 3) Observe the valve ball and seat with magnifying glass. If the valve ball or seat is damaged, please change a new one.
- 4) Assemble the cleaned check valve referring to figure 4-2. Roughness of different sides of the valve seat is not the same Identify them carefully before installation (the gem ball seats the smooth side).
- 5) Blowing is a good method to check the correction of the installation. Using a dust ball to blow the check valve from the inlet where have a ring mark nearby. You can feel airflow at the other side. Otherwise, air cannot pass through.



【Warning】

It is suggested using a small container during cleaning to avoid the loss of the valve components.

Each group of the valve ball and seat is grinded in pairs; therefore, the components cannot mix between different valves.

The system should be washed with methanol and deionized water successively if no one uses the pump for more than one month, or troubles may occur while the pump is running.

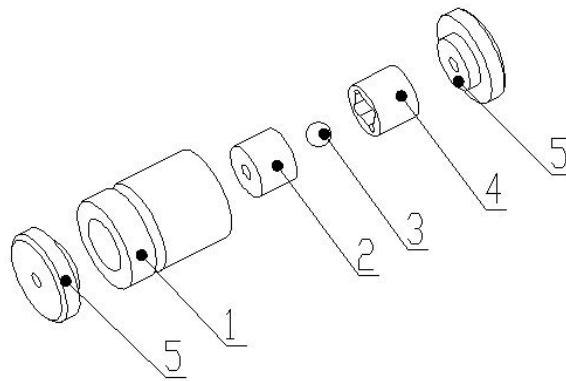

Figure 4-2: Assembly of the check valve

1. The marked valve jacket, 2. Valve seat, 3. Valve ball, 4. Seal with limit set, 5. Sealing gasket

5.4 Cleaning the online solvent filter

In order to prevent the particles in mobile phase coming into chromatographic system, the pump is installed an online filter in the vent valve to filter the mobile phase coming out from the pump outlet. It is recommended that users should clean the online filter in time. Use a wrench to unload the pressure cap, remove the sealing ring and the sintered stainless-steel filter, and then clean them. The specific steps are as follows:

- 1) Remove the filter disc. Immerse it in a beaker with 25% nitric acid (v/v). Sonicate for 15 minutes.
- 2) Thoroughly rinse the solvent filter with distilled water. Sonicate the solvent filter in distilled water for 10 minutes.
- 3) Blow-dries the filter.
- 4) Sonicate the solvent filter again in distilled water for 10 minutes.
- 5) Blow-dries the filter again.

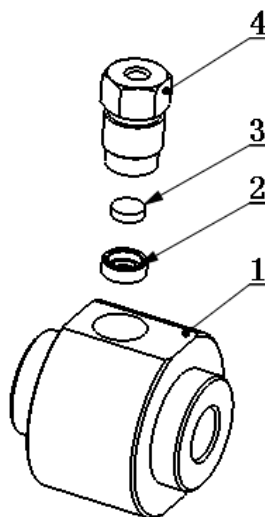

Figure 5-3: Assembly of the online filter

1. Online filter seat ,2. Filter disc,3. Sealing ring, 4. Pressing cap

5.5 Cleaning the pump head

Crystalline salt may appear when using buffer salts for a long time. Crystalline salt is harmful to the seals and plunger rod. In order to avoid this situation, cleaning should be carried out frequently on the flow path and sealing ring. Customers can prepare a suitable cleaning fluid (such as distilled water and 10% methanol, 20% ethanol aqueous solution, etc.). Plunger rod cleaning device has been allocated as standard in the high pressure constant flow pump. Select a suitable cleaning method refer to please refer to Figure 5-4 according to the need.

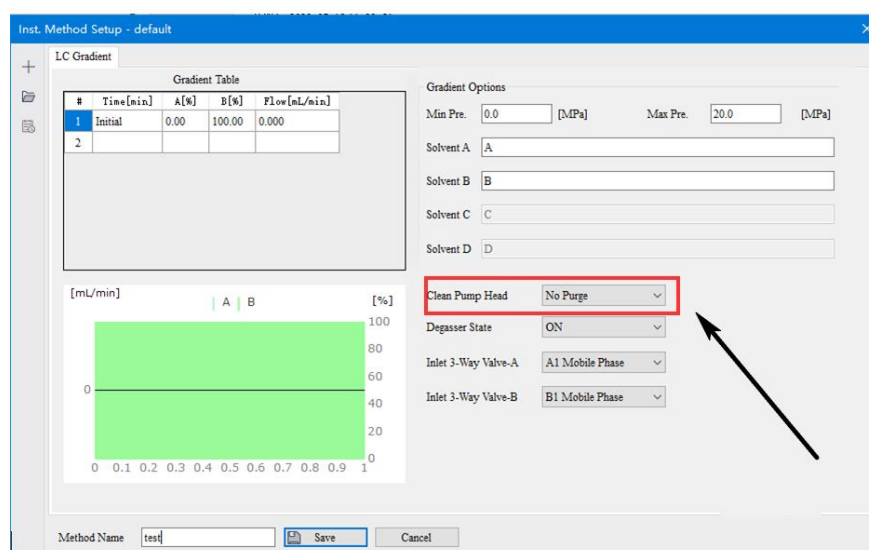

Figure 5-4: Cleaning the pump head

There are three kinds of cleaning the pump head methods, which are No Purge, Intermittent purge and Always purge. The intermittent purge is a flushing cycle of 5 min, 10 seconds per cycle, the flushing speed is 6 mL/min, and the cleaning solution is about 12 mL per hour. The flushing speed of the Always purge and intermittent purge is the same. The user can add the flushing solution timely according to the flushing method he chooses.



【Note】

Add and replace the cleaning fluid in time.

5.6 Pump Head Assembly

There is no need to open the case cover when removing the pump head. Methods for pump head disassembly and installation are as follows:

- 1) Turn off the pump power.
- 2) Remove the infusion line connected with the pump.
- 3) Use 3# hexagonal key (Allen key) to unscrew the 4 pump head screws and remove the pump head body.
- 4) When installing the pump head, pay attention to evenly tighten the four fixed screws, referring to Figure 5-5.
- 5) Connect the infusion line removed in step 2 above.

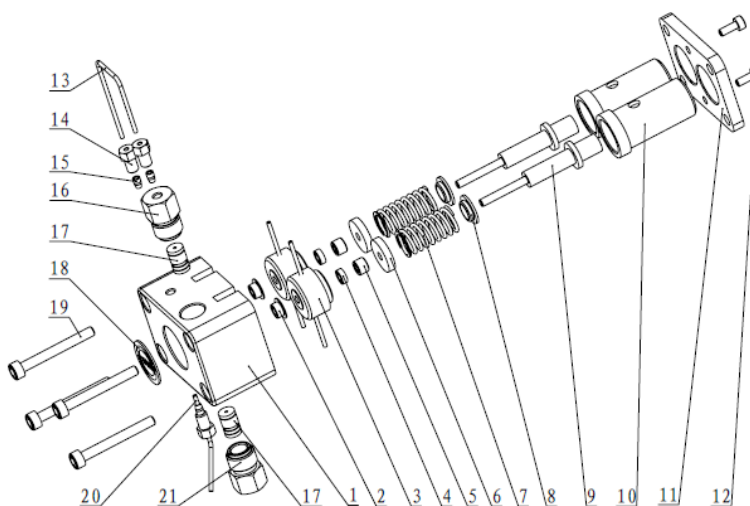

Figure5-5: pump head assembly

1. Pump head body, 2. Plunger seal, 3. Support ring with plunger rinsing, 4. The secondary seal, 5. The secondary seal pressure ring 6. Spring outside locating sleeve, 7. Plunger spring, 8. Spring inside locating sleeve, 9. Plunger rod components, 10. Sleeve, 11. Mounting plate, 12. Mounting plate screw, 13. Stainless steel tube, 14. Tube screw, 1/16" I.D., 15. Stainless steel ferrule, 1/16" I.D., 16. Export pressure cap, 17. Check valve, 18. Badge of the pump head, 19. Pump head screw, 20. Outlet pipe, 21. Entrance pressure cap

5.7 Pump head disassembly and installation methods

Pump head disassembly and installation methods are as follows (Refer to Figure 5-5, Figure 5-6):

- 1) Place the pump head body on a flat surface. Use 2.5# hexagonal key to unscrew the 2 mounting plate screws, #12 on Figure 5-5. Remove the clamp (10#).
- 2) Unload the sleeve (figure 5-5 #10), plunger rod components (figure 4-3 #9), plunger spring (figure 5-5 #7), locating sleeve (figure 5-5 #3) etc.
- 3) Observe the plunger rod surface with a magnifying glass to find whether axial wear occurs on it. If there is no axial wear, clean the plunger rod, or a new plunger rod is needed.
- 4) Take out the primary seal carefully (figure 5-5 #2) (user should not remove it unless replace a new one is needed).
- 5) Put the new primary seal (the openings with spring should be in the direction of the pump head) into the pump head body (Figure5-6 #1).
- 6) Place all parts in order according to Figure5-6. Install the pressure plate.
- 7) Put the pump head on worktable, push the pressure plate slowly, press the two-pressure plunger rod into the primary sealing ring, and then tighten two fixed screws evenly.

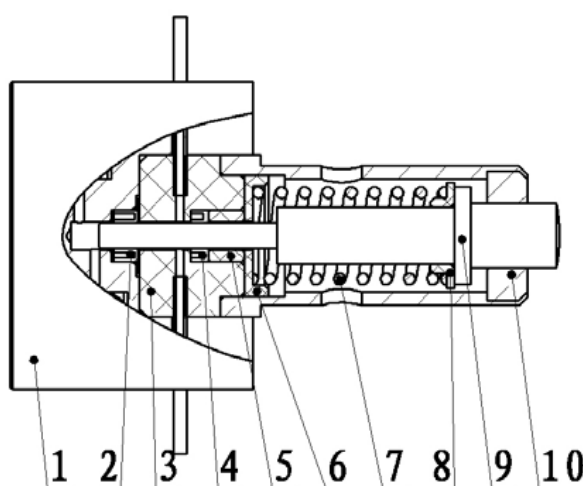

Figure 5-6: Cross-section of sapphire plunger

1. Pump head body 2. Plunger seal 3. Supporting ring with plunger rinsing 4. Primary seal 5. The secondary seal pressure ring 6. Spring outside locating sleeve 7. Plunger rod spring 8. Inside spring locating sleeve 9. Plunger components 10.Sleeve



【Note】

Plunger rod is easy to break. Be careful while unloading and assembling.

5.8 Relief valve seal replacement

The sealing ring of the relief valve is a consumable part, and leakage may occur after long-term use. At this time, the sealing ring must be replaced. The specific replacement steps are as follows:

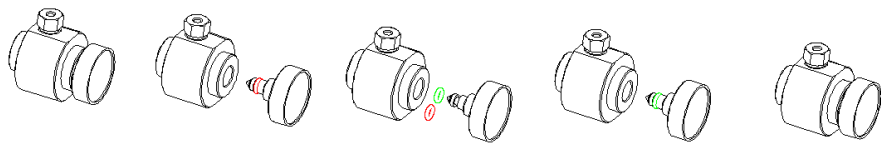

Figure 5-7: Relief valve seal replacement

- 1) Rotate the relief valve handle counterclockwise until it is completely disengaged.
- 2) Use sharp tools (such as sharp tweezers, etc.) to pick out the old sealing ring out of the limit groove.
- 3) Re-fix the new sealing ring in the limit groove.



【Note】

Provide special support tools can make installation faster, easier, violence installation may damage the sealing ring.

5.9 Peristaltic pump silicone tube replacement

In order to avoid the formation of crystallization, use the buffer as the mobile phase and activate the peristaltic pump cleaning device. Silicone tube peristaltic pump belongs consumable part, prolonged use of silicone tube to aging. Therefore, it is recommended that the customer replace the silicone tube once every six months. The specific replacement method is as follows:

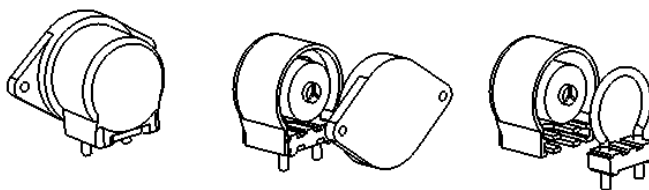

Figure 5-8: Peristaltic pump silicone tube replacement

- 1) Disconnect the outlet and inlet tubes of the peristaltic pump.
- 2) Counterclockwise rotation of the peristaltic pump housing cover, the housing cover is opened.
- 3) Pull out the buckle at the lower end of the shell cover (at a perpendicular angle to the shell cover) to take out the silicone tube.
- 4) Place the new silicone tube along the inner wall of the peristaltic pump.
- 5) Fasten the buckle, align the housing cover with the peristaltic pump and rotate it clockwise to install the housing cover.
- 6) Connect the outlet and inlet pipes of the peristaltic pump.



【Note】

To ensure the normal operation of the peristaltic pump, please use the special silicone tube provided.

5.10 Installation of degasser

Degasser is used in P3200L high pressure constant current pump as an optional accessory. In order to facilitate the installation on site, the installation of degasser is introduced here:

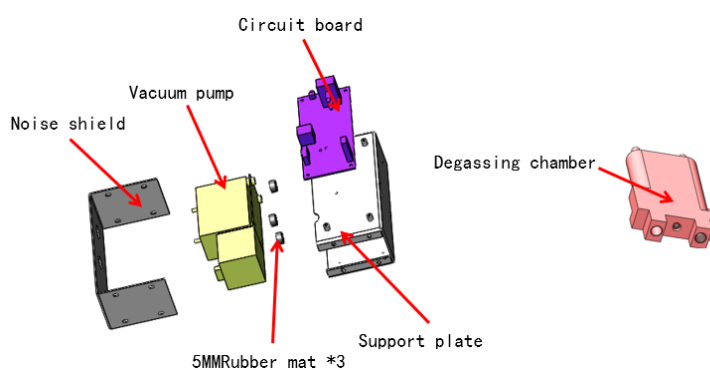

Figure 5-9 Components of a deaerator

- 1) Disassemble the 2-yuan degasser. The main module consists of 1 vacuum pump, 3 sets of vacuum pump fixing screws, 1 circuit board, 2 degassing cavities (including pipelines), 2 sets of degassing cavity fixing screws, vacuum pump and circuit board connection, and 4 red plugs.
- 2) Use the vacuum pump fixing screws to fix the vacuum pump and three 5mm rubber pads on the deaerator support plate, as shown in the direction shown in the figure. Pay attention to the position of the semi-circular groove on the deaerator support plate.
- 3) Secure the deaerator circuit board to the deaerator support plate using M3*8 stainless steel cross-recessed pan head screws and steel paper pads, as shown in Figure 5-9.
- 4) After connecting the vacuum pump to the circuit board, fix the noise shielding cover on the deaerator support plate using M3*8 stainless steel cross slot pan head combination screw, as shown in directions 5-9.
- 5) See Figure 5-9 for securing the front panel.
- 6) Refer to Figure 5-13 to stack degassing chambers alternately and fix them on the front panel of the pump (degassing chambers are connected by pipes, see accessories sequence).

Deaerator wiring harness connection

There will be two wires in the deaerator accessories, one deaerator J4

harness and one deaerator power harness.

Deaerator J4 wiring harness connection:



Figure 5-10 Connecting the deaerator J4 wiring harness

- 1) Assemble the degaser according to Figure 5-9 and fix it on the bottom plate of the pump;
- 2) Locate the pump motherboard and connect the deaerator J4 wiring harness according to Figure 5-10 (Refer to the direction of the motherboard in the figure, the second row from the right or the fourth row from the left);

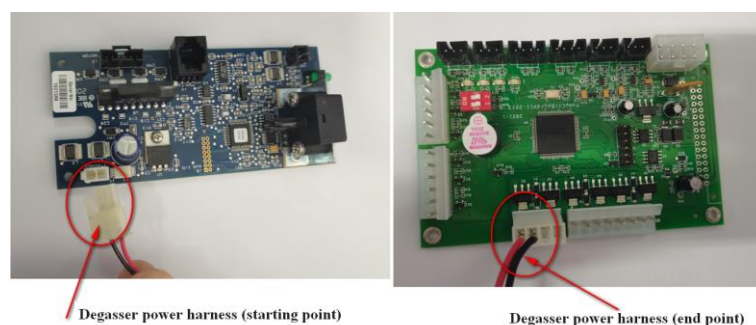

Figure 5-11 Connecting the deaerator power harness

- 1) Locate the corresponding circuit board on the pump, as shown in Figure 5-10;
- 2) Connect the deaerator power harness to the first row seat at the bottom of the circuit board as shown in the figure;

The deaerator installation has been completed.



The customer must install the cable harness on the correct rows under the guidance of engineers on site.

5.11 Solenoid valve replacement

The solenoid valve is used as an optional part in the P3200L high pressure constant current pump. In order to facilitate on-site installation, the installation of the solenoid valve is described here:

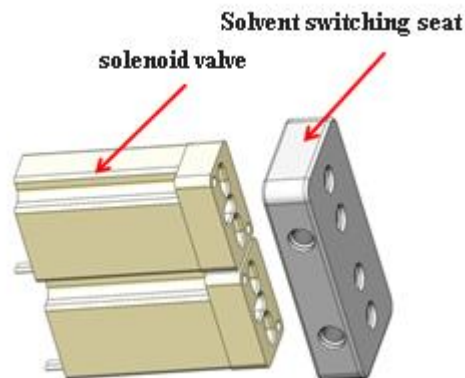

Figure 5-12 Solenoid valve and accessories

- 1) Assemble the solenoid valve and the solvent switching seat together with the screw provided by the solenoid valve. Note that the outlet end of the solenoid valve faces downward according to the direction shown in the figure;
- 2) Tightening torque is 0.05NM;
- 3) Fix the solvent switch seat to the front panel by screws on the cover plate of the solenoid valve.

Solenoid valve harness connection:

The solenoid valve of the pump is divided into two solenoid valves, A and B, each valve has only 1 wire harness, after the solenoid valve is fixed, refer to the following figure for wire harness connection:

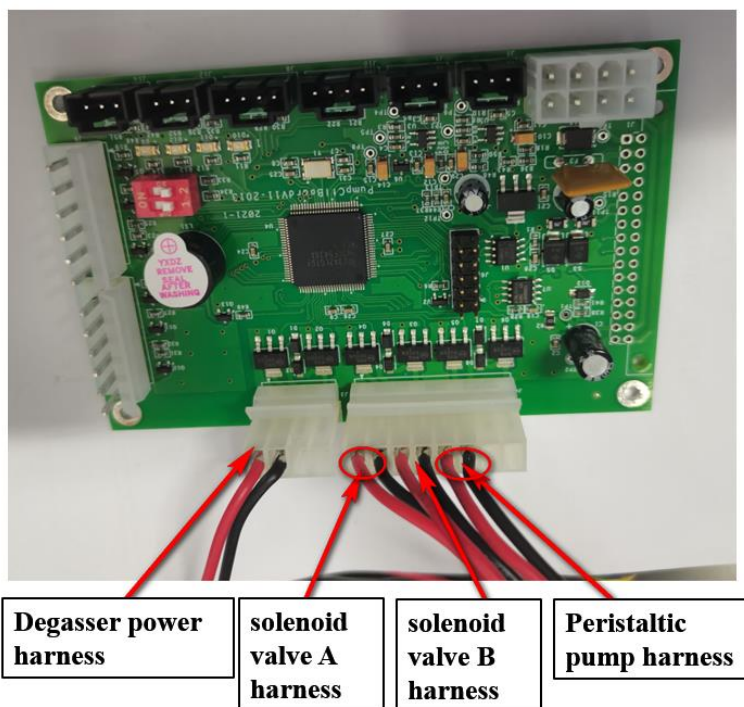

Figure 5-13 solenoid valve harness connection

- 1) First, find the peristaltic pump wiring harness (common with the solenoid valve wiring harness);
- 2) Find the corresponding row seat on the pump control board along the peristaltic pump wiring harness;
- 3) Refer to Figure 5-13 and install the wiring harness of solenoid valve A in the right hole of the peristaltic pump wiring harness in the sequence of red to black on the left;
- 4) Install the wiring harness of solenoid valve B on the right hole of the wiring harness of solenoid valve A in a red-black sequence, as shown in the following sequence. Install it on the front panel, as shown in Figure 5-14.

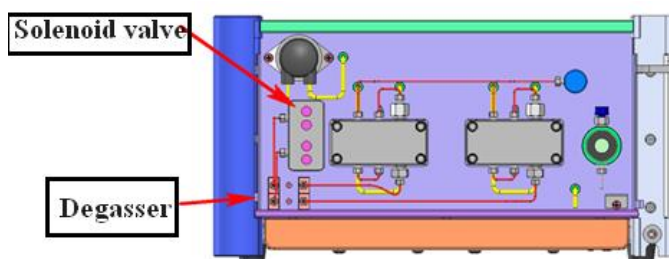

Figure 5-14 Connecting pipes on the front panel

Components and Material list

6.1 Consumption parts

NO.	Describe	PN
1	3/16"-32 SS Nut	14510027
2	1/16"SS Ferrule	14990070
3	1-16 Solenoid Valve Connecting Screw	14992845
4	1/16"Omni-Lok	33120148
5	PTFE Tube O.D.1/16" ~ I.D.0.03"	13010031
6	3220 Solvent Filter	18050035
7	1-8 Solenoid Valve Connecting Sscrew	14992844
8	1/8"Omni-Lok	33120019
9	PEEK Finger TightI	3215F-120X
10	Twist-Pair	17000116
11	Power Cable	17000119
12	Silicone Tubing OD3.0 mm × ID1.0 mm	13010033
13	Mobile Phase Bottle, Transparent, 500mL	33110001
14	Mobile Phase Bottle, Transparent, 1000mL	33110002
15	Mobile Phase Bottle, Transparent, Brown, 500mL	33130008
16	Mobile Phase Bottle, Transparent, Brown, 1000mL	33130009
17	Liquid System	18990159
18	T2AL250V fuse	15080006
19	O-rings Φ 5.3x1.8	14991024
20	O-rings Φ 3.5x1.8	14992280
21	Sealing Ring	14990054
22	Filter Disc	14510075
23	Primary Seal	14990076
24	Secondary Seal	14990074
25	Plunger Rod	14010215
26	Ccheck Valve Component	14010012
27	H-Primary Seal	14993209

6.2 Optional parts

NO	Item	Item	Item
1	Gradient Mixer	GM3200-800	31060232
2	Gradient Mixer	GM3200-50	31060230
3	Damper	DP3200-50	18010243
4	Damper	DP3200-30	18010284

**【Note】**

The pressure range of the DP3200-50 damper (Open volume 200 μL) is 0 to 70MPa; The GM3200-800 gradient mixer (Volume 800 μL) and the GM3200-50 gradient mixer (Volume 50 μL) and DP3200-30 damper (Open volume 80 μL) use pressure ranges from 0 to 90MPa.

Appendix

Introduction to the connecting tube materials

In HPLC systems, column systems, tubing, fittings, and extra-column volumes in the injectors and detectors are likely to cause peak broadening. Improper tube material will also lead to peak broadening, even cause the sample degeneration, which affects the reliability of analysis results directly.

Good connection can fully exert the function of the instrument and improve the work efficiency. Different tube material is needed according to the system pressure and the properties of mobile phase and samples. Commonly used pipe materials include stainless steel, polyether ether ketone (PEEK), Teflon, polytetrafluoroethylene vinylidene fluoride, polyethylene or polypropylene. The stainless-steel pipe is the most commonly used.

Outer diameter of HPLC system connecting pipe is 1/16"(1.59mm). Inside diameter can be chosen according to your need. Commonly used inside diameter includes 0.007"(0.175mm) , 0.01"(0.25mm), 0.02"(0.5mm), 0.03"(0.75mm) and 0.04"(1.0mm) etc.

Stainless steel tube is generally used in high pressure part. In HPLC systems, the part from the pump to the column inlet is high pressure section. Stainless steel tube is recommended.

Stainless steel tubing has good corrosion resistance and coaxially. The bore of the pipe should match that of the fitting well while using it.

Also, polymer tubing can be used in many sections of HPLC systems, such as low-pressure parts: from the liquid bottle to the pump, the detector outlet, the sampler drainage port, the emptying valve outlet and others. Teflon is inertial to HPLC solvents and is the most commonly used plastic pipe.

When the pressure is lower than 20MPa, peek tubing is lazier than stainless steel tubing and is suitable for biological sample analysis.

Safety information

General safety information

At the different stages of the instrument operation, maintenance and repair, everyone should abide the following general safety rules. Breaking these rules may cause damage to instruments or staffs. Our company does not responsible for the impact caused by non-standard operation.

Standard of security

For marked with this symbol of the equipment, the user should refer to the instruction manual, so as not to cause harm to the operator and the equipment.

Symbols	Descriptions
	Please do not operate beyond the scope of caution, unless you have been fully understood and meet the required conditions.
[Warning]	Casualties may appear. Please do not operate beyond the scope of warning, unless you have been fully understood and meet the required conditions.
[Caution]	Data loss or equipment damage may appear. Please do not operate beyond the scope of caution, unless you have been fully understood and meet the required conditions.
[Note]	Unsatisfactory experimental data and instrument failure may appear. Please do not operate beyond the scope of note, unless you have been fully understood and meet the required conditions.

