

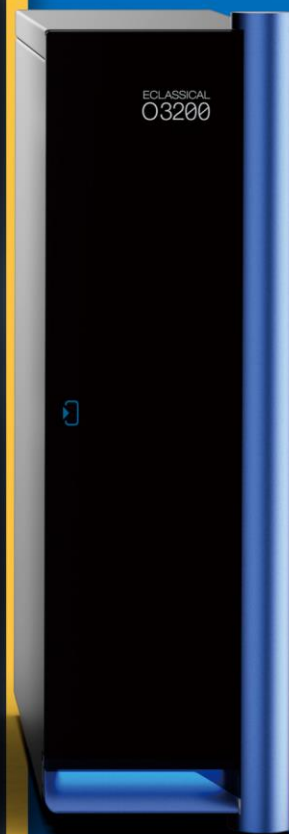

ECLASSICAL 3200

HPLC

USER MANUAL



Operation Manual

for O3220 Column Oven

V1.0.6

Statement

The manual is intended to help users to understand, use and maintain O3220 column oven. Dalian Elite Analytical Instruments Co., Ltd. does not assume the responsibility caused by business or special purpose use of the manual.

The information in this document is subject to change without notice and should not be construed as a commitment by Dalian Elite Analytical Instruments Co., Ltd.

This manual is believed to be complete and accurate at the time of publication. Dalian Elite Analytical Instruments Co., Ltd assumes no responsibility for any errors that may appear in this document.

In no event shall Dalian Elite Analytical Instruments Co., Ltd be liable for incidental or consequential damages in connection with, or arising from, the use of this manual.

The Copyright of the manual is owned by Dalian Elite Analytical Instrument Co., Ltd. This book or parts thereof may not be reproduced in any form without the written permission of the Dalian Elite Analytical Instrument Co., Ltd.

Please read the document carefully before using O3220 column oven.

Foreword

Thank you for purchasing our equipment. To ensure correct and safe use of the instrument, please read it carefully before using.

The details of the equipment's composition, installation, method of using, maintenance, parts selection and other points are described in the manual. After reading, please keep it carefully. Please delivery the manual with the instrument.

For safe operation, please read the following **Safety Precautions** before using the instrument.

Safety Precautions

According to the level of danger and harm, safety signs here are divided into the following three categories:



[Warning] Failure to properly follow the instructions and precautions indicated by this sign may result in serious injury or damage to health and property. The property damage include the environment around and the instrument.



[Caution] Failure to properly follow the instructions and precautions indicated by this sign may result in slight injury or damage to health and property. Slight injury means no hospitalization is needed to the wounded. Slight property damage means the instrument can be recovery through simple maintenance.



[Note] The sign is used wherever information is given to ensure optimal performance of the instrument.

1. Precaution for usage



[Warning] O3220 Column Oven should only be used as a part of liquid chromatography. Do not use it for any other purpose. Except for special instructions, this instrument does not have explosion-proof function.

2. Ambient Conditions



[Warning] When we use organic solvent it is recommended that interior must be well ventilated and the firework should be prohibited. Also, a sink or equipment for washing eyes should be installed nearby in case of the organic solvent coming into contact with the eyes or skin.



[Note] In order to ensure good efficiency, keep the instrument away from caustic gas, dusty environment or strong magnetic. The worktable should be wide and strong enough. Ambient should be between 10°C to 30°C with a small fluctuation, and humidity should be between 20% to 80%. Avoid it from cold or hot source as well as direct sunshine. The air conditioners and other equipment should not blow directly into the instrument.

3. Precaution for installation



[Warning] The instrument should be installed following the instructions strictly by professionals, make sure that the voltage of the power socket is the same as the power supply voltage indicated on the instrument. Using the wrong power voltage could result in danger and fire.

The accessory power cable should be used to connect the pump to the power socket. Other cable should not be used.

Make sure the line cord is connected to a properly grounded power receptacle to prevent static and electric leakage.



[Caution] The instrument is so heavy that you should move it carefully and watch your hands in the same time.



[Note] The instrument should be connected following the instructions strictly. Wrong connection could cause communication error.

4. Precaution for use



[Warning] Do not use the instrument in places where heat resource, fire seat, magnetic resource, strong vibration exist or may exist. It is prohibited to put flammable nearby.

The bottle for storing the mobile phase should have a pore in cap to prevent the danger caused by negative pressure in the bottle.

A gap between the waste tubing and the cork of the waste bottle is necessary to prevent the waste bottle bursting when it is overfilled. But the gap should be small to prevent evaporate of hazardous solvents. Even though, the waste needs to be clean up promptly.



[Caution] When using organic solvents, please wear safety goggles, special lab coats, gloves mask etc. If your body contact with toxic solvent accidentally, wash it immediately, and then go to hospital for specialized treatment.



[Note] When preparing mobile phase, please use HPLC grade solvents or equivalent ones. You'd better filtrate the eluent with a membrane filter (0.45 μ m), and an online filter is also necessary to prevent small particles from scratching plunger rod, seal ring or blocking tubing. What's more, please degas all mobile phase before using, degassing is an effective method to prevent chromatogram noise and wrong indicator.

Before first use, rinse the entire piping system according to the requirements of the manual. Direct use is likely to block tubing.

Before sample test, ensure that the tubing in the system is filled with mobile phase without any bubbles, otherwise it will affect the reliability of test results.

If an eluent is replaced with another eluent which is insoluble, such as positive mobile phase (hexane) and reverse phase (methanol), be sure to operate according to the specified method in the manual, otherwise it will cause serious tubing jam, and even system paralysis.

Halogen ions is harmful for stainless steel, if there is stainless steel tubing and fitting in your system, please avoid the use of a mobile phase containing halogen ions. If you can't avoid it, please minimize the content and clean the system with water as soon as finishing the analysis.

If there is peek tubing in your system, it is important to note that:

Do not use the following solvent: concentrated sulfuric acid, nitric acid, dichloroacetic acid, dichloromethane, chloroform, chloroform, dimethyl sulfoxide, acetone, tetrahydrofuran, etc. Such solvents can reduce the strength of the PEEK material, make it's become fragile and broken. But the impact of short-term use of aqueous solution of acetone (lower than 0.5%) in gradient performance is acceptable.

When using PEEK tubing, the pressure of the system should be lower than the tolerance pressure of peek material, otherwise it may burst.

The bending radius of peek tubing should be more than 10mm, make the peek tubing natural relaxation during installation.

The PEEK tubing should be intercepted with professional tubing cutter in order to make the tubing smoother. Pay attention to that there should be no cutting debris left in the tubing.

5. Repair, maintenance and parts replacement



[Warning] Before repair, maintenance and parts replacement, please turn off the power in case of leakage and electric shock.

There is no need to open the host cover while daily maintenance and repair. If the repair needs to open the host cover, please entrust agents or communicate with us.

You should clean the dust on the power cord plug regularly to reduce the electrostatic. Then, dry it before using, otherwise electric shock may occur.

Use dry cloth to wipe the instrument. Do not use thinner or alcohol to avoid erasing characters or color on the panel.

Do not replace components (e.g., fuses, deuterium lamp, etc.) from other company or other type, all accessories are required to be specified to prevent danger.

6. Precaution for static electricity



[Warning] As the instrument may use a lot of flammable, explosive organic reagents which may contaminate laboratory air, when the reagent concentration is too high, any spark or flame could cause fire or explosion accidents. Do not use the pump near any fire resource or hot resource and keep reducing the electrostatic in mind. To reduce static electricity, please take the following measures:

- 1) Make the instrument grounded. It is very important, please pay attention to it.
- 2) Maintain proper indoor humidity (humidity is greater than 65% can prevent static electricity effectively) and keep the environment clean.
- 3) Metal waste bottles (external conductive) should be grounded (no ground insulation). When using other materials container, you can insert one end of the wire into liquid in the bottle and make the other end earthed.
- 4) Replace a larger I.D. tubing when the flow of mobile phase is higher than usual.
- 5) Wipe the instrument regularly.
- 6) Staffs should wear anti-static clothing. An anti-static pad is needed on the floor.
- 7) People and objects with static electricity is prohibited to touch the instruments.

7. Warning label instructions

To ensure the safety of staffs, we attach warning labels on the equipment where are dangerous. If the label is missing, please request new ones from our company, and attach to the correct position.

Contents

CHAPTER 1 INTRODUCTION	1
1.1 Overview	1
1.2 Features and Functions	2
1.3 Performance Specification	2
1.4 Physical Specifications	2
CHAPTER 2 INSTALLATION AND TRANSPORT	3
2.1 Unpacking inspection and standard accessories	3
2.1.1 Demolition of the packing	3
2.1.2 Deliver checklist.....	3
2.2 Stack Order	4
2.3 Installation Requirements	5
2.3.1 Site Requirements	5
2.3.2 power line.....	7
2.3.3 Computer requirements.....	7
2.4 O3220 Rear	8
2.5 Column Connection	9
2.5.1 Installation site	9
2.5.2 Column tube connection	10
2.5.3 Connecting the column with protect column.....	11
2.6 Transportation.....	12
CHAPTER 3 BASIC OPERATION	13
3.1 Power On.....	13
3.2 Run	16

CHAPTER 4 DAILY MAINTENANCE	18
4.1 Attentions	18
4.2 The fuse replacement	18
CHAPTER 5 COMPONENTS AND MATERIAL LIST	19
5.1 Consumption parts	19
5.2 Replacement parts	19
APPENDIX	20
Introduction to the connecting tube materials	20
Safety Information	21
General safety information	21
Standard of security	21

Chapter 1 Introduction

1.1 Overview

EClassical O3220 Column Oven (abbreviated as O3220) is one of the EClassical 3200 series products developed by Elite. O3220 Column Oven is a new type of high-performance liquid chromatography column oven with independent intellectual property rights.

As a temperature control unit of HPLC system, O3220 can be used with other units of HPLC system such as liquid chromatography detectors, auto sampler, pump, as well as be a independent temperature control tool.

Thanks to the latest design of heating and control module, the key indicators including Heating speed and temperature control stability are greatly improved. The operation interface is simple and intuitive. And you can see the setting temperature and real-time temperature on the screen in the same time. What's more, overtemperature alarm, temperature protection and power outages, temperature calibration, piping hot, and many other functions are adding to O3220, all these make O3220 Colum Oven safe and convenient. It can be used in medicine, biological, environmental protection and quality control etc.

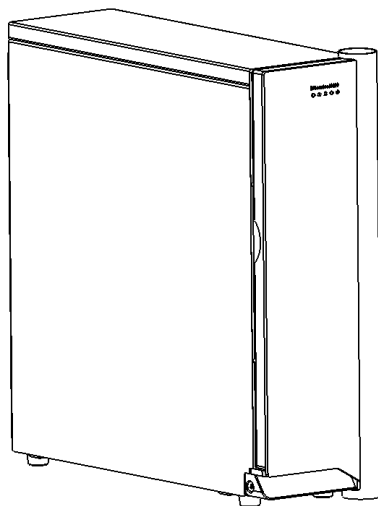

Figure 1-1: O3220 column oven

3220 Series products include O3220 column oven, UV3220 UV - visible detector, P3220 constant flow pump, high pressure injector, and the workstation etc. For more information, please contact Dalian Elite Analytical Instruments Co., Ltd.

1.2 Features and Functions

Draw lessons from the current domestic and foreign advanced technology, the company independently developed O3220 column oven which has independent intellectual property rights, the features of O3220 is shown as follows:

The PID subsection control technology make the controlled temperature increase quickly and rush small, so, the balance time is shortened greatly.

With high precision temperature sensor, temperature calibration function and built-in temperature calibration curve method, the temperature in column oven is accuracy and repeatable.

Alarm, short circuit protection function guarantees the safety of instruments.

O3220 can be connected to workstation with internet cable and be controlled conveniently by the workstation.

Use air heating, increase circulated air function, greatly reduce the temperature gradient.

Using high integration of stm32 microcontroller and SMT packaging device, the size of the circuit board is reduced, and the reliability is improved.

The preheating pipeline of chromatographic column is added to ensure constant mobile phase temperature and improve the separation repeatability of chromatographic column..

1.3 Performance Specification

Table 1-1: Performance Specification for O3220 column oven

Items	Specifications
Temperature range	Ambient temperature+5 °C~85 °C
The highest alarm temperature	90 °C
Accuracy	≤±0.5 °C
Precision	≤0.1 °C
Distinguishability	0.1 °C
Stable time	≤15 min
Rush temperature	≤1.0 °C
Communicate mode	internet access

1.4 Physical Specifications

Table 1-2: Physical Specification for O3220 column oven

Dimension/Weight	440 mm×160 mm×470 mm/11 kg
Power Supply	AC 220 V(±10%), 50 Hz
Power	130 W

Chapter 2 Installation and transport

2.1 Unpacking inspection and standard accessories

O3220 column oven is packaged with corrugated boxes and foam lined structure, as you receive the instrument, check the packaging first, if you found packaging is damaged, please contact with Dalian Elite Analytical Instruments CO., Ltd. or local dealer.



[Warning] If there is any damage to the instruments when you receive it, please don't try to install it. You can ask Dalian Elite Analytical Instruments CO., Ltd to inspect and assess it.

2.1.1 Demolition of the packing

Put the instrument on level ground with the face of the packing box up. Cut the tape on the top, take out the column oven and accessories package, place it on the table. Then, remove foam, open the instrument protective film.



[Warning] It is suggested that installation operation should be careful to prevent instrument slide or damage to health.

2.1.2 Deliver checklist

Before installing, please check the deliver list carefully, if one or several of them are missed, please communicate with Dalian Elite Analytical Instruments CO., Ltd. or local distributors as soon as possible.

Table 2-1: Deliver list of O3220 column oven

NO.	Items	Quantity
1	O3220 column oven	1 pc.
2	Certificate	1 pc.
3	Service Card	1 pc.
4	Start Package	1 pc.
5	O3220 user manual CD)	1 pc.



[Note] If there are discrepancies between the packing list in the box and in the specification, please refer to the packing list in the box. It is subject to change without prior notice.

2.2 Stack Order

In order to guarantee the best working state of the instrument, it is recommended that the instruments should be stacked as shown in figure 2-1.

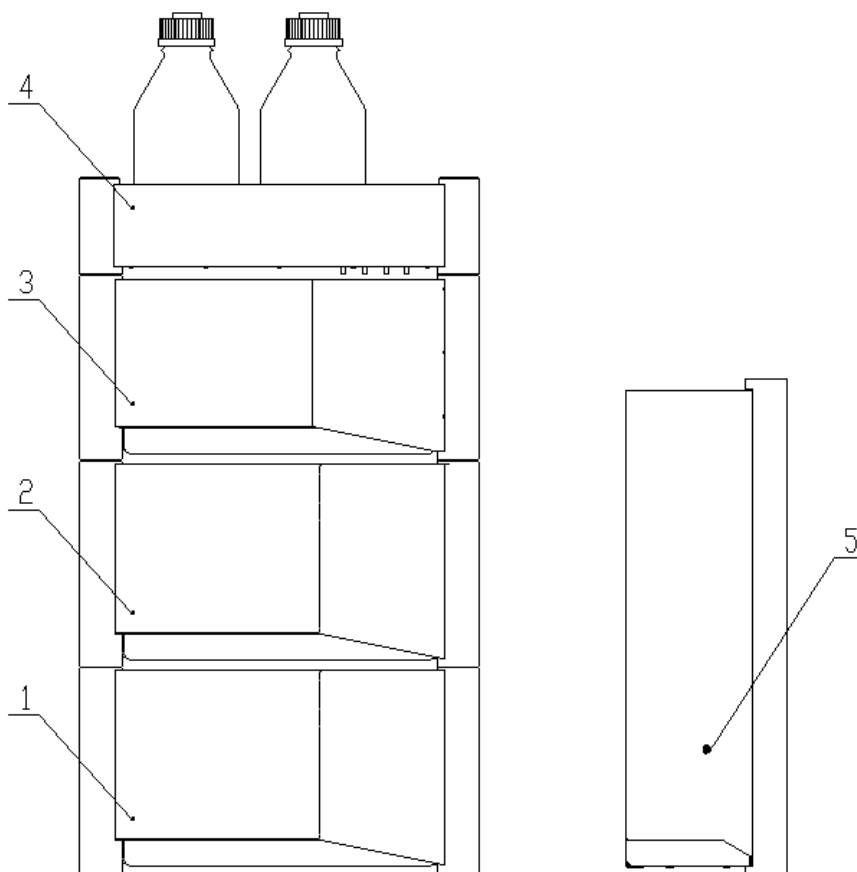

Figure. 2-1: EClassical3220 stack order

1. High pressure constant flow pump, 2. Auto-sampler, 3. Column oven,
4. Solvent manager, 5. Column oven

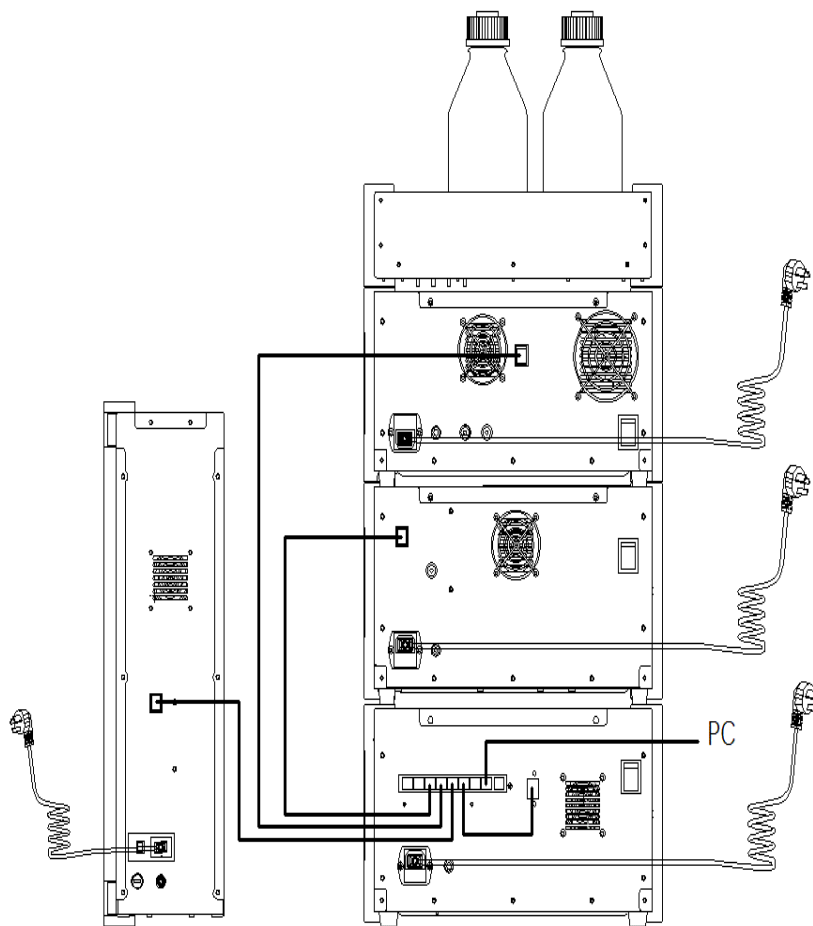

Figure. 2-2: EClassical3220 rear panel diagram

2.3 Installation Requirements

2.3.1 Site Requirements

Environment

O3220 column oven need to work under ambient conditions in table 2-2 below:

Table 2-2: Environment requirements

Items	Specifications	Requirements
1	Work environment	Room should be free of dust, inflammable and explosive materials, also, good ventilation is important
2	Electromagnetic field	No electromagnetic noise nearby
3	Operating temperature	5~35°C (41~95°F)
4	Humidity	20%~80%, non-condensing
5	Temperature fluctuation	<±2°C/hr



[Caution] Do not use the column oven under conditions of temperature fluctuations. If the ambient temperature is too low, make the room temperature increase slowly to avoid condensation inside caused by rapid heating.

Bench space

O3220 column oven should be placed close to the computer and detector. O3220 column oven requires an area of 450×150mm, and the table should be stable and level. It needs an additional 50mm on the left,20mm on the right,80mm on the back to facilitate the electrical connections.



[Warning] The instruments should be placed on a horizontal position, otherwise there is a danger of falling!

2.3.2 power line

To ensure that the instrument can be normal and safe, please use a dedicated power line within the specified voltage range.

Grounding, T1.25A (250V) fuse.



[Warning] The accessory power cable should be used to connect the column oven with the power socket. Other cable should not be used in case of danger or damage to the instrument.

If the instrument is connected to a grid above the scope of application, it may cause electrical shock or damage to the equipment and staff.

Please unplug the power cord before replacing the fuse to avoid electric shock. The external fuse is installed in the back of instrument.

2.3.3 Computer requirements

Hardware requirements

- The lowest hardware requirement: Intel Core 2 CPU, 2G internal storage, more than 1G hard-disk space; (Refer to the use of workstation)
- The lowest resolution of displayer: 1024×800, 64K(16 bit image);
- Others: USB or RS232 interface for communication, CD-ROM driver for software installation.

Operation system requirements

- Windows XP Professional(SP3)、Windows 7 or higher version(Refer to the use of workstation).

Workstation requirements

- Use Kromstation/W5100 workstation to control the instruments.

2.4 O3220 Rear

The rear of O3220 is shown in Figure 2-4 and Figure 2-5., The corresponding functions are shown in Table 2-4 and Table 2-5. .

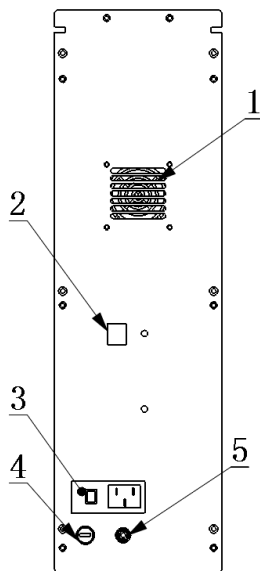

Figure 2-4: Rear of O3220

Table 2-4: Rear Components and Function

No.	Components	Function
1	Cooling fan vent	Cool the instrument.
2	LAN-2 interface	This socket is connected to High pressure constant flow pump for remote control.
3	Power connector and Power switch	The power cable is connected into grounded power outlet. Turn on /Turn off the power.
4	Fuse	Fuse is in it (T 1.25A).
5	Ground terminal	To ground the main body of the column oven.
6	Instrument panels	To identify the information of instrument.

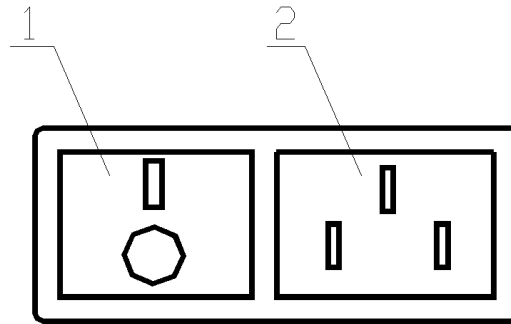

Figure 2-5: Power connector and Power switch

Table 2-5: Power connector and Power switch

No.	Components	Function
1	Power switch	Turn on the / turn off the power.
2	Power connector and	The power cable is connected into grounded power outlet.

2.5 Column Connection

2.5.1 Installation site

The column is installed as follows:

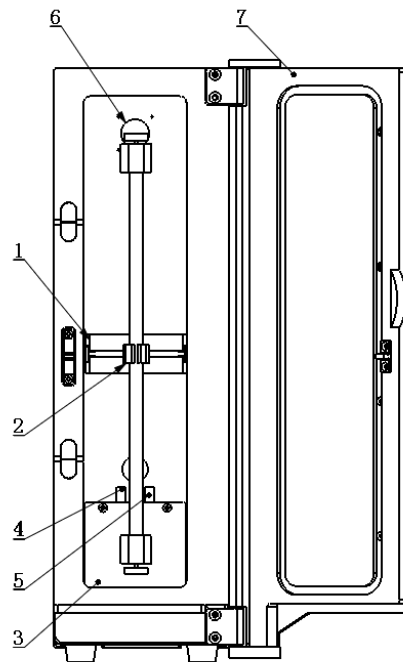

Figure 2-6: Column install

Table 2-6: The part name and function

No.	Components	Function
1	Column installation piece	Removable, easy to install different length of column
2	column clamp	To fix the column
3	the export for tube	To fix the column outlet tube
4	Side door	To shut down the heating chamber
5	pre-heating tube inlet	The inlet tube of mobile phase
6	turbo-blowe	To make gas flow circularly and reduce temperature gradient
7	column oven front door	To shut down the heating chamber

2.5.2 Column tube connection

- 1) Connect the pre-heating tube inlet of column oven to auto-sampler (or manual injector) with stainless tube (or PEEK tube)
- 2) Connect the pre-heating tube outlet to the column with stainless tube (or PEEK tube).
- 3) Connect the column to detector with stainless tube (or PEEK tube).
- 4) Put the connected column into the clamp, then, put the tubes in the tube guiding groove.
- 5) Run the pump, confirm that there is no leakage in the system.
- 6) Close the side door. The tube of column is connected well.

2.5.3 Connecting the column with protect column

If you need to connect a protect column, circuitous type connection is a good choice. if the total length of column and protect column is less than 310mm, linear connection can be chosen.



[Caution] In order to ensure the effect and efficiency of column, the diameter of connection tube should be as thin as possible, the length should be as short as possible.



[Warning] Many mobile phase used commonly are flammable and poisonous, once leakage occur, clean it carefully.

2.6 Transportation

Column oven is a precision instrument, please be gentle while long-distance transportation, severe vibration, drops are likely to cause damage to the internal parts of the instrument. The random original packaging can effectively protect the instrument. When the instrument is required to move or returned for service, please follow these steps for packaging.

- 1) Turn off the power.
- 2) Unplug the power cord and communication lines.
- 3) Remove the connecting pipe and other elements between components.
- 4) Remove the column oven from chromatography system, and then put it into special sealed bag on a large platform.
- 5) Put the column oven into the original packaging foam and fix it.
- 6) Place the fixed column oven and other accessories into original packaging carefully.
- 7) Tape the box sealed to prevent liquid from entering. Cover the packaging box with plastic wrap is recommended.
- 8) Transport packaged instrument.



[Warning] Before packing, please check the box, if the original packaging has been damaged, do not use it, you should consult your local dealer or Dalian Elite Analytical Instruments Co., Ltd. customer service staff to solve!

Chapter 3 Basic Operation

3.1 Power On

Please plug the power cord into the power outlet. The power should be turned off now (the power switch is “O”).

Turn on the power switch.

The power indicator light flashes, O3220 start self-inspecting, the indicator light is always on after self-inspection is finished. The status of O3220, the actual temperature and set temperature can be viewed in the device monitoring window,. (the default units °C)

There is a long strip indicator light below the front panel of the high pressure constant current pump, which is both a power indicator and a status indicator, as shown in Figure 3-1.

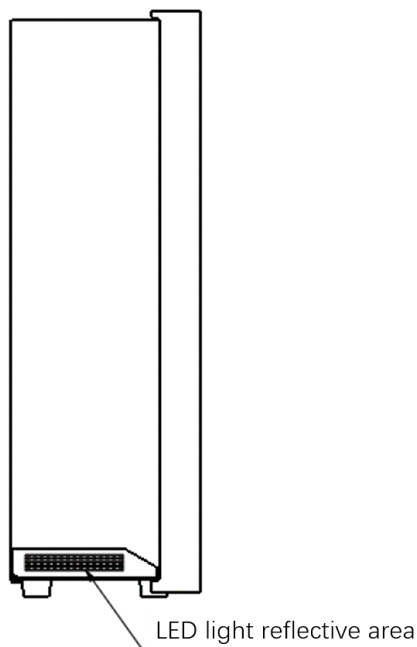

Figure 3-1: Column oven front panel diagram



[Caution] The indicator light can directly indicate that the instrument is in the state of power supply or dormancy as well as fault alarm. See Figure 3-2 for the specific

status and significance of the indicator light.

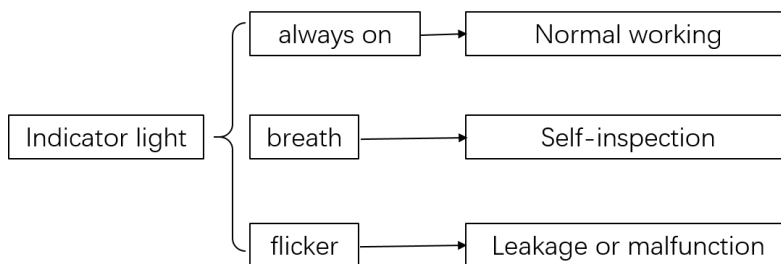

Figure 3-2 Indicator status and introduction



[Caution] If it is the first time to use the O3220 column oven, the parameters in the main interface after self-checking are the default parameters; otherwise, the O3220 column oven should keep all the parameters before last shutdown state.



[Caution] The temperature setting range can be changed according the setting value of alarm temperature. The largest range is +5-80℃.



[Caution] The highest withstand temperature of column should be considered when you setting alarm temperature.



[Caution] If the column oven is in alarm status, please check the setting alarm value. If the setting value is lower or close to the indoor temperature, please set it higher. If the column oven alarms several times without manual factor, please consult the customer service staffs.



[Caution] O3220 column oven is calibrated before sold, in the normal temperature (20°C-30°C) , calibration is not recommended. If you need calibrate it, please record the default calibration value well.

3.2 Run

The temperature of O3220 column oven is mainly controlled by Kromstation/W5100 workstation. After setting instrument parameters, save the method and run the method. At this time, the set temperature and alarm temperature can be seen in the device monitoring window.



Figure 3-3 Instrument method setting interface of the Kromstation workstation



Figure 3-4 Temperature setting interface of the Kromstation workstation column oven



Figure 3-5 Instrument method setting interface of the W5100 workstation

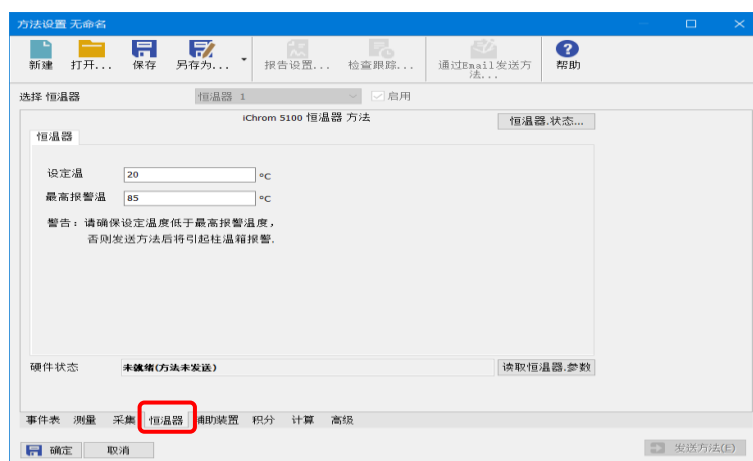

Figure 3-6 Temperature setting interface of the W5100 workstation column oven

Chapter 4 Daily maintenance

4.1 Attentions

- 1) In normal use, there is no need to have too much maintenance. But, In order to guarantee the use effect and repeatability, please pay attention to the several points.
- 2) The door of the column oven should be close well, otherwise, it will take a long time to get the setting temperature, or the actual temperature fluctuate a lot.
- 3) Keep the column oven clean, especially when the mobile phase leak from the tubes, clean it in time.

For safety, you'd better turn off the power when you want to change the column.

4.2 The fuse replacement

- 1) Turn off the power switch.
- 2) Remove the power cable from the power outlet.
- 3) Use a screwdriver to open the fuse butt cap.
- 4) After changing a new fuse, close the fuse cap.



[Caution] Please use the same fuse. Fuse type: T 1.25A/250V.

Chapter 5 Components and material list

5.1 Consumption parts

No.	Components	PN
1	General column joint	14510126
2	Stainless steel connection screws	14510027
3	1/16"Stainless steel blade ring	14990070
4	Stainless steel two way	14990115
5	OD1/16 " ~ID0.007 " stainless steel tube	12010005

5.2 Replacement parts

No.	Components	PN
1	Clamp parts (little)	14992427
2	Clamp parts (big)	14992428
3	T1.25A/250Vfuse	15080015
4	Power line	17000001
5	Communication line	18020038

Appendix

Introduction to the connecting tube materials

In HPLC systems, column system, piping, fittings, and outside the injector and Extra-column of detector are likely to cause peak broadening. Improper tube material will also lead to peak broadening, even causes the sample degeneration, which affects the reliability of analysis results directly.

Good connection can fully exert the function of the instrument, improve the work efficiency. Different pipeline material is needed according to system pressure, properties of mobile phase and samples. Commonly used pipe materials including stainless steel, polyether ether ketone (PEEK), Teflon, poly (vinylidene fluoride), polyethylene or polypropylene, the stainless-steel pipe is most commonly used.

Outer diameter of HPLC system is 1/16"(1.59mm). Inside diameter can be chosen according to your need, Commonly used inside diameter including 0.007"(0.175mm), 0.01"(0.25mm), 0.02"(0.5mm), 0.03"(0.75mm) and 0.04"(1.0mm) etc..

Stainless steel tube is generally used in high pressure part. In HPLC systems, from the pump discharge to column inlet part is high pressure section, stainless steel tube is recommended.

Stainless steel tube has good corrosion resistance and coaxially, bore pipe and joint should be matched well while using it.

Also, polymer tube can be used in many sections of HPLC system, such as low pressure parts: from liquid bottle to export pump, detector and sampler drainage mouth, emptying valve outlet and others. Teflon is inertial to HPLC solvent and is the most commonly used plastic pipe.

When the pressure is lower than 20MPa, peek tube is lazier than stainless steel tube and is more suitable for biological sample analysis.

Safety Information

General safety information

At the different stages of the instrument operation, maintenance and repair, everyone should abide the following general safety rules. Breaking the rules may cause damage to instruments or staff. Dalian Elite Analytical Instruments Co., Ltd. is not responsible for the impact caused by non-standard operation.

Standard of security

The safety class of this equipment I (to provide ground protection terminal), and it is manufactured and tested according to national safety standard.

Symbols	Descriptions
	Before using equipments marked with this symbol, please refer to the instruction manual first to avoid harm to the operator and the equipment.
[Warning]	Casualties may appear. Please do not operate beyond the scope of warning, unless you have fully understood and met the required conditions.
[Caution]	Data loss or equipment damage may appear. Please do not operate beyond the scope of caution, unless you have fully understood and met the required conditions.
[Note]	Unsatisfactory experimental data and instrument failure may appear. Please do not operate beyond the scope of note, unless you have fully understood and met the required conditions.

ELITEHPLC

About Elite

Suzhou Elite Science & Technology Co., Ltd.
701#, Building 10, Liandong U Valey, No. 179 Zhujiawan Street,
Gusu District, Suzhou, Jiangsu, China.
Tel: +86-512-67997535
E-mail: info@eliteHPLC.com
Web: <http://www.elitehplc.com>
