

# **Operation Manual**

## **for Elite GC2022 Gas Chromatograph**

**V1.0.0**

# Statement

The manual is intended to help users to understand, use and maintain [Elite GC2022](#). Our company does not assume the responsibility caused by business or special purpose use of the manual.

The information in this document is subject to change without notice and should not be construed as a commitment by us.

This manual is believed to be complete and accurate at the time of publication. Our company assumes no responsibility for any errors that may appear in this document.

In no event shall our company be liable for incidental or consequential damages in connection with, or arising from, the use of this manual.

The Copyright of the manual is owned by us. This book or parts thereof may not be reproduced in any form without the written permission of the our company.

Please read the document carefully before using [Elite GC2022](#).

# Foreword

Thank you for purchasing our equipment. To ensure correct and safe use of the instrument, please read it carefully before using.

The details of the equipment's composition, installation, method of using, maintenance, parts selection and other points are described in the manual. After reading, please keep it carefully. Please delivery the manual with the instrument.

# Content

<b>1 INSTRUMENT INTRODUCTION</b> .....	<b>1</b>
1.1 OVERVIEW .....	1
1.2 WORKING PRINCIPAL .....	1
1.3 INSTRUMENT FEATURES .....	3
1.4 TECHNICAL SPECIFICATIONS .....	5
1.4.1 Main Technical Parameters .....	5
1.4.2 Detector Technical Parameters.....	5
1.5 MAIN CONFIGURATION.....	6
1.5.1 Carrier Gas System.....	6
1.5.2 Injection System.....	7
1.5.3 Column System .....	8
1.5.4 Detection System .....	9
1.5.5 Temperature Control System .....	17
1.5.6Data Acquisition & Processing System .....	18
1.5.7 Auxiliary equipment.....	19
1.6 INSTRUMENT OPERATING ENVIRONMENT.....	20
1.6.1 Installation Environment .....	20
1.6.2 Power Supply Environment.....	21
1.6.3 Gas Supply Requirements .....	21
<b>2 INSTRUMENT INSTALLATION</b> .....	<b>23</b>
2.2 UNPACKING THE INSTRUMENT .....	23
2.2 INSTRUMENT INSTALLATION.....	23
2.2.1 Gas Source Installation .....	23
2.2.2 Pressure Reducing Valve Installation.....	23
2.2.3 Installation of external gas lines.....	24
2.2.4 System Leak Check.....	25
<b>3 OPERATION OF THE CHROMATOGRAPH</b> .....	<b>26</b>
3.1 STARTUP INTERFACE.....	26
3.2 HOMEPAGE .....	26
3.3 METHODS .....	29
3.3.1 Injection port .....	29
3.3.2 Chromatographic column .....	31
3.3.3 Column oven .....	31
3.3.4 Detector parameters .....	34
3.3.5 Events .....	35
3.3.6 Auxiliary.....	35
3.3.7 Options .....	36
3.4 DIAGNOSTICS.....	37
3.4.1 Zero Calibration .....	37
3.4.2 Factory Test .....	38
3.5 MAINTENANCE.....	39
3.6 LOG .....	40
3.7 SYSTEM SETTING .....	41
3.7.1 Configuration .....	41
3.7.2 System Setting .....	42
3.7.3 IP Adress .....	43
3.8 HELP .....	44
<b>4 INSTRUMENT MAINTENANCE AND UPKEEP</b> .....	<b>46</b>
4.1 MAINTENANCE OF THE INJECTION PORT .....	46
4.2 CLEANING OF THE HYDROGEN FLAME IONIZATION DETECTOR .....	46
4.3 INSTALLATION OF THE CHROMATOGRAPHIC COLUMN .....	46
4.3.1 Packing column installation.....	46

4.3.2 Installation of the capillary column .....	47
<b>5 INSTRUMENT FAULTS AND TROUBLESHOOTING .....</b>	<b>50</b>
5.1 STARTUP ISSUES .....	50
5.1.1 No response at startup .....	50
5.1.2 Not online .....	50
5.2 CHROMATOGRAPHIC PEAK ISSUES .....	50
5.2.1 No baseline .....	50
5.2.2 No chromatographic peaks.....	50
5.2.3 Normal retention time but decreased sensitivity.....	51
5.2.4 Tail peak .....	51
5.2.5 Tongue Extension Peak.....	51
5.2.6 Poor separation of chromatographic peaks .....	51
5.2.7 Baseline mutation.....	52
5.2.8 Irregular baseline fluctuations during constant temperature operation.....	52
5.2.9 Prolonged retention time leads to low sensitivity .....	52
5.2.10 The signal suddenly returns below baseline and extinguishes the fire when the peak comes out.....	52
5.2.11 Baseline too high .....	53
5.2.12 There are spike peaks in irregular distances.....	53
5.2.13 There is a certain amount of burrs at equal intervals.....	53
5.2.14 Round peak.....	53
5.2.15 Baseline noise is high .....	53
5.2.16 Extra peaks .....	54
5.2.17 Serrated baseline .....	54
5.2.18 Reverse peak.....	54
5.2.19 Baseline unidirectional baseline drift (FID) without injection .....	54
5.2.20 Irregular baseline changes during heating .....	55
5.2.21 Periodic baseline fluctuations.....	55
5.2.22 Baseline changes after programmed temperature rise.....	55
5.2.23 Uninjected Signal output amplitude too large (TCD).....	55
5.3 THERMAL CONDUCTIVITY DETECTOR PRECAUTIONS.....	56
<b>APPENDIX A ELECTRICAL REQUIREMENTS SPECIFICATION.....</b>	<b>57</b>
<b>APPENDIX B GROUNDING .....</b>	<b>59</b>

# 1 Instrument Introduction

## 1.1 Overview

Elite GC2022 Gas Chromatograph, meticulously designed as our next-generation instrument, integrates high integration, exceptional automation, user-friendly operation, and outstanding stability, specifically designed for prolonged, stable operation. Its superior performance in analyzing organic/inorganic compounds and permanent gases—across constant, micro, and trace levels—combined with its industry-leading cost-effectiveness, makes it the preferred analytical tool across diverse fields.

Whether in petroleum exploration & refining, chemical production & quality control, environmental protection & monitoring, food safety testing, disease prevention & control, or academic research, the Elite GC2022 GC delivers precise analysis and broad applicability, providing robust technical support. Its exceptional performance and economical cost-benefit ratio render this instrument indispensable for driving industry advancement and elevating scientific research standards.



## 1.2 Working Principal

Gas chromatography is a chromatographic separation analysis method that utilizes gas as the mobile phase. The vaporized sample is carried by the carrier gas (mobile phase) into the chromatographic column. Due to differential interactions between the stationary phase in the column and individual component molecules, each component elutes from the column at distinct retention times, achieving separation.

An appropriate detection and recording system generates a chromatogram displaying the elution time and concentration of each component. Qualitative analysis is performed based on peak retention times and elution order, while quantitative analysis relies on peak height and area.

#### Key Features:

High efficiency

Superior sensitivity

Excellent selectivity

Rapid analysis speed

Broad applicability

User-friendly operation

#### Applications:

Primarily used for qualitative and quantitative analysis of volatile organic compounds. Non-volatile liquids and solids can be analyzed through high-temperature pyrolysis and vaporization. GC may be coupled with infrared absorption spectroscopy or mass spectrometry, using chromatography for complex sample separation to achieve enhanced accuracy.

The working principle is illustrated below:

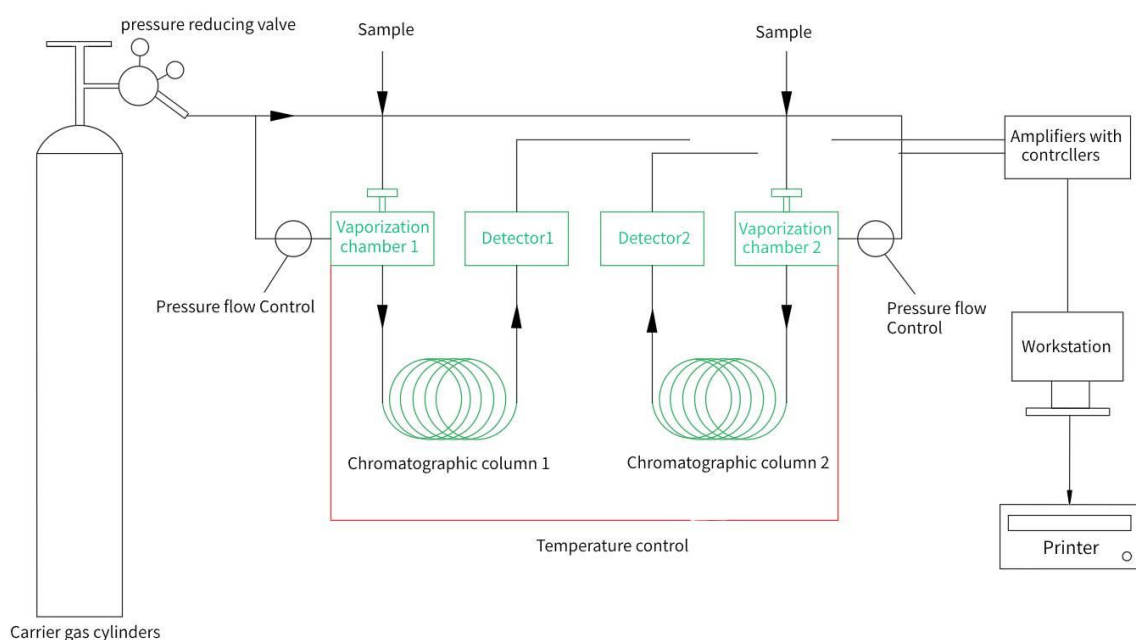

- ① High separation efficiency and rapid analysis speed; for example, over 200 chromatographic peaks can be separated from gasoline samples within two hours, while routine sample analyses are completed within 20 minutes.
- ② Minimal sample consumption and high detection sensitivity; for instance, gas samples require 1 milliliter, liquid samples 0.1 microliters, and solid samples several micrograms. Appropriate detectors can identify impurities at concentrations ranging from tens of parts per million to parts per billion.
- ③ Excellent selectivity, capable of separating and analyzing azeotropic mixtures, substances with similar boiling points, certain isotopes, cis- and trans-isomers, ortho-, meta-, para-isomers, optical isomers, etc.
- ④ Broad application scope; while primarily used for analyzing various gases and volatile organic substances, it can also analyze high-boiling-point materials and solid samples under specific conditions. Key application fields include petroleum industry, environmental protection, clinical chemistry, pharmacology, and food industry.

Consequently, it is extensively applied in petrochemicals, biochemistry, medical and health services, port health quarantine, food inspection, environmental protection, food manufacturing, and clinical medicine sectors. Gas chromatography addresses critical challenges in these fields, including quality inspection of industrial intermediates and products, scientific research, public hazard detection, and production control.

### 1.3 Instrument Features

Leveraging decades of production and R&D expertise, our company has adopted cutting-edge industrial design to integrate mainstream network communication technologies into gas chromatographs, developing next-generation instruments with state-of-the-art international technology. The equipment utilizes the latest highly integrated industrial-grade chips, micro-flow gas control technology, and wide-range I/V dynamic conversion technology, optimizing temperature and gas pressure/flow control precision while enhancing signal acquisition and amplification accuracy—fundamentally elevating instrument reliability and accuracy. Simultaneously, by incorporating fieldbus technology, Ethernet, IoT solutions, and smart data processing systems, it achieves full automation and intelligent operation for user-friendly functionality.

#### **Elite GC2022 gas chromatograph features:**

★ Featuring advanced 100M/1000M Ethernet interfaces with built-in IP protocol stacks, the instrument seamlessly integrates into corporate LANs for workstation connectivity. This design

simplifies laboratory setup and configuration while enabling effortless data management. Users can transfer data, monitor instrument status in real-time via LAN without complex settings, significantly enhancing lab efficiency and data accuracy.

★ Utilizing cutting-edge IoT technology, it enables networked instrument and data management, streamlining monitoring, configuration, maintenance, and data collection/processing/analysis. This approach boosts instrument utilization and data precision while enhancing system flexibility and scalability, laying foundations for remote monitoring, intelligent decision-making, and deep data mining.

★ Equipped with a 7-inch high-definition capacitive touchscreen, it delivers exceptional operational convenience through its well-designed interface and intuitively simple UI.

★ The instrument offers a wide selection of high-performance detectors, including FID, TCD, ECD, FPD, NPD, HID, and PDECD, providing flexible options to meet diverse analytical needs. Notably, it supports the simultaneous installation of up to four detectors—a significant advantage for comprehensive and accurate multi-component analysis of complex samples, enhancing experimental efficiency and accuracy.

★ Featuring a modular structural design, the instrument ensures exceptionally simple and convenient maintenance. Independent and easily detachable modules allow quick identification and efficient handling of routine inspection, cleaning, or fault replacement/repairs, significantly reducing maintenance difficulty and time costs while ensuring long-term stable operation.

★ Equipped with a new microcomputer temperature control system, it delivers stable and precise temperature management through exceptional control accuracy, high reliability, and outstanding anti-interference performance. The system provides eight fully independent temperature control channels and supports flexible programmable temperature ramping up to 99 stages (customizable for expansion), meeting fine-grained temperature requirements for complex experiments. The column oven's automatic back-venting system further enhances near-ambient temperature control, dramatically accelerating heating/cooling rates and improving experimental efficiency.

★ The standard workstation exhibits exceptional compatibility and flexibility, fully supporting mainstream Microsoft OS while incorporating dedicated compatibility with domestic operating systems to meet urgent localization demands. It extends support to Android tablets and other platforms, enabling efficient, stable data processing and analysis across both traditional computers and portable devices, delivering unprecedented convenience and

versatility.

★ With entirely independent intellectual property rights, the chromatograph's microcomputer system integrates the standard MODBUS/TCP protocol for broad device compatibility and specifically supports advanced protocols (e.g., HTTP, MQTT). This enables seamless integration with management platforms, DCS, LIMS, and other systems for effortless data transfer and sharing.

## 1.4 Technical Specifications

### 1.4.1 Main Technical Parameters

- Operation Display: 7-inch high-definition capacitive touchscreen
- Temperature Control Zones: 8 channels
- Temperature Range: Ambient +5° C to 450° C; Increment: 0.01° C; Accuracy: ±0.01° C
- Programmable Temperature Stages: 99 stages (expandable to 999 stages)
- Maximum Ramp Rate: 120° C/min
- Gas Path Control: Precision electronic pressure/flow control
- Gas Control Modes: Constant flow, constant pressure, constant linear velocity, programmed flow, programmed pressure, programmed linear velocity
- EPC Modules: Supports up to 18 channels
- External Events: Up to 12 channels; Auxiliary control outputs: 2 channels; Inputs: 4 channels
- Inlet Types: Packed column, capillary, 6-port gas valve, auto-sampler
- Detectors: Optional FID, TCD, ECD, FPD, NPD, HID
- Sample Initiation: Manual or automatic option
- Communication Interfaces: Ethernet IEEE 802.3, Wi-Fi, built-in instrument hotspot

### 1.4.2 Detector Technical Parameters

#### (1) Flame Ionization Detector (FID)

- Detection Limit:  $\leq 1.1 \times 10^{-12}$  g/s (hexadecane/isooctane)
- Baseline Noise:  $\leq 2 \times 10^{-14}$  A
- Baseline Drift:  $\leq 2 \times 10^{-13}$  A/30min
- Linear Range:  $\geq 10^7$

**(2) Thermal Conductivity Detector (TCD)**

- Sensitivity:  $S \geq 12,000$  mV·mL/mg (benzene/toluene)
- Baseline Noise:  $\leq 0.05$  mV
- Baseline Drift:  $\leq 0.2$  mV/30min
- Linear Range:  $\geq 10^5$

**(3) Electron Capture Detector (ECD)**

- Detection Limit:  $\leq 1.0 \times 10^{-14}$  g/mL ( $\gamma$ -HCH in isooctane)
- Baseline Noise:  $\leq 0.03$  mV
- Baseline Drift:  $\leq 0.2$  mV/30min
- Linear Range:  $\geq 10^4$
- Radioactive Source:  $^{63}\text{Ni}$

**(4) Flame Photometric Detector (FPD)**

- Detection Limit: (S)  $\leq 8 \times 10^{-12}$  g/s, (P)  $\leq 8 \times 10^{-14}$  g/s (methyl parathion in ethanol)
- Baseline Noise:  $\leq 3 \times 10^{-13}$  A
- Baseline Drift:  $\leq 2 \times 10^{-12}$  A/30min
- Linear Range: Sulfur  $\geq 10^2$ , Phosphorus  $\geq 10^3$

**(5) Nitrogen Phosphorus Detector (NPD)**

- Detection Limit: (N)  $\leq 1.0 \times 10^{-12}$  g(N)/s (azobenzene), (P)  $\leq 5.0 \times 10^{-13}$  g(P)/s (methyl parathion in ethanol)
- Baseline Noise:  $\leq 5 \times 10^{-13}$  A
- Baseline Drift:  $\leq 2 \times 10^{-12}$  A/30min
- Linear Range: Nitrogen  $\geq 10^3$ , Phosphorus  $\geq 10^3$

## 1.5 Main Configuration

The Elite GC2022 Gas Chromatograph comprises a carrier gas system, injection system, column system, detection system, temperature control system, data processing and recording system, and auxiliary equipment.

### 1.5.1 Carrier Gas System

The Elite GC2022 employs an Electronic Pressure and Flow Control (EPC) system, offering key advantages:

**High-precision control:** Enables accurate regulation of carrier and auxiliary gas flow rates, enhancing analytical accuracy and repeatability;

**Full automation:** Seamlessly integrated with the microcomputer system for automated gas path adjustment, streamlining operations;

**Exceptional stability:** Rapid response to gas path fluctuations maintains setpoint stability, minimizing analytical interference;

**Operational flexibility:** Supports multiple control modes to accommodate diverse analytical needs, with easy upgradability and maintenance;

**Optimized separation/detection:** Precise carrier gas flow control improves chromatographic separation and detection sensitivity.

### 1.5.2 Injection System

Mounted at the top-left front of the column oven, the injection system features both capillary and packed column inlets:

**Capillary inlet:** Ideal for complex samples, trace component analysis, and high-sensitivity applications due to its high separation efficiency, low column capacity, and rapid analysis speed. Structure as shown:

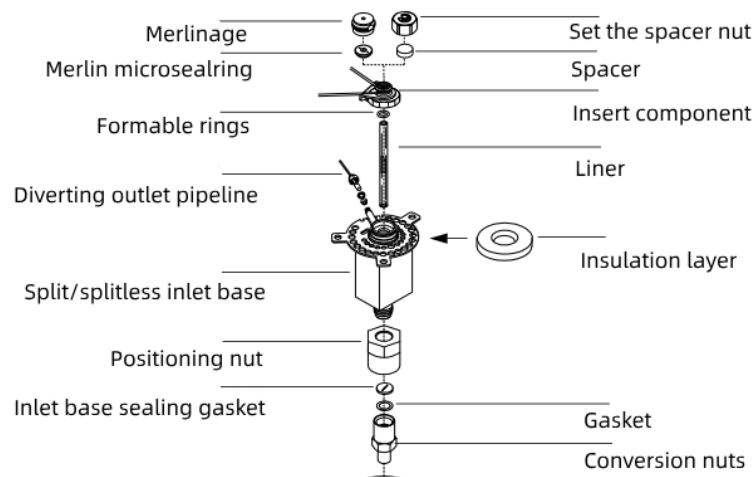

**Packed column inlet:** Packed columns feature large column capacity and high sample loading capability, making them suitable for bulk sample analysis, non-polar compound separation, and routine analytical tasks, as shown:

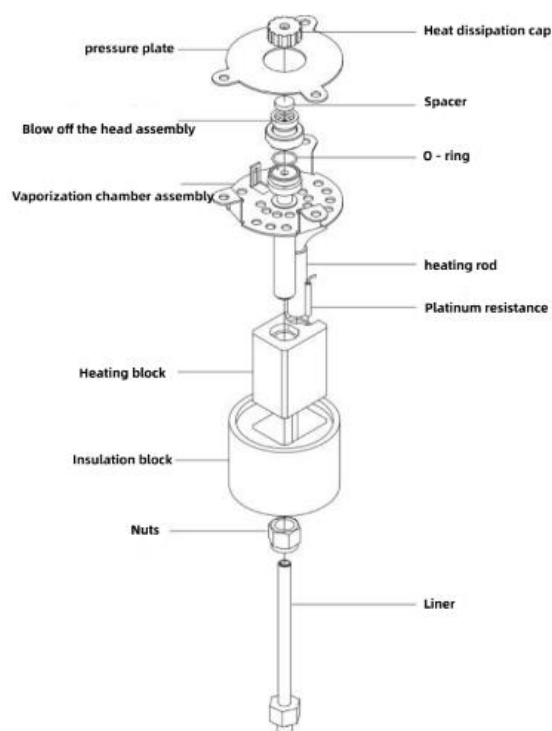

#### Notes:

1. The Elite GC2022 series gas chromatographs support multiple inlets, allowing simultaneous installation of both packed and capillary column inlets;
2. Direct installation of packed columns with  $\Phi 4\text{mm}$  outer diameter is supported; packed columns with  $\Phi 3\text{mm}$  outer diameter can be installed using liners;
3. Dedicated capillary diaphragm purge split/splitless inlets enable split/splitless capillary injection (maximum of 2 simultaneously).

### 1.5.3 Column System

The Elite GC2022 series excels in column oven design with these features:

Large-volume oven: Dimensions 328\*340\*340 (mm) accommodate packed/capillary columns of various sizes, enhancing flexibility;

Rapid temperature ramping: High-power heating wires combined with intelligent auto-opening back door and dedicated fans ensure swift heating/cooling to setpoints;

Dual software temperature protection: Safeguards columns within set temperature ranges, preventing damage and ensuring stability;

Low-noise thermal mixing: Utilizes silent motors and stainless-steel fan blades for quiet operation, reducing environmental interference.

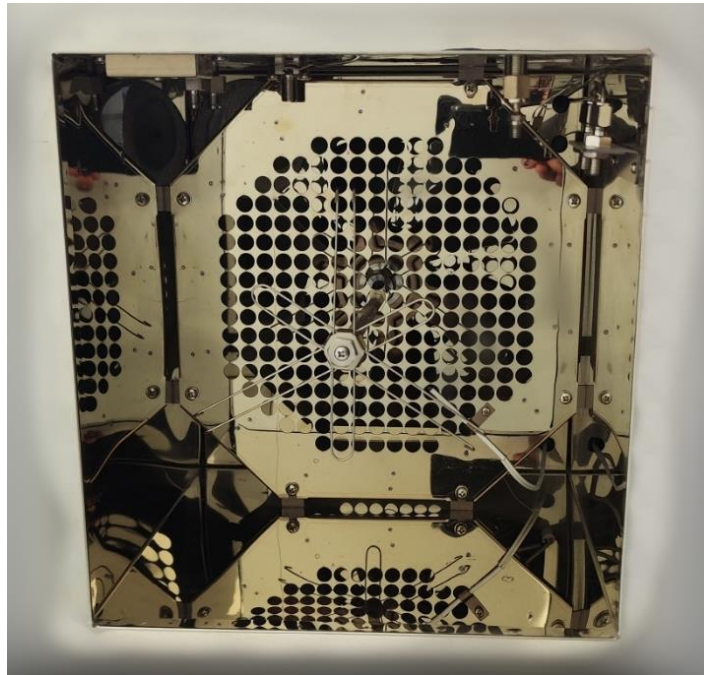

### 1.5.4 Detection System

#### 1. Flame Ionization Detector (FID)

The FID, a mass-sensitive detector, features high sensitivity, wide linear range, operational condition insensitivity, and excellent stability. Ideal for routine macro/micro analysis, its fast response enables rapid trace analysis with capillary columns—making it the most widely used GC detector.

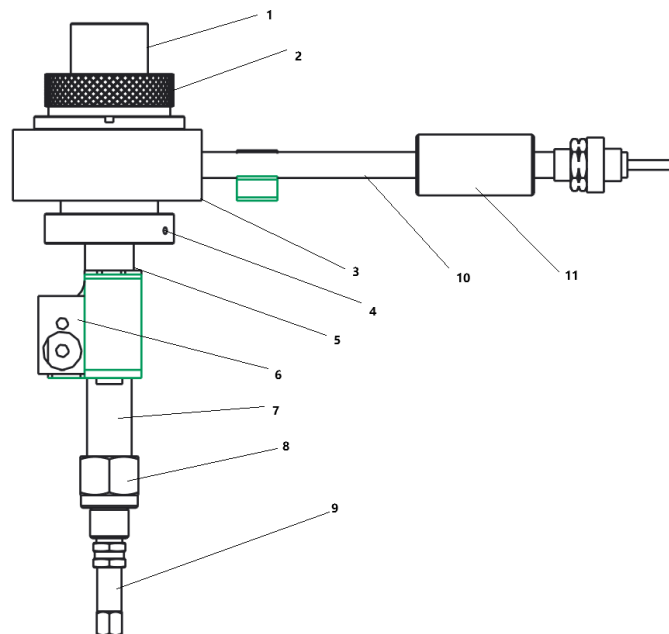

- 1 Ignition wire 2 Fixing nut 3 Ion chamber base 4 Air inlet 5 Hydrogen inlet 6 Heating block 7 base  
8 Adapter nut 9 Column nut 10 Signal tube 11 Magnetic ring

Mounted at the top-right of the main unit, the FID base sits within a thermal block containing heating elements and temperature sensors connected to the temperature control system. A polarization voltage between the signal terminal and detector body creates an electric field. Signals from the collector travel via insulated signal tubes to the amplifier. Hydrogen/air enter through stainless-steel tubing connected to the gas control system above the main unit. Operating principle: Samples combust in a hydrogen flame, generating ion currents. Polarized ions move directionally under the electric field toward the collector, producing weak current signals amplified by a microcurrent amplifier before transmission to the chromatography data system.

**Gas Source Management:**

- DO NOT open hydrogen flow before column installation to prevent hydrogen accumulation in the column oven—critical for avoiding explosion hazards.
- During shutdown: First cut hydrogen/air supply to extinguish the FID and allow cooling, THEN shut off carrier gas—ensuring safe deactivation and preventing equipment damage.
- This high-sensitivity detector REQUIRES purified high-purity carrier gas, hydrogen, and air; impurities compromise accuracy and performance.

**Column Aging & Detector Protection:**

- During column aging: Disconnect the column from the detector and seal the detector port with a nut to prevent contamination.
- When aging with hydrogen: Safely vent column outlet hydrogen to designated areas to eliminate accumulation risks.

**Electrical Safety:**

- Before power-on: Verify circuit integrity and gas compatibility with instrument specifications—essential for safe operation.
- During operation: The collector carries LETHAL 200V HIGH VOLTAGE. Strictly adhere to safety protocols and avoid contact.

**2. Thermal Conductivity Detector (TCD)**

The Elite GC2022 series supports optional Thermal Conductivity Detector (TCD). Structure as shown:

-

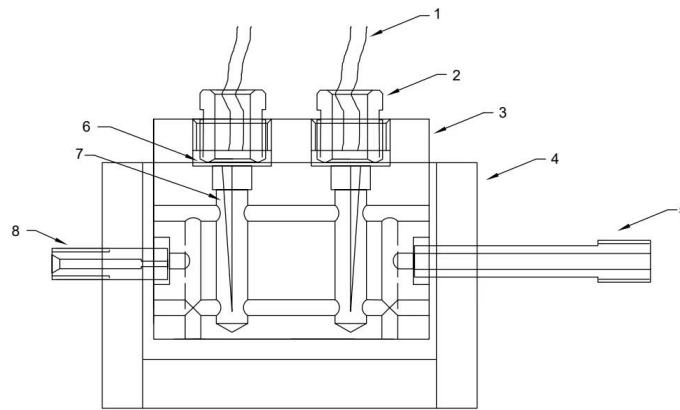

1 Tungsten filament leads 2 Compression nuts 3 Cavity 4 Heating block 5 Outlet fitting 6 Copper gasket 7 Tungsten filament 8 Inlet fitting

The TCD comprises a thermal conductivity cell and detection circuitry. The cell houses thermosensitive elements (e.g., tungsten/platinum filaments) configured in a Wheatstone bridge. The cell body—a metal block with precision-machined cavities and channels—holds these elements while allowing carrier gas flow.

### Operating Principle

Based on thermal conductivity variations between gases:

Carrier gas flowing through the cell carries heat away from heated filaments.

Sample gas entering the cell alters the mixture's thermal conductivity.

Changed heat dissipation modifies filament temperature and resistance.

Bridge imbalance generates voltage signals proportional to conductivity changes.

Signal analysis determines sample composition/concentration.

### Fundamental Operating Principles

Gas Flow → Temperature Ramp → Current Activation:

When operating the TCD detector, carrier gas **MUST** be purged first to ensure unobstructed gas path and stable flow **BEFORE** initiating heating. Bridge current should **ONLY** be set **AFTER** the detector temperature stabilizes. This sequence prevents thermosensitive elements (e.g., tungsten filaments) from damage due to direct heating without carrier gas protection.

### Shutdown Sequence:

Deactivate bridge current **FIRST** to allow gradual cooling under carrier gas protection.

Shut off carrier gas **ONLY** when TCD temperature drops to approximately 50°C below ambient temperature. This practice safeguards thermosensitive elements against thermal shock, extending service life.

### Current and Carrier Gas Management

Current Settings: **STRICTLY AVOID** excessive bridge currents during operation. High currents

accelerate tungsten filament oxidation, degrading detector sensitivity and longevity. Optimize

bridge current based on:

Carrier gas type

Detector temperature

Sample characteristics

(Refer to diagram for carrier gas/temperature/bridge current correlations)

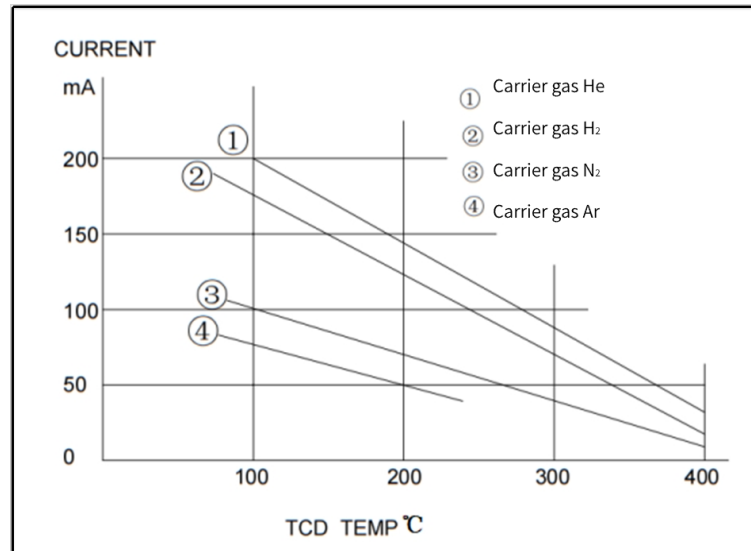

#### Carrier Gas Selection & Purification:

The type and purity of carrier gas critically impact TCD performance. Typically, inert gases with high thermal conductivity (e.g., helium or hydrogen) are selected. Carrier gas **MUST** undergo thorough purification to remove impurities like oxygen and moisture, preventing damage to thermosensitive elements.

#### Bridge Current Setting & Retention:

To prevent TCD damage from operational errors, many instruments feature non-retention of bridge current settings after shutdown. Upon each startup, TCD bridge current resets to zero, requiring user reconfiguration. This design minimizes equipment damage risks from mishandling.

#### Safety Warnings

Oxygen Removal from Carrier Gas:

Oxygen presence accelerates oxidation of TCD tungsten filaments, drastically reducing lifespan.

Therefore, carrier gas **MUST** be rigorously deoxygenated before TCD operation.

### 3. Electron Capture Detector (ECD)

The Electron Capture Detector (ECD), another ionization-type detector, offers selective high sensitivity. It responds **ONLY** to electronegative substances (e.g., halogen-, sulfur-, phosphorus-, or nitrogen-containing compounds). Detector sensitivity increases with stronger electronegativity

(higher electron absorption coefficient), whereas electrically neutral substances (e.g., alkanes) produce no signal.

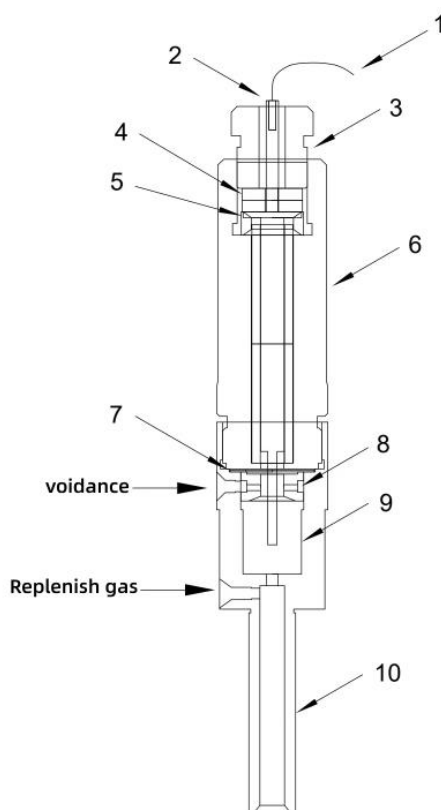

1 Signal lead; 2. Electrode; 3. Electrode compression cap; 4. Insulating PTFE gasket I; 5. Insulating PTFE gasket II; 6. Upper base; 7. Sealing gasket; 8. Purge septum; 9. Nickel-63 source; 10. Lower base.

The ECD detection cell contains a sealed radioactive source (Ni-63) that emits  $\beta$  radiation. This radiation ionizes the inert carrier gas (typically  $N_2$ ) within the cell. A pulsed voltage is applied to the collector electrode, generating a baseline current through electron capture. When an electronegative analyte molecule enters the detection cell, it captures free electrons, forming negative ions. These charged molecules exhibit slower migration velocity compared to free electrons, resulting in prolonged travel time to the positive electrode and increased recombination probability with positive ions. Consequently, the electron density within the detector decreases, reducing the number of electrons captured per pulse. To maintain a constant current per unit time, the system compensates by increasing the pulse frequency. The resultant pulse count variation correlates directly with the concentration of electronegative analyte molecules.

The schematic diagram of the ECD device is as follows:

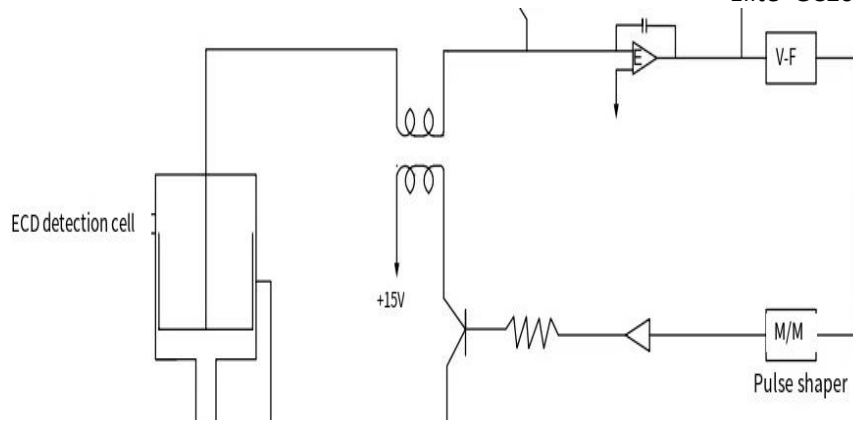

The amplifier (E) compares the preset current ( $I_R$ ) with the average pulse current generated by the ECD detection cell. The voltage required to equalize these two values is fed into the subsequent voltage-to-frequency converter (VFC). After the VFC conditions the pulses to appropriate amplitude and height, the output signals are routed back to the ECD detection cell, forming a closed-loop control circuit.

**Warning:**

**Unauthorized Disassembly Prohibited:** Disassembly of the ECD detector without professional radiation safety measures is strictly prohibited! Exposure to the Ni-63 radioactive source will harm your health.

**Regulated Waste Disposal:** ECD detectors containing Ni-63 are strictly controlled materials and must NOT be discarded as conventional waste.

Our company holds final-user exemption certification for radiation-containing instruments. Purchasers of our Ni-63-equipped instruments are exempt from local environmental bureau licensing requirements for Radiation Safety Permits. However, users must:

Maintain strict usage records for all radiation-containing instruments.

Cooperate with our company's regulatory compliance audits.

Notify us prior to instrument retirement for proper source recovery and filing.

Unauthorized disposal of Ni-63 sources by end-users is strictly prohibited.

#### 4. Flame Photometric Detector (FPD)

The Flame Photometric Detector (FPD) is a gas chromatography detector with high selectivity and sensitivity for phosphorus- and sulfur-containing compounds. During sample combustion in a hydrogen-rich flame:

Phosphorus compounds emit light at 526 nm primarily through HPO fragments

Sulfur compounds emit characteristic light at 394 nm via  $S_2$  molecules

A photomultiplier tube converts these optical signals into electrical signals, which are

Elite GC2022 Gas Chromatograph amplified by a microcurrent amplifier and recorded. This detector achieves sensitivity ranging from tens to hundreds of coulombs per gram (C/g), with a minimum detection limit of  $10^{-11}$  g. Simultaneously, the response ratio for organophosphorus/organosulfur compounds to hydrocarbons can reach  $10^4$ , effectively eliminating interference from solvent peaks and hydrocarbons. These properties make it exceptionally suitable for trace analysis of phosphorus and sulfur, establishing the FPD as a primary tool for detecting organophosphorus pesticides and sulfur-containing pollutants.

As shown in Figure 1.12, the FPD consists of two main components: a flame emission assembly and an optical/electrical signal system.

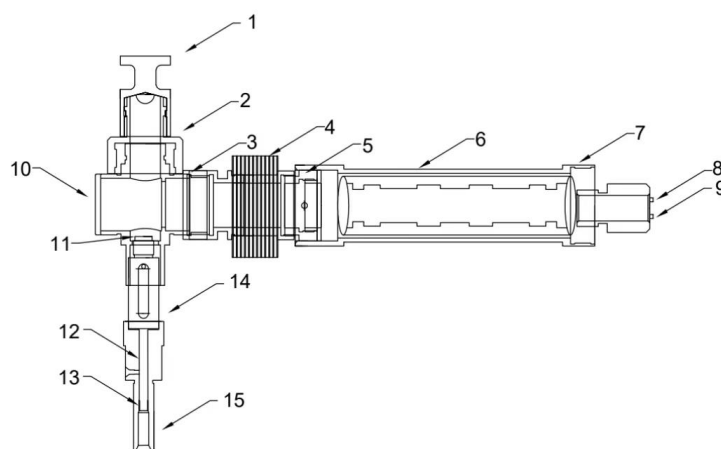

1. Vent joint nut; 2. Vent joint; 3. Optical chamber; 4. Heat sink cylinder; 5. Filter and pressure pad; 6. Photomultiplier tube housing; 7. High-voltage base; 8. Signal output; 9. High-voltage input; 10. Optical window nut; 11. Light shield; 12. Glass liner tube; 13. Set screw; 14. Upper base; 15. Lower base.

The flame luminescence system comprises a burner assembly (combustion head) and a luminous chamber. The burner incorporates gas flow paths and nozzles—the universal nozzle consists of an inner bore and an annular outer orifice. Gas chromatograph column effluent mixes with air in the central bore, while excess hydrogen flows through the surrounding annular orifice. This configuration generates a large, diffusion-rich hydrogen flame where hydrocarbons, sulfur-containing compounds, and phosphorus-containing compounds undergo pyrolysis and complex chemical reactions, emitting characteristic light. Sulfur and phosphorus species luminesce in the upper diffusion flame zone, while hydrocarbons primarily emit light in the oxygen-rich flame zone at the base. An opaque light shield is installed at the flame base to block hydrocarbon emission, enhancing FPD selectivity. To minimize luminous chamber volume, a glass or quartz liner tube may be installed above the nozzle, reducing the detector's response time constant.

The optoelectronic system (right side of diagram) isolates the luminous chamber from the photomultiplier tube assembly using a quartz window and heat sink, preventing adverse effects

from water vapor, combustion byproducts, and high temperatures. Notably, the FPD does not convert all emitted light into electrical signals—a filter selectively transmits sulfur/phosphorus characteristic wavelengths (e.g., 526 nm for  $\text{HPO}^*$  and 394 nm for  $\text{S}_2^*$ ).

Warning: Never activate the high-voltage power supply when the detector has light leaks!

### 1. Nitrogen-phosphorus Detector (NPD)

The Nitrogen-Phosphorus Detector (NPD), also known as the Thermionic Ionization Detector (TID), is a detector characterized by high sensitivity, exceptional selectivity, and a wide linear range for analyzing nitrogen (N)- and phosphorus (P)-containing compounds. In 1961, Cremer et al. initially developed a flame thermionic detector by heating an alkali source above the jet of an FID detector. However, due to the use of volatile alkali metals, this design suffered from short lifespan, unstable detector sensitivity, and no practical value for widespread adoption. In 1974, Kolb utilized non-volatile rubidium carbonate sintered with silicon dioxide to form rubidium silicate beads, overcoming the short lifespan limitation of rubidium beads. Since the beads were electrically heated in a cold hydrogen flame, the detector's stability was significantly enhanced, sensitivity markedly improved, and background baseline current reduced from  $10^{-9}\text{A}$  to  $10^{-13}\text{A}$ . Consequently, the NPD emerged as one of the most commonly equipped detectors in gas chromatographs, becoming a specialized detector for trace-level nitrogen and phosphorus compound analysis, extensively applied in environmental protection, pharmaceuticals, clinical research, biochemistry, food science, and other fields.

The structure and operation of NPD vary across product models, with a typical configuration illustrated in the following diagram.

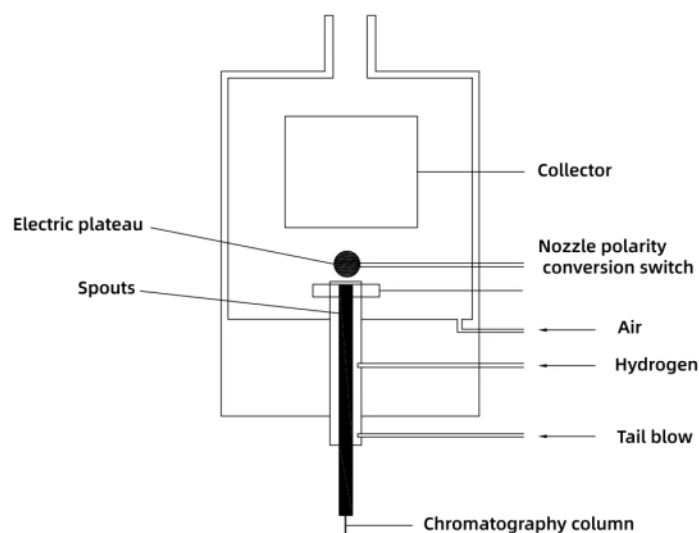

The Elite GC2022 detector operates in nitrogen-phosphorus (NPD) mode, with the nozzle electrically isolated (ungrounded) as illustrated.

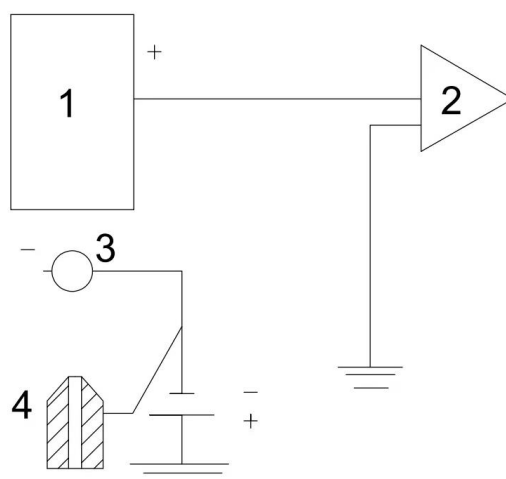

1 Collector | 2 Amplifier | 3 Ionization Source | 4 Nozzle

When air and hydrogen flow rates are low [ $V_{\text{air}} < 150 \text{ mL/min}$ ,  $V_{\text{H}_2} < (4-9 \text{ mL/min})$ ], the electrically heated ionization source reaches incandescence. This forms a cold flame around the source, where nitrogen (N)- and phosphorus (P)-containing organic compounds undergo pyrolysis and excitation. The resulting selective detection for N and P achieves a hydrocarbon selectivity ratio of  $10^2-10^4$ .

### 1.5.5 Temperature Control System

The temperature control circuitry, located inside the right-side chassis, heats the injection system, column system, detection system, and auxiliary components. The gas chromatograph's temperature control system serves the following critical functions:

#### Ensuring Analytical Accuracy:

Temperature is a key parameter for chromatographic separation conditions. Precise control of the vaporization chamber, column oven, and detector temperatures ensures optimal sample separation and detection conditions, thereby enhancing analytical accuracy and reliability.

#### Enhancing Separation Efficiency:

Adsorption interactions between analytes and the stationary phase vary, resulting in distinct retention times. Accurate column temperature control optimizes component separation, enabling peak resolution at their respective ideal temperatures.

#### Protecting Instrument Components:

Stable temperature regulation prevents component damage. For example, excessive detector temperature fluctuations could degrade sensitivity or stability. Precise control ensures detectors operate at optimal temperatures, extending service life.

#### Meeting Diverse Analysis Requirements:

The system supports temperature programming (e.g., isothermal, ramped) to accommodate varied sample matrices, expanding the GC's applicability across multiple fields.

**Operational Principle:**

The system integrates temperature sensors, controllers, and actuators:

**Temperature Sensing:** PT100 platinum resistors are employed, with resistance values increasing proportionally to temperature. Resistance changes are monitored in real time.

**Controller Processing:** Digital signals undergo PID-based computational processing. The controller compares actual and setpoint temperatures, generating corrective control signals.

**Heater Actuation:** Thyristors modulate power delivery to heating elements (e.g., heating rods, wires), enabling precise temperature regulation.

**Intelligent Rear Door Mechanism:** Facilitates rapid heat dissipation by expelling hot air while drawing in cool air, accelerating cooling rates. Adjustable door openings maintain near-ambient temperature stability, critical for volatile compound analysis.

**Note:** The column oven operates at 220 VAC, while all other heating zones use 40 VAC.

---

### 1.5.6 Data Acquisition & Processing System

The chromatography workstation is an auxiliary software platform designed to facilitate signal sampling from chromatographic instruments, collect voltage signals from detectors, and perform comprehensive data analysis and processing. It typically comprises hardware and software components:

**Hardware:** Includes signal acquisition devices (e.g., analog-to-digital converters) that convert analog signals from chromatograph detectors into digital signals processable by computers.

**Software:** Enables functions such as chromatogram visualization, peak detection, baseline correction, quantitative/qualitative analysis, and report generation.

The roles of chromatography workstations are mainly reflected in the following aspects:

**Data Acquisition and Processing**

**Real-Time Acquisition:** Capable of capturing real-time data generated by chromatographs, including chromatograms, peak areas, peak heights, and other critical parameters.

**Data Processing:** Performs analytical tasks such as peak identification, quantitative/qualitative analysis, and calibration to enhance accuracy and reliability of results.

**Data Storage and Management**

**Data Archiving:** Provides storage capabilities for experimental data, enabling researchers to retrieve historical records conveniently.

**Data Organization:** Facilitates categorization, annotation, and of data through integrated management systems, improving operational efficiency.

### **Instrument Control**

**Parameter Configuration:** Allows users to set chromatograph operating parameters (e.g., temperature programs, flow rates) via graphical interfaces.

**Automated Operation:** Advanced workstations support unattended automation by adjusting instrument parameters according to predefined protocols.

### **Result Reporting and Visualization**

**Data Reporting:** Generates analytical reports in graphical or textual formats to facilitate result presentation and dissemination.

**Chromatogram Printing:** Supports hardcopy output of chromatograms for archival or sharing purposes.

### **Network Connectivity and Expandability**

**Network Integration:** Enables connectivity to IoT platforms for data sharing and remote instrument control.

**Expandability:** Interfaces with ancillary devices (e.g., mass spectrometers) or software tools to extend functional scope.

### **Experimental Design and Optimization Support**

**Method Development:** Assists in optimizing chromatographic conditions by providing analytical tools and historical data comparisons.

**Diagnostic Capabilities:** Monitors instrument status through self-diagnostic functions, enabling proactive fault detection and resolution to ensure experimental continuity.

---

## **1.5.7 Auxiliary equipment**

### **Display Screen**

Elite GC2022 Series Chromatographs feature a 7-inch capacitive touchscreen that significantly enhances user experience. The high-resolution display with responsive touch control enables intuitive and clear monitoring of instrument status and parameters.

The thoughtfully crafted touchscreen interface is both concise and lucid. Logically organized functional zones with clearly visible icons and menu items allow users to swiftly locate and operate desired functions. Both novice and experienced users can master instrument operation

Elite GC2022 Gas Chromatograph efficiently. Configuration adjustments, real-time data monitoring, and data processing/analysis are seamlessly performed via the touchscreen. This integrated design boosts workflow efficiency while simplifying experimental procedures.

For specific operation methods, refer to Chapter 3 of the chromatograph's operation manual.

#### External Event Control

External event controls for the Elite GC2022 Series GC are internally managed, with primary I/O connections routed to rear-panel sockets. Wiring definitions are as follows:

Black: Common terminal (GND)

Red: Instrument ready status output (24VDC)

Yellow: Start analysis input (short-circuit to GND)

#### Instrument Communication

The instrument employs a 10/100/1000 Mbps auto-sensing Ethernet interface, connecting to workstation computers via LAN cable or wireless Wi-Fi. To ensure high resolution and stability, a 24-bit AD circuit is integrated internally. Conventional analog signals are no longer output, and the instrument connects exclusively with our proprietary workstations.

## 1.6 Instrument Operating Environment

### 1.6.1 Installation Environment

**Temperature and Humidity:** Optimal operating temperature range is 5–35°C with 0–85% relative humidity. To maximize instrument performance and extend its operational lifespan, use in human-comfort environments with stable temperature and humidity conditions.

**Corrosive Substances:** Avoid exposing the instrument to corrosive materials (gases, liquids, or solids) that may compromise structural components.

**Workbench Stability:** The bench mounting the Elite GC2022 GC must be sturdy to prevent vibration-induced instability.

**Clearance Requirements:** Maintain  $\geq 30$ cm rear clearance for column oven heat dissipation. Flammable materials must not be placed behind the instrument. Additionally, reserve 30–40cm access space for installation and maintenance.

**Network Interface:** Requires 10/100M or Gigabit Ethernet port. Connect via HUBs or switches to establish Ethernet communication.

Adherence to these conditions ensures optimal performance and long-term stability of the Elite GC2022.

### 1.6.2 Power Supply Environment

**Voltage and Frequency:** The Elite GC2022 gas chromatograph requires an input power supply of 220V  $\pm$ 10% at 50Hz  $\pm$ 0.5Hz. This specification ensures stable instrument operation and prevents performance degradation or instability caused by power fluctuations.

**Power Rating:** The electrical supply must deliver a minimum power capacity of 2500W to adequately support all operational functions during instrument runtime.

**Grounding Standards:** To ensure operator safety and minimize electrical noise, the instrument's panel and chassis must be grounded in compliance with International Electrotechnical Commission (IEC) regulations using a three-core power cord for reliable earthing.

Prohibited: Substitution of grounding lines with water pipes, gas pipes, or neutral wires is strictly forbidden. These alternatives fail to meet safety requirements and pose significant hazards.

Note: While no explicit ground resistance value is specified, effectiveness typically requires maintaining resistance below 1 $\Omega$  (per IEC 60364 standards) to ensure safety compliance.

#### Importance of Grounding:

- **Safety Protection:** Proper grounding prevents electric shock hazards arising from electrical faults or static discharge.
- **Noise Mitigation:** Grounding reduces electrical noise, enhancing measurement accuracy and operational stability.

**Conclusion:** Strict adherence to these power supply and grounding specifications is mandatory to ensure safe, reliable, and high-performance operation of the Elite GC2022 gas chromatograph.

### 1.6.3 Gas Supply Requirements

To optimize the performance of the Elite GC2022 gas chromatograph, gases must meet specified purity standards. Recommended purities are as follows:

Detector	Gas Function	Gas Name	Purity
FID	Carrier	N <sub>2</sub> or He	$\geq$ 99.999%
TCD	Carrier	He, H <sub>2</sub> , or N <sub>2</sub>	$\geq$ 99.999%
ECD	Carrier	N <sub>2</sub>	$\geq$ 99.999% (deoxygenated)
NPD	Carrier	N <sub>2</sub> or He	$\geq$ 99.999%
FPD	Carrier	N <sub>2</sub> or He	$\geq$ 99.999%

FPD	Makeup	N <sub>2</sub>	≥99.99%
FPD	Fuel	H <sub>2</sub>	≥99.99%
FPD	Auxiliary	Air	Clean and dry

We recommend installing gas purifiers in the gas supply lines! After prolonged use, the molecular sieves and silica gel within these purifiers must undergo activation treatment to restore their purification capacity.

## 2 Instrument Installation

### 2.2 Unpacking the Instrument

Upon receipt of the instrument, immediately inspect the exterior packaging for damage. If any damage is observed, contact the manufacturer or supplier promptly. After unpacking, carefully verify all included components against the packing list to ensure completeness. In the event of missing parts or physical damage to the instrument, promptly notify the manufacturer or supplier to prevent financial loss or operational delays.

### 2.2 Instrument Installation

After verification, place the instrument on a stable workbench. The workbench must be rigid. Avoid storing flammable materials behind the instrument and ensure adequate space for maintenance access.

#### 2.2.1 Gas Source Installation

Prior to operating the Elite GC2022 gas chromatograph, be sure to follow the preparation steps outlined in Section 1.5. Select an appropriate detector based on your analytical requirements and equip it with a compatible gas source.

The gas source must be installed in a safe location. If using gas cylinders, securely fasten them to prevent tipping hazards.

Regardless of gas source type (e.g., gas generator, cylinder, or air compressor), rigorously verify gas quality parameters (e.g., purity, stability) to ensure compliance with the stringent requirements of the Elite GC2022 gas chromatograph. Substandard gas sources not only directly compromise the accuracy of analytical results but may also contaminate the instrument or cause irreversible damage.

#### 2.2.2 Pressure Reducing Valve Installation

##### Preparation of Pressure Reducing Valves and Fittings:

First, gently unscrew the low-pressure outlet heads from two oxygen pressure reducing valves and one hydrogen pressure reducing valve.

Next, attach the pressure reducing valve adapters to the low-pressure outlets of all three valves. Install the low-pressure output adjustment rod without tightening it fully—leave some clearance for adjustment.

### Installation of Pressure Reducing Valves to Cylinder:

Align the prepared pressure reducing valves with the cylinder's valve outlet, then gently screw on and tighten the nuts to ensure a tight connection between the valves and the cylinder.

Open the cylinder's high-pressure valve; at this point, the high-pressure gauge on the valve should display pressure readings, indicating the gas pressure inside the cylinder.

### Leak Check for Pressure Reducing Valves:

After confirming the valves are properly installed and connected, close the cylinder's high-pressure valve.

Observe the high-pressure gauge—its indicated value must remain stable without any decrease.

If the gauge reading drops, it indicates a leak at the pressure reducing valve or connections. Immediately discontinue use and thoroughly inspect to identify and resolve the leak source.

### Completion of Installation and Preparation for Use:

Once leak-free operation is confirmed, adjust the low-pressure output adjustment rod as needed to set the required gas pressure.

Ensure all connections are securely fastened without looseness, then power on the gas chromatograph for subsequent operations.

## 2.2.3 Installation of external gas lines

The Elite GC2022 gas chromatograph uses polyethylene, PTFE, stainless steel, or copper tubes with an outer diameter of  $\Phi 3 \times 0.5$  for external gas line connections.

The connection method is illustrated in the figure below:

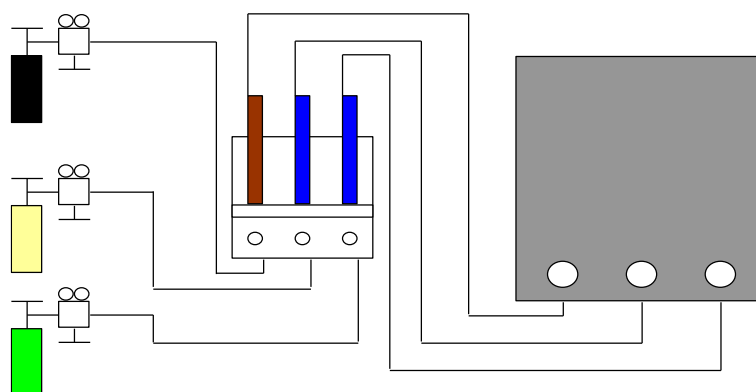

### Note:

1. Exhaust ports for gas circuit splitting and detector vents must be connected to outdoor piping to prevent indoor air pollution when analyzing toxic or harmful substances.
2. During operation, regularly check for leaks! Even minor leaks may impair instrument

function, while severe leaks (e.g., hydrogen leakage) could cause accidents such as explosions.

3. Carrier gas inlet pressure to the chromatograph: 0.5 MPa.
4. Air inlet pressure to the chromatograph: 0.5 MPa.
5. Hydrogen gas inlet pressure to the chromatograph: 0.4 MPa.

---

#### **2.2.4 System Leak Check**

After completing the gas line installation, perform a leak check to prevent accidents. Follow the steps below:

(1) Power off the main unit.

(2) Set the cylinder's low-pressure adjustment rod to the relaxed position, open the cylinder's high-pressure valve, then slowly adjust the low-pressure adjustment rod to achieve the following pressures on the low-pressure gauge:

Carrier gas cylinder: 0.5 MPa

Hydrogen gas cylinder: 0.4 MPa

Air cylinder: 0.5 MPa

(If using a gas generator, follow the pressure indication when the generator stops operating.)

(3) Close the cylinder's high-pressure valve and shut off the carrier gas, hydrogen, air, makeup gas, split flow, and purge valves on the chromatograph. Set the cylinder's low-pressure adjustment rod to the relaxed position. Monitor the pressure gauge for any pressure drop. If the pressure remains stable for 10 minutes, the system is leak-free. If the pressure drops, a leak exists in the gas circuit; inspect and repair segment by segment until resolved.

## 3 Operation of the Chromatograph

The Elite GC2022 gas chromatograph is equipped with a 7-inch color LCD screen featuring a flat design interface. It provides a comprehensive instrument status overview, enabling users to grasp the operational state at a glance, while also allowing detailed parameter configuration. With its full functionality, well-organized layout, and intuitive operation, users can thoroughly understand and operate this high-performance chromatographic analysis device.

### 3.1 Startup Interface

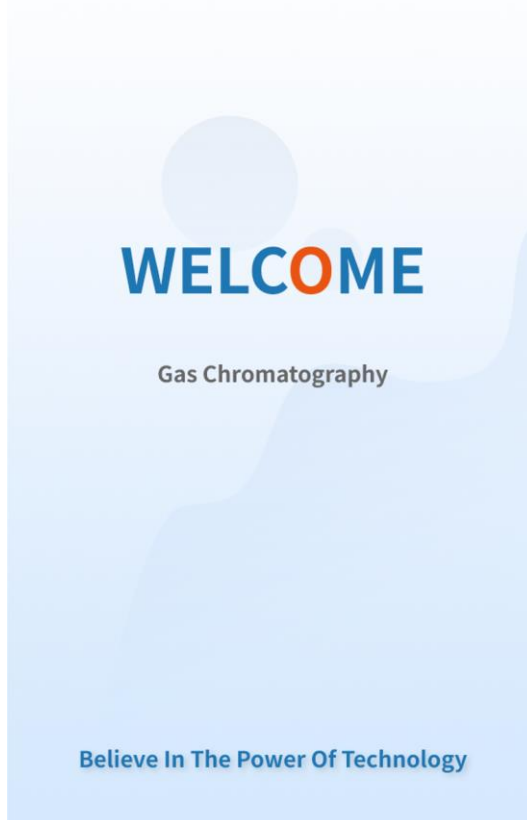

Upon powering on the instrument, the display shows the startup interface (as shown above).

### 3.2 Homepage

Tap the startup interface to enter the instrument's main interface, where the overall operational status can be monitored (as shown below):

2024-02-27 16:18

HOME
CHAN
STATE
GRAPH

HOME

	INJ1	COLUMN	FID1
Chn A			
	220.00°C	120.02°C	260.01°C
	14.500psi	1.000sccm	3.141pA

	INJ2	COLUMN	FID1
Chn B			
	160.00°C	120.02°C	260.01°C
	14.500psi	1.200sccm	16.021pA

	INJ3	COLUMN	TCD
Chn C			
	0°C	120.02°C	0°C
	0psi	0sccm	0mV

METH  
DIAG  
MAINT  
LOG  
SET  
HELP

STATE : READY
▲

Method : 123.da

Change A time : 0.067min

Change B time : 25.0min

Change C Running

STOP

ANALY

2024-02-27 16:18

HOME
CHAN
STATE
GRAPH

HOME

NO.	Parameters	SV	RV
1	StandbyDisabled	0°C	0°C
2	Oven	200°C	200°C
3	Inj1	250°C	250.02°C
4	Dec1	280°C	279.98°C
5	Inj2	200°C	199.99°C
6	Dec2	250°C	250°C
7	Inj3Disabled	0°C	0°C
8	Dec3Disabled	0°C	0°C

METH  
DIAG  
MAINT  
LOG  
SET  
HELP

Waiting
▼

Method : 123.da

Change A time : 0.067min

Change B time : 25.0min

Change C Running

Stop

ANALY



**Left navigation area:** Used for switching pages, it is divided into seven pages: Home Page, Parameter, Diagnostics, Maintenance, Logs, System Settings, and Help.

The home page is divided into three interfaces: Flow Path, Status, and Curve, which can be switched using the buttons located above.

**Flow Path:** Displays the main operational status of each channel, including inlet temperature, carrier gas pressure, column oven temperature, column flow rate, detector temperature, detector status, detector real-time signal, etc.

Different icons in the detector area represent different detectors and their statuses, as described below:



FID (Not ignited/ignited)



TCD (without bridging/with bridging)





FPD (Without high voltage/with high voltage)



NPD (Unactivated/activated)



ECD (Unbase stream/base Stream)

-  Zirconia (unheated/heated)
-  HID (Unpressurized/pressurized)
-  PDECD (No high voltage/High voltage)

**Status:** Used to display other parameters.

**Curve:** Used to display real-time plots generated from detector signals, with options to select displayed signals via checkboxes.

**Lower control area:** Displays instrument operational status, temperature control, and analysis controls.

The status bar uses three colors to indicate:

**Yellow** — Unready

**Green** — Ready

**Red** — Alarm

## 3.3 Methods

Clicking "PARA" on the left navigation bar opens the method parameters interface, which is further categorized into: Inlet, Column, Oven, Detector, Time, Auxiliary Heating, and Method Files.

### 3.3.1 Injection port

The inlet is categorized into capillary and packed column types. Inlet parameters are shown in the figure below:

2024-02-27 16:18

Option Inj CC Oven Dec Event Aux

Inj1 Inj2 Inj3

HOME

Heat Control

Enable SV(°C) : 250.00 PV(°C) : 250.01

PARAM

DIAG

MAINT

LOG

SYS

HELP

Gas Control

Split Type: Split

Carr-gas Mode: Press

Carr-gas Type: N2

Non-Split(S): 0

GAS	SV	PV
Carr-gas Press(psi):	14.500	14.500
Carr-gas Flow(sccm):	0	2.12
Carr-gas Speed(cm/s):	0	50
Split Ratio(N:1):	25	25
Split(sccm):	50.000	50.000
Purge(sccm):	4.00	4.00
Aux flow(sccm):	4.00	4.00

Pulse Press(psi)  Pulse Time(min)

Carr-gas Saving Saving Flow(ml/min)  After(min)

Programed Flow

Enable

NO.	Slope (sccm/min)	Final (sccm)	Keep (min)
1	--	--	0
2	0	0	0
3	0	0	0
4	0	0	0
5	0	0	0

READY

Method : 123.da

Change A time : 25.0min

Change B time : 25.0min

Change C Running

Stop Finish

Heat control:

Enable ---- Turn on the heating function

SV---- Target temperature for heating.

PV ---- Real-time temperature value

Gas Control:

Split type: Options include Split, Splitless, Pulse Split, and Pulse Splitless.

Carrier-gas Mode: Modes include Pressure Control, Flow Control, and Linear Velocity Control.

After selecting the control type, input parameters in the corresponding setpoint field on the right.

Carrier-gas Type: Select the correct gas type to ensure accurate column flow calculations.

Channel: Configure the injection port into the corresponding channel.

Non-Split: The time to adjust the split flow rate when the non-split mode is selected.

Split ratio: Set either the split ratio or split flow, and the system will automatically calculate and adjust the flow.

Purge: Septum purging flow.

Aux press: When using a dual-channel carrier gas EPC, this item is the second channel carrier gas flow.

### 3.3.2 Chromatographic column

Click the navigation key "CC" above to bring the instrument into the chromatographic column parameters interface, as shown below:

2024-02-27 16:18

Option Inj **CC** Oven Dec Event Aux

HOME

PARA

DIAG

MAINT

LOG

SYS

HELP

Inj1

Column Name :

Column Type :

Length(m) :  Inner diameter(um) :

Film thickness(um) :

Inj2

Column Name :

Column Type :

Length(m) :  Inner diameter(um) :

Film thickness(um) :

Inj3

Column Name :

Column Type :

Length(m) :  Inner diameter(um) :

Film thickness(um) :

READY

Method : 123.da

Change A time : 25.0min

Change B time : 25.0min

Change C Running

Stop Finish

This interface allows setting column parameters, including: film thickness, length, inner diameter, and maximum temperature. Additional columns can be downloaded from the column library via the workstation software.

### 3.3.3 Column oven

Click the navigation button "Oven" above to enter the instrument into the column oven parameter interface:

The screenshot displays the 'Heat Control' settings for the Elite GC2022 Gas Chromatograph. The interface includes a navigation menu on the left with options: HOME, PARA, DIAG, MAINT, LOG, SYS, and HELP. The top navigation bar shows 'Option', 'Inj', 'CC', 'Oven', 'Dec', 'Event', and 'Aux'. The 'Oven' tab is selected, showing the following settings:

- Enable:
- SV(°C): 120.00
- PV(°C): 120.00
- Post Run:
  - Post Temp(°C): 200.0
  - Post Time(min): 1.0
- Balance time: 0.1
- Programed Tem:
- Max Oven Temp: 300

Below the settings is a table for temperature programming:

	Slope (°C/min)	Final (°C)	Keep (min)	Total (min)
Init temperature	--	120.00	2.0	2.0
1	5	200.00	2.0	20.0
2	0	0.00	0.0	0.0
3	0	0.00	0.0	0.0
4	0	0.00	0.0	0.0
5	0	0.00	0.0	0.0
6	0	0.00	0.0	0.0
7	0	0.00	0.0	0.0
8	0	0.00	0.0	0.0
9	0	0.00	0.0	0.0
10	0	0.00	0.0	0.0
11	0	0.00	0.0	0.0

At the bottom, the status is 'READY'. The method is '123.da'. Change A time is 25.0min, Change B time is 25.0min, and Change C is Running. There are 'Stop' and 'Finish' buttons.

The heat control is the same as that of the injection port.

Post-Run Temp: Controls temperature after analysis completion.

Post-Run Time: Duration for temperature control after analysis completion.

Balance Time: Stabilization period after reaching the set temperature before the instrument enters ready status.

Max Oven Temp: Protects the chromatographic column. After selecting a column, this value automatically updates to the minimum of all columns' maximum operating temperatures. Manual adjustment is also possible. Exceeding this temperature during operation will trigger protective action and automatic cooling.

### Temperature Programming

Temperature programming refers to the process where the column oven temperature increases according to preset values during sample analysis. Example: Maintain 60 °C for 5 minutes, then ramp at 5 °C/min to 200 °C and hold for 10 minutes. Settings follow the diagram above. Column oven temperature is configured in the temperature interface (not editable here). Subsequent stages follow the same logic.

**Note:** The final temperature of temperature programming must be higher than the column oven's set temperature. Each subsequent stage temperature must exceed the previous stage's

temperature.

**Note:** If the temperature ramp rate of any stage is set to 0, the temperature programming for that stage and all subsequent stages will be invalidated. If the first stage's ramp rate is 0, the entire temperature programming sequence becomes invalid.

#### **Temperature Programming Operation:**

With the instrument powered on, press the "HEAT" button to enter temperature control mode. After the instrument reaches "Ready" status, press the "ANALY" button to initiate temperature programming.

Upon completing a full temperature programming cycle, the post-run program executes. After the post-run time elapses, the instrument automatically opens the column oven rear door to rapidly cool down to the initial temperature, shortening cooling time. When the column oven temperature reaches the initial temperature ( $\pm 1^\circ\text{C}$ ), "Ready" is displayed, awaiting the next temperature programming cycle. This process repeats.

During temperature programming execution, pressing the "Stop" button under the temperature control system will interrupt the temperature programming sequence, returning the instrument to isothermal mode.

**Note:** The termination temperature of the program rise is set higher than the set temperature of the column furnace, and the temperature of the next stage is higher than that of the previous stage.

**Note:** When the heating rate of a certain stage is 0, the programmed heating of that stage and subsequent stages will be invalid; A rate of 0 for the first stage will render the entire programmed temperature content invalid.

#### **Programmed warming operation:**

While the instrument is powered on, press the "HEAT" key to bring the instrument into the temperature control state. When the instrument is in the "Ready" state, press the "ANALY" key again to start the programmed temperature control of the instrument.

When the instrument has completed a full programmed temperature cycle, the post-run program is executed. After the post-run time is completed, the instrument will automatically open the rear door of the column oven to allow the temperature inside the column oven to drop rapidly to the initial temperature, shortening the instrument's cooling time. When the column oven temperature drops to the initial temperature ( $\pm 1^\circ\text{C}$ ), display "Ready" and wait for the next programmed temperature to begin. Repeat this process.

While the instrument is performing the programmed temperature rise, under the

temperature control system, pressing the "Stop" key will interrupt the programmed temperature rise state and the instrument will return to the constant temperature state.

### 3.3.4 Detector parameters

Click the navigation key "Dec" above to bring the instrument into the detector parameters interface, where you can view the detector parameters for each channel as shown in the following figure:

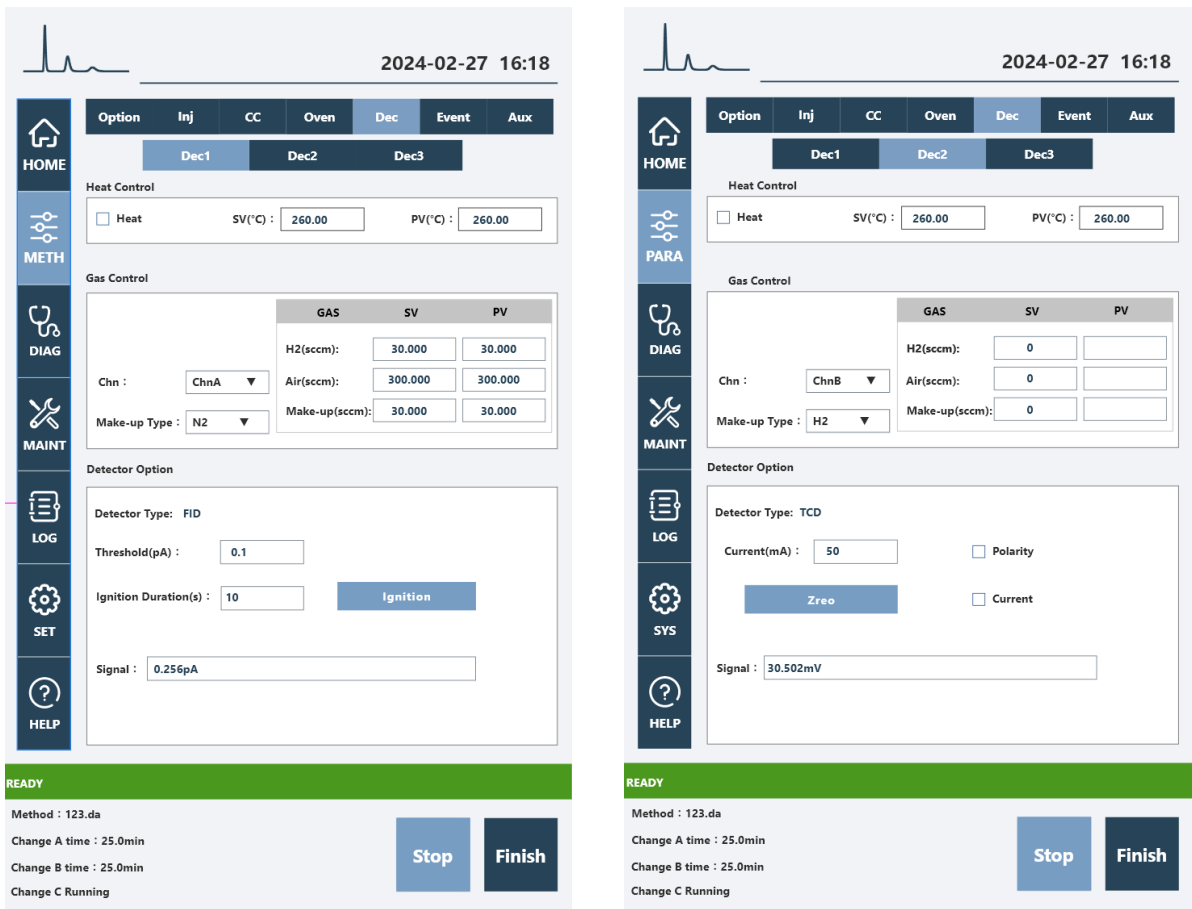

The heating control is the same as the injection port.

Gas Control

Chn: Configure the injection port into the corresponding channel.

Make-up Type: The type of tail blowout gas should be selected correctly.

Set the appropriate hydrogen, air, and tail blow flow rate (different detector types require corresponding parameters)

Detector Option:

FID: Ignition duration, ignition threshold, detector ignition can be set, and signal values corresponding to the detector can be viewed.

TCD: Bridge current, polarity can be set, and signal values of corresponding detectors can be viewed.

ECD: You can set the base current and you can view the signal values of the corresponding detectors.

FPD: You can set the ignition duration, ignition threshold, high voltage value, perform ignition operations on the detector, and you can view the signal value of the corresponding detector.

NPD: You can view the signal value of the corresponding detector.

### 3.3.5 Events

Click the navigation key "Event" above to bring the instrument into the event parameters interface, as shown below:

2024-02-27 16:18

Option	Inj	CC	Oven	Dec	Event	Aux		
	DO1	DO2	DO3	DO4	DO5	DO6	DO7	DO8
ON1	0.01	0.1	0.01	0.1	0.01	0.1	0.01	0.1
OFF1	0.01	0.1	0.01	0.1	0.01	0.1	0.01	0.1
ON2	0.01	0.1	0.01	0.1	0.01	0.1	0.01	0.1
OFF2	0.01	0.1	0.01	0.1	0.01	0.1	0.01	0.1
ON3	0.01	0.1	0.01	0.1	0.01	0.1	0.01	0.1
OFF3	0.01	0.1	0.01	0.1	0.01	0.1	0.01	0.1
ON4	0.01	0.1	0.01	0.1	0.01	0.1	0.01	0.1
OFF4	0.01	0.1	0.01	0.1	0.01	0.1	0.01	0.1

	DO1	DO2	DO3	DO4	DO5	DO6	DO7	DO8
valve	V1	V2	V3	V4	V5	V6	V7	V8
OP	<input checked="" type="checkbox"/>	<input type="checkbox"/>	<input type="checkbox"/>	<input type="checkbox"/>	<input type="checkbox"/>	<input type="checkbox"/>	<input type="checkbox"/>	<input type="checkbox"/>

READY

Method : 123.da  
 Change A time : 25.0min  
 Change B time : 25.0min  
 Change C Running

Stop Finish

There are 8 events in this interface. If you need an external event, set it in this interface.

The buttons below represent the status of each event on/off, and you can manually tap the event on/off.

### 3.3.6 Auxiliary

Click the navigation key "Aux " above:

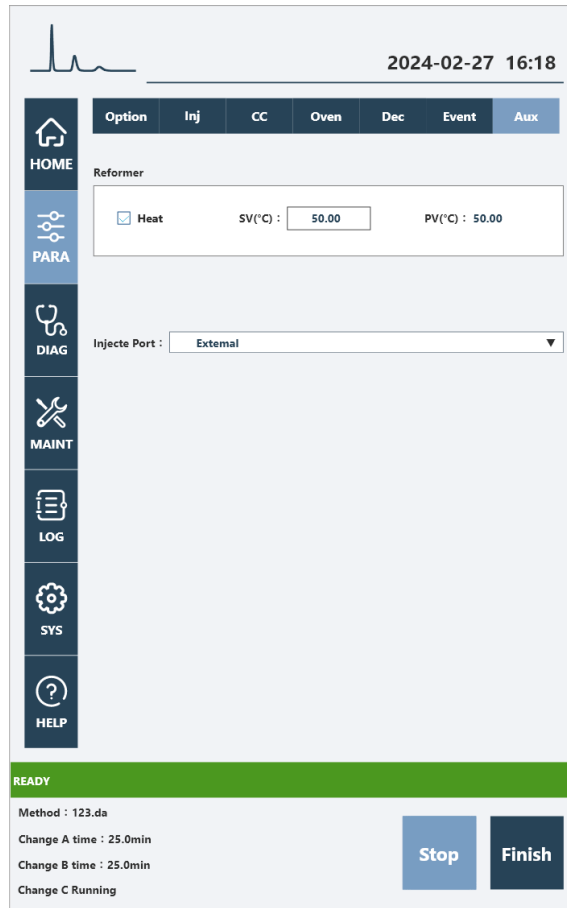

The auxiliary heating system, including the conversion furnace and the sample inlet valve, can be configured. In addition, the sample inlet source can be configured, which is divided into internal trigger and external trigger. Configure the auxiliary heating system, including the conversion furnace and injection valve.

### 3.3.7 Options

Click the navigation key "Option" above:



This interface is for method file management and is independent of the host instrument Options, the upper computer workstation can synchronize the methods stored in the instrument with the "Upload" and "Download" buttons.

## 3.4 Diagnostics

Click on "DIAG" in the left navigation bar to enter the instrument diagnostics interface, which is divided into zero point calibration and internal diagnostics.

### 3.4.1 Zero Calibration

Zero calibration is used to calibrate the flow path sensors of the EPC as shown below:

2024-02-27 16:18

Zero Cal Factory Test

Inject 1

Carr-gas SV(sccm) :	0psi
Split PV(sccm) :	0psi
Purge PV(sccm) :	0.000sccm

Dec1

H2 PV(sccm) :	0psi
Air PV(sccm) :	0psi
Make-up PV(sccm) :	0.000sccm

Inject 1

Carr-gas SV(sccm) :	0psi
Split PV(sccm) :	0psi
Purge PV(sccm) :	0.000sccm

Dec1

H2 PV(sccm) :	0psi
Air PV(sccm) :	0psi
Make-up PV(sccm) :	0.000sccm

Inject 1

Carr-gas SV(sccm) :	0psi
Split PV(sccm) :	0psi
Purge PV(sccm) :	0.000sccm

Dec1

H2 PV(sccm) :	0psi
Air PV(sccm) :	0psi
Make-up PV(sccm) :	0.000sccm

Zero Cal

Pre-cal Off gas inlets, rest 10m!

READY

Method : 123.da  
Change A time : 25.0min  
Change B time : 25.0min  
Change C Running

Stop Finish

#### Zero Calibration Procedure:

1. Shut off the gas supply.
2. Turn off the switches of inlet and outlet tubing connections of the EPC flow path requiring calibration.
3. Allow the system to stabilize for 10 seconds.
4. Click “Zero Cal” on the screen and wait until the measured value stabilizes at 0.

#### 3.4.2 Factory Test

Click the navigation key " Factory Test " above:

The screenshot displays the instrument's control interface. At the top right, the date and time are 2024-02-27 16:18. Below this, there are two tabs: "Zero Cal" and "Factory Test". The left sidebar contains navigation icons for HOME, PARA, DIAG, MAINT, LOG, SYS, and HELP. The main area is divided into two test result sections:

PT100 Test	
NO.	Status
pt100-1 :	Normal
pt100-2 :	Normal
pt100-3 :	Normal
pt100-4 :	Normal
pt100-5 :	Normal
pt100-6 :	Open circuit
pt100-7 :	Open circuit
pt100-8 :	Open circuit

Detector Test	
NO.	Status
Dec1 :	setup
Dec2 :	setup
Dec3 :	none
Dec4 :	none

At the bottom, a green bar indicates the instrument is "READY". Below this, the method is "123.da" and the change times are: Change A time : 25.0min, Change B time : 25.0min, and Change C Running. There are "Stop" and "Finish" buttons on the right.

This interface can detect whether major component connections are normal.

### 3.5 Maintenance

Click on "MAINT" in the left navigation bar to enter the instrument maintenance interface, which is used to view the usage of each injection port and detector consumable.

2024-02-27 16:18

Inj1 Inj2 Inj3 Dec1 Dec2 Dec3

Components	N.U.	S.T.	Reset	Chg Date
Sample spacter	1	999	Reset	2024-06-22
Sample spacter cold	1	999	Reset	2024-06-22
Split cold trap	1	999	Reset	2024-06-22
Liner tube	1	999	Reset	2024-06-22

READY

Method : 123.da  
Change A time : 25.0min  
Change B time : 25.0min  
Change C Running

Stop Finish

2024-02-27 16:18

Inj1 Inj2 Inj3 Dec1 Dec2 Dec3

Components	N.U.	S.T.	Reset	Chg Date
Spray nozzle	1	100	Reset	2024-02-22
Ignition wire	1	100	Reset	2024-02-22

READY

Method : 123.da  
Change A time : 25.0min  
Change B time : 25.0min  
Change C Running

Stop Finish

The injection port components include the injection septum, septum purge trap, split vent trap, and liner; the detector components include the nozzle and ignition filament.

Enter the recommended usage count. When actual usage exceeds this value, the system will prompt for replacement. After replacement, click "Reset" to reset the counter.

### 3.6 Log

Click on "LOG" in the left navigation bar to enter the Log view interface, which is used to view system operation, human operation, and various alarm records.

2024-02-27 16:18

From: 2025 - 05 - 22 - 00 : 00  
To: 2025 - 05 - 23 - 00 : 00

Type: All Contents: All Search Delete

Time	Type	Contents
2025-05-22 13 : 10 : 10	User operation	Touch screen-turn off temperature control
2025-05-22 13 : 08 : 22	User operation	Touch screen-start temperature control

Total 52 Page 10

READY

Method : 123.da  
Change A time : 25.0min  
Change B time : 25.0min  
Change C Running

Stop Finish

## 3.7 System Setting

Click on "SYS" in the left navigation bar to enter the instrument Settings interface.

### 3.7.1 Configuration

The injection port EPC is divided into capillary EPC, dual-channel flow EPC, and the detector can be FID, TCD, ECD, NPD, FPD, etc. This configuration is the manufacturer's configuration. Do not change it at will.

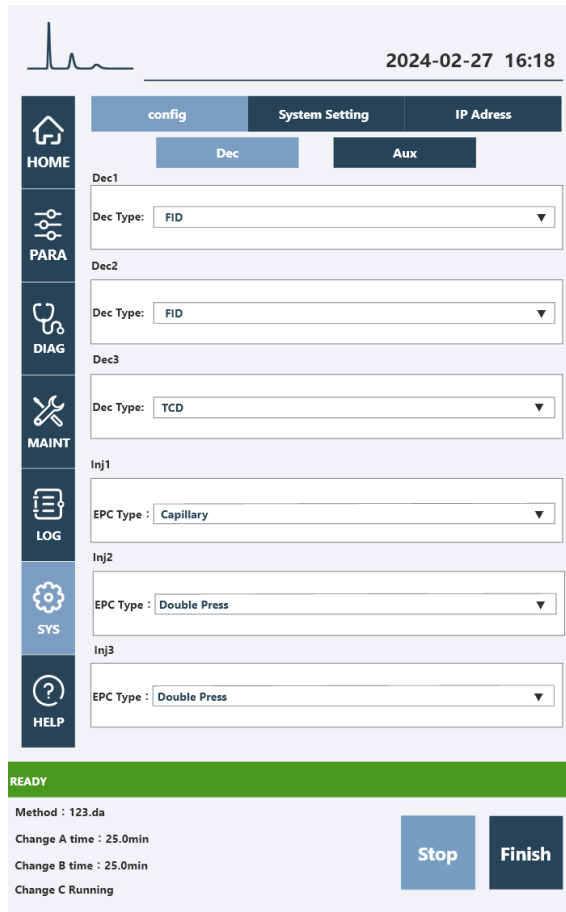

### 3.7.2 System Setting

The system Settings are as shown in the following figure:

The screenshot displays the control interface for the Elite GC2022 Gas Chromatograph. At the top right, the date and time are shown as 2024-02-27 16:18. The interface is divided into three main sections: 'config', 'System Setting', and 'IP Address'. The 'System Setting' section is currently active and contains the following elements:

- A date and time selection field showing 2024 - 02 - 27 - 16 : 18 : 58.
- A 'Recycle Time(min)' input field set to 30, with a 'Sys Time Setting' button to its right.
- A 'Count' input field set to 9999.
- Language selection options:  中文 and  English.
- An 'Update' button for firmware updates.
- Version information: version : V4.4 and Heat version : V4.1.

On the left side, there is a vertical navigation menu with icons for HOME, PARA, DIAG, MAINT, LOG, SYS, and HELP. At the bottom of the interface, a green bar indicates the status 'READY'. Below this bar, the current method is listed as 'Method : 123.da', and there are three buttons: 'Stop' and 'Finish'.

System Time: Enter values and click the " System Setting" button.

Cycle Settings: Enter cycle duration and cycle count. For infinite cycling, set the cycle count to 9999.

Firmware Upgrade: Contact the manufacturer for the upgrade file. Save it to a USB drive, insert into the rear USB port, then click "Update" and wait for completion.

### 3.7.3 IP Address

#### 3.7.3 IP Address

The instrument supports Ethernet or Wi-Fi connectivity. After setting IP addresses respectively, click "IP Address".

Alternatively, the instrument can activate its hotspot. Connect a computer to this hotspot to access the workstation.



### 3.8 Help

Click on "HELP" in the left navigation bar to enter the Help interface, as shown below.

2024-02-27 16:18

HOME

PARAM

DIAG

MAINT

LOG

SYS

HELP

### Precautions for Chromatograph Maintenance

**Installation of Packed Columns**  
 The installation steps for Ø4mm columns are the same as those for Ø3mm columns.

1. Slide the M10×1 Ø3mm column nuts onto both ends of the column.
2. Install the Ø3mm graphite ferrules and liners with corresponding inner diameters.
3. At the detector end, push the column upward until it reaches the bottom and tighten the nut. At the injector end, adjust the height as needed before securing it.
4. Check for leaks using a neutral soap solution. After confirming no leakage, wipe dry.

**Note:** Leave approximately 50mm of empty tubing at the injector end to avoid injection difficulties, and at least 40mm at the detector end to prevent the nozzle from contacting the packing material. Mark the packed column before installation to avoid confusing the injector and detector ends.

**Installation of Capillary Columns**  
 Before installing a fused silica capillary column, ensure the column ends are cleanly cut without burrs. Use a dedicated scoring tool to score and snap the column. Wear protective goggles and handle glass debris carefully. Slide the column nut and ferrule onto the column before cutting. Capillary columns are typically coiled on a metal frame and hung on the column oven bracket. Extend both ends smoothly to the injector and detector interfaces, avoiding contact with the oven walls.  
 At the injector end, extend the column 4-6mm beyond the graphite ferrule. At the detector end, push the column to the top, then retract it by 1-2mm before fixing.  
 Avoid contaminating the column with graphite ferrules and handle rigid columns carefully to prevent injury.

**Maintenance of the Injector**  
 The injector is prone to contamination in the chromatographic system, especially the liner, which accumulates residues. Regular cleaning is required.

1. **Injector Cleaning:** Wipe the injector interior with solvent-moistened cotton swabs. After cleaning, purge with high gas flow to remove residual fibers and solvent.
2. **Liner Cleaning:** Remove the liner and soak it in acetone for 1-2 hours, followed by 30 minutes of ultrasonic cleaning. For stubborn contaminants, use a φ1.6mm stainless steel wire wrapped with acetone-dipped cotton to scrub, then repeat ultrasonic cleaning. Replace the liner if contamination persists.
3. **Injection Septa:** Inspect regularly and replace based on usage counts from the maintenance interface. Ensure proper alignment when installing new septa and tighten the nut securely.

**Note:** After maintenance, perform a strict leak test to confirm no gas leakage before resuming operation. This ensures analytical accuracy and system stability.

**READY**

Method : 123.da

Change A time : 25.0min

Change B time : 25.0min

Change C Running

Stop

Finish

## 4 Instrument maintenance and upkeep

### 4.1 Maintenance of the injection port

The injection port is prone to contamination, especially the inner liner tube, which is prone to adhering contaminants. Therefore, it needs to be cleaned according to usage:

(1) Cleaning of the inlet: It can be cleaned directly with a solvent cotton ball and then blown with a large air flow (mainly to blow off the cotton ball fibers and dry the solvent);

(2) Cleaning of the inner liner tube: After removing the inner liner tube, soak it in acetone for 1-2 hours, then ultrasonicate for more than 30 minutes. If there are stubborn contaminants, use a  $\phi 1.6$  stainless steel wire with a cotton swab dipped in acetone to remove them, then ultrasonicate again. If the inner liner tube is too contaminated to be cleaned, it needs to be replaced.

(3) The injection pad needs to be replaced according to the number of times the maintenance interface is used. After installing the new injection pad, tighten the nut.

The instrument can only be used after a strict leak test after maintenance!

### 4.2 Cleaning of the hydrogen flame ionization detector

1、 Remove the FID amplifier, pull out the signal tube, remove the outer cover fixing nut, then remove the collection tube and insulating gasket, clean the outer cover, collection tube and insulating gasket with acetone or alcohol and then dry;

2、 If contamination is severe, the parts to be cleaned can be placed in the ultrasonic cleaning solution, after ultrasonic treatment, rinsed with clean water, then washed with alcohol and dried;

3、 If the chromatographic stationary liquid is contaminated with the detector, a solvent that can dissolve the stationary liquid should be selected for dissolution.

4、 If the nozzle is contaminated, remove the amplifier signal tube and the outer cover fixing nut, then remove the ion head fixing seat, and then use the sleeve to remove the nozzle. The cleaning method is the same as above.

### 4.3 Installation of the chromatographic column

#### 4.3.1 Packing column installation

The installation of packed columns at both the injection port and the detector is similar. The injection port end of the packed column should be pushed to the top; At the detector end, it

should also be pushed to the top.

Due to the rigidity of the glass, the glass-packed column must be installed at both ends of the injection port and the detector. The installation procedure for each end is the same. For column installation at the detector end, see the corresponding section according to the detector being used.

Connection of Elite GC2022 gas chromatograph  $\Phi 3$ ,  $\Phi 4$ mm packed columns to the injection port.

Installation steps are as follows:

- 1) Insert the M10 $\times$ 1  $\Phi 3$ mm column nuts into both ends of the chromatographic column first;
- 2) Install  $\Phi 3$ mm graphite rings at both ends of the chromatographic column, and then install the corresponding inner diameter liner. Push up to the bottom of the detector (to the bottom) and tighten the nut;
- 3) At the injection port end, adjust the height of the chromatographic column according to specific requirements and tighten the nut;
- 4) Check for leaks with neutral soap solution. There should be no gas leakage.
- 5) Dry the soap solution;
- 6)  $\Phi 4$ mm column installation steps are the same as above;

Note: The injection end of the packed column should have an empty tube about 50mm in length to avoid difficulties during injection. The injection end of the chromatographic column should not be confused with the detector end and should be marked when filling the packed column. A sufficient section of empty column (at least 40mm) should also be left at the detector end to prevent the bottom of the nozzle from touching the glass fiber or column packing filled at the column end.

---

### **4.3.2 Installation of the capillary column**

The fused silica capillary column is very regular and does not require tiling. But it is important that the column ends be freshly cut, hairless, and neatly edged, and that particulate matter from the column, the stationary phase, and the sealing gasket is removed.

For this purpose, the end of the column should be freshly cut, and scratches should be made on the area to be cut with a suitable specialized cutting tool. Usually the column nuts and washers are installed before cutting.



Note: Wear protective glasses to prevent possible eye injury from flying particulate matter that may be produced when handling cutting glass or fused silica capillary columns. Care should also be taken to prevent skin cuts when handling capillary columns. Since the column is quite rigid, it is important to be aware of these in advance when handling the capillary column.

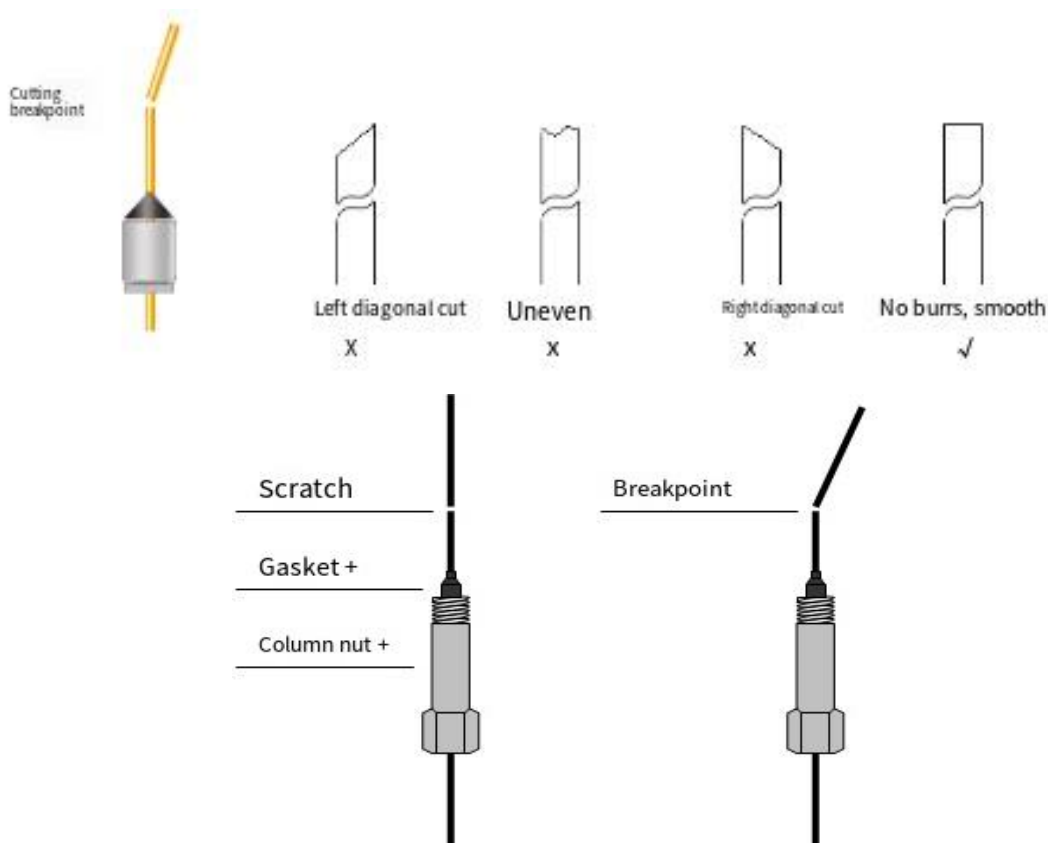

The capillary column is wound around a metal frame, which is suspended from the capillary column bracket in the column box. The two ends of the column extend from the bottom of the frame and bend smoothly towards the interface of the injection port and detector, and do not let any part of the column touch the inner wall of the column box. Graphite gaskets may contaminate the column as they pass through it. Cut the column ends as described in "Preparing a Fused Silica Capillary Column".

The following figure shows the reserved lengths for the injector end and FID end when installing the elastic quartz capillary column. The injector end should extend 4-6mm beyond the graphite pad, and the detector end should push the chromatographic column up to the top and

then pull down 1-2mm.

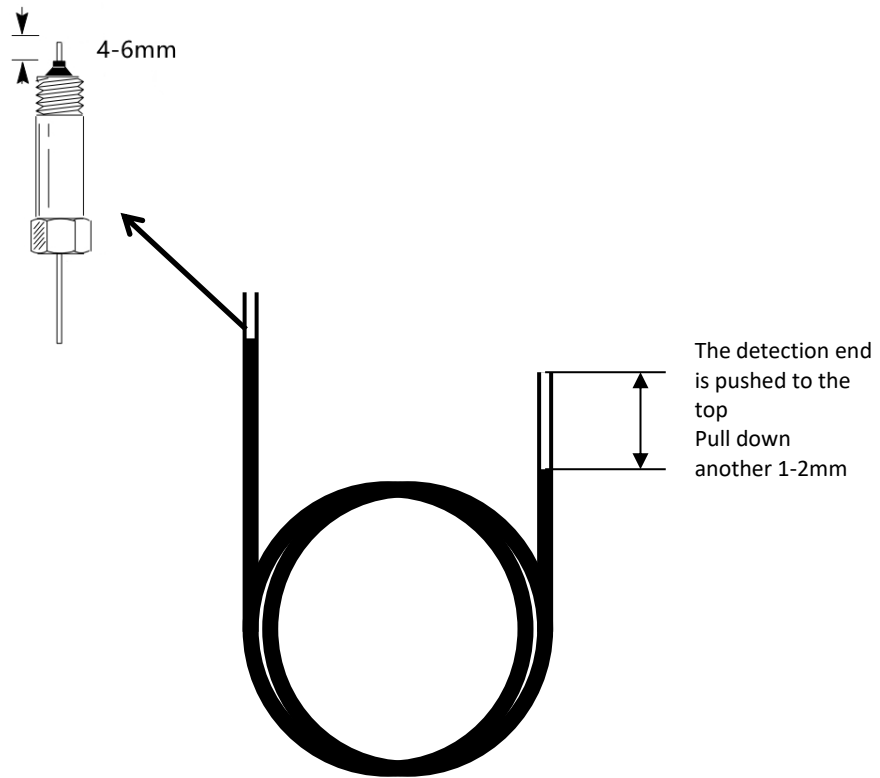

# 5 Instrument faults and troubleshooting

## 5.1 Startup Issues

### 5.1.1 No response at startup

Fault diagnosis	Check methods and repairs
Mains power issues	Check the mains voltage
The fuse has blown	Check the fuse and replace it
The display screen is not working.	Check if the motherboard lights up

### 5.1.2 Not online

Fault diagnosis	Check methods and repairs
Network cable problem	Check the network cable and PING this GC on your PC
The IP address is set incorrectly	Check the IP address and set it correctly
The computer operating system firewall is blocking	Remove the firewall blocking
Computer antivirus software blocks	Remove the blocking of antivirus software
The network indicator light of the computer or chromatograph is not on	Check the network cable, switch, chromatograph or computer
Connected but disconnected from time to time	Check whether the network and IP addresses are in conflict

## 5.2 Chromatographic peak issues

### 5.2.1 No baseline

Fault Diagnosis	Check methods and repairs
Amplifier malfunction	Replace the amplifier
Set the baseline and background colors to the same color	Modify the color
The chromatograph is not connected to the computer	Check the network and network parameters

### 5.2.2 No chromatographic peaks

Fault diagnosis	Check methods and repairs
The inlet temperature is too low	Increase the inlet temperature
The syringe is clogged.	Replace the syringe

There is no carrier gas passing through	Check if the carrier gas flow path is blocked or if the gas in the cylinder has run out
Silicone rubber leaks	Replace silicone rubber
No flame	Light up
FID amplifier broken	Replace the amplifier
The TCD is not bridged	Set the appropriate bridge current

### 5.2.3 Normal retention time but decreased sensitivity

Fault diagnosis	Check methods and repairs
Leaking syringe	Replace the syringe
Carrier gas leak	Test for leaks and deal with them accordingly
Improper selection of hydrogen and air flow (FID)	Adjust the flow rate accordingly

### 5.2.4 Tail peak

Fault Diagnosis	Check methods and repairs
Contamination of the injection tube	Clean the inlet tube
The oven temperature of the chromatographic column is too low	Increase the temperature of the chromatographic column
The injection temperature is too low	Raise the inlet temperature
Improper selection of the chromatographic column	Choose the appropriate chromatographic column

### 5.2.5 Tongue Extension Peak

Fault diagnosis	Check methods and repairs
The sample size is too large	Reduce the sample size
Samples are aggregated in the system	Raise the column temperature first, then select the appropriate inlet, chromatographic column, detector temperature

### 5.2.6 Poor separation of chromatographic peaks

Fault diagnosis	Check methods and repairs
The chromatographic column is too short	Choose a longer column
Loss of stationary phase	Replace the chromatographic column or age it
Column temperature too high	Lower the column temperature
The selection of the stationary liquid is incorrect	Select the appropriate chromatographic column

The carrier gas flow rate is too high or too low	Adjust the carrier gas flow rate
--	----------------------------------

### 5.2.7 Baseline mutation

Fault diagnosis	Check methods and handling
External electric field interference	Eliminate external electric field interference that affects the normal operation of the instrument
Poor contact of the power plug	Install the power socket firmly
Improper selection of hydrogen and air flow	Readjust the flow rates of hydrogen and air

### 5.2.8 Irregular baseline fluctuations during constant temperature operation

Fault diagnosis	Check methods and repairs
The position where the instrument is installed is not good	Install the instrument in a place where there is no strong vibration. It is best to place the instrument on a concrete platform without vibration.
The instrument is poorly grounded.	Check and ensure proper grounding
The fixative is not appropriate	Choose the appropriate fixative
The carrier gas flow rate is not chosen properly	Adjust the carrier gas flow appropriately
Carrier gas leak	Leak test
Detector contamination	Clean the detector
Improper selection of hydrogen and air (FID)	Adjust the flow of hydrogen and air appropriately

### 5.2.9 Prolonged retention time leads to low sensitivity

Fault diagnosis	Check methods and repairs
The carrier gas flow rate is too slow	Increase the carrier gas flow rate
Change the carrier gas flow rate after injection	Change the injection port silicone rubber
Injection port silicone rubber leaks	Replace the injection port silicone rubber

### 5.2.10 The signal suddenly returns below baseline and extinguishes the fire when the peak comes out

Fault diagnosis	Check methods and repairs
The sample size is too large	Reduce the sample size
The carrier gas flow rate is too high	Choose the appropriate carrier gas flow rate
The hydrogen or air flow rate is too low	Readjust the flow rate of hydrogen and air

Flame nozzle contamination	Clean the flamethrowers
The stationary phase in the chromatographic column has leaked	Re-age the column

### 5.2.11 Baseline too high

Fault Diagnosis	Check methods and repairs
Detector contamination	Clean the detector
Amplifier failure	Check the amplifier

### 5.2.12 There are spike peaks in irregular distances

Fault diagnosis	Check methods and repairs
Amplifier failure	Replace the amplifier
Flame flicker	Adjust the appropriate flow of hydrogen and air
High frequency signal tube failure	Check the high-frequency signal tube
Dust on the detector	Blow it off with an ear swab

### 5.2.13 There is a certain amount of burrs at equal intervals

Fault diagnosis	Check methods and repairs
Water condenses in the hydrogen pipeline	Remove the water from the pipeline and replace or activate the desiccant
There is a blockage in the flow path	Remove impurities from the flow path
Leaking air	Test for leaks and take corresponding measures
Flame flicker	Adjust the appropriate flow of hydrogen and air

### 5.2.14 Round peak

Fault diagnosis	Check methods and repairs
Beyond detector linear range (TCD)	Reduce the sample volume
Improper bridge flow selection (TCD)	Reselect the appropriate bridge flow

### 5.2.15 Baseline noise is high

Fault diagnosis	Check methods and repairs
Contamination of the chromatographic column	Replace the chromatography column
Carrier gas contamination	Replace or regenerate the carrier gas filter

The carrier gas flow rate is too high	Readjust the carrier gas flow rate
Poor grounding	Check and make good grounding
Contamination of the injection port	Clean the inner liner tube of the injection port
Too high or too low air or hydrogen flow rate (FID)	Readjust the flow rate of air or hydrogen
Air or hydrogen contamination	Replace the hydrogen or air filter
Water condenses in the FID	Increase the FID temperature to remove the moisture
High frequency signal tube failure	Check the high-frequency signal tube

### 5.2.16 Extra peaks

Fault diagnosis	Check methods and repairs
Reconstituted peaks of the previous sample	Wait until the previous sample has been completely expelled before injecting
The water condensed in the chromatographic column is eluted again	The operating conditions for installing or regenerating the purifier should be chosen appropriately
Sample decomposition	Lower the inlet temperature
Samples contaminated	Make sure the sample is clean

### 5.2.17 Serrated baseline

Fault Diagnosis	Check methods and repairs
EPC flow oscillation	Replace EPC
The airflow is not flowing properly	Reset the flow rate of the airflow

### 5.2.18 Reverse peak

Fault diagnosis	Check methods and repairs
Excessive hydrogen flow (FID)	Adjust the hydrogen flow rate
Incorrect Polarity (TCD)	Change polarity
The tungsten filament leads of the reference cell and the measurement cell are mistaken (TCD)	Check the lead conditions of the tungsten wires in the reference cell and the measurement cell.

### 5.2.19 Baseline unidirectional baseline drift (FID) without injection

Fault diagnosis	Check methods and repairs
Detector temperature too low	Raise the detector temperature
Column temperature stops heating or gets out of control	Inspect and repair the temperature control system and the platinum resistance of the heating

	wire
Leaking air	Leak test

### 5.2.20 Irregular baseline changes during heating

Fault diagnosis	Check methods and repairs
Excessive column loss	Select the appropriate chromatographic column, use the column temperature which should be much lower than the maximum operating temperature of the stationary phase, and age the column
The appropriate operating conditions were not chosen	Choose the appropriate operating conditions
The chromatographic column is contaminated	Replace the chromatographic column

### 5.2.21 Periodic baseline fluctuations

Fault diagnosis	Check methods and repairs
Detector temperature control is poor	Check whether the contact is good
The carrier gas flow pressure is too low	Replace the carrier gas cylinder
The temperature of the chromatographic column furnace was not properly adjusted	Check if the platinum resistance contact is good
The carrier gas flow is not properly regulated	Re-adjust the carrier gas flow rate
Improper adjustment of air and hydrogen (FID)	Recalibrate the flow of hydrogen and air

### 5.2.22 Baseline changes after programmed temperature rise

Fault diagnosis	Check methods and repairs
Column loss increases as the temperature rises	Select an appropriate chromatographic column or an aged column
The column flow rate is not corrected properly	Correcting column flow rate
The chromatographic column is contaminated	Replace the chromatographic column

### 5.2.23 Uninjected Signal output amplitude too large (TCD)

Fault Diagnosis	Check methods and repairs
The tungsten wire in the cavity touches the pool wall	Contact the manufacturer for repair
The resistance values of the tungsten wire do not match	Contact the manufacturer for repair
The internal connectors and connection wires of the TCD thermal conductive power component are not properly inserted	Reinsert the plugs and sockets associated with it

### 5.3 Thermal Conductivity Detector Precautions

#### **Carrier Gas and Bridge Current Settings:**

Bridge current must never be set before carrier gas flow is established. Without carrier gas for cooling, excessive bridge current may cause overheating and burnout of the tungsten filaments. Therefore, ensure carrier gas is properly flowing before setting bridge current.

#### **Column Conditioning and Carrier Gas Handling:**

During initial column conditioning, route the outlet carrier gas to vent inside the column oven rather than connecting it to the thermal conductivity cell (TCD). Additionally, hydrogen is strictly prohibited during conditioning; nitrogen is typically recommended. Absolutely no bridge current should be set during conditioning to prevent detector damage.

#### **Thermal Conductivity Cell Protection:**

The TCD is a highly sensitive component with intricate and fragile internal structures. Do not attempt to disassemble tungsten filaments or other elements within the cell, as this may cause irreparable damage or loss.

# Appendix A Electrical Requirements Specification

A qualified electrical technician must be capable of providing suitable power to the system. This requirement applies to both modifying existing electrical installations and installing new equipment.

Estimate the total power demand for the area.

Install conveniently accessible branch circuits.

Develop plans for electrical safety compliance.

Ensure all wiring adheres to local codes.

Determining Power Requirements

Calculate the power consumption required for your area.

Note: Total power must account for originally specified equipment plus planned future expansions.

## **Voltage Limits**

At any instrument installation site, the phase-to-neutral voltage must remain within +10% to -10% of nominal voltage during system operation. Voltage shall be measured at the system's power input point.

## **Frequency Limits**

Permissible line frequency limits depend on the equipment with the narrowest tolerance range within the system (measured at the instrument's power cord input). The Elite GC2022 network gas chromatograph features wide limits, operating between 50Hz and 60Hz.

## **Harmonic Distortion**

Total harmonic distortion on instrument feeders shall not exceed 5% (measured at instrument power input during operation).

## **Power Line Anomalies**

In some areas, power lines serving instrument systems may experience excessive voltage sags, surges, transients, outages, or other anomalies compromising operational reliability. Power quality must therefore be verified. Any deviations from system requirements identified during inspection must be corrected.

## **Power Line Noise**

The Elite GC2022 network analyzer is designed to withstand reasonable input line noise. However,

noise originating from other utility-powered equipment cannot be controlled by the analyzer.

Primary sources include nearby electrical devices such as motors, solenoid valves, SCR drives, and X-ray machines.

Additionally, "neutral-to-ground noise" from poor neutral connections and "ground-to-ground noise" from inadequate floor grounding may occur. Maximum permissible line noise is 3V RMS across 30Hz to 50kHz.

An oscilloscope should measure minor "ground-to-neutral" voltage, as analog meter readings may distort with waveform deviations. Generally, voltage readings below measurement results indicate potential issues.

### **Noise Mitigation**

To eliminate noise from existing or future electrical equipment, we strongly recommend installing a dedicated feeder between the main distribution panel and the instrument subpanel. Verify neutral connections and grounding integrity (refer to "Grounding" section below).

If adverse transients persist after installing a dedicated feeder, power conditioning equipment must be added to reduce input line noise.

### **Power Line Disturbances**

Input power noise interfering with power output or system signal lines may cause instrument malfunction. These disturbances are categorized as follows:

Surges and sags refer to abrupt positive/negative voltage changes lasting between 5ms and 50ms. Typically, surges/sags should not exceed  $\pm 15\%$  of nominal line voltage and must recover to steady-state within 17ms (60Hz) or 20ms (50Hz).

Power line transients are abrupt voltage changes lasting 1ms to 5ms. Transients exceeding 20% of nominal voltage (depending on energy) may disrupt instrument operation.

A power line disturbance monitor proves valuable for assessing input power quality and characterizing disturbances. Since line disturbances may occur hourly, daily, or weekly, monitoring should continue for at least one week. Recorded values should not be considered absolute, as seasonal variations affect disturbance levels.

Test methodology: Apply spikes with 0.5 $\mu$ s rise time, 10 $\mu$ s pulse duration, and amplitude equaling twice the supply voltage.

### **Power Conditioning Equipment**

If transients persist after installing dedicated feeders and grounding, implement equipment to reduce input line disturbances. Four primary solutions exist:

Isolation transformers

Voltage regulators

Motor-generator sets

Uninterruptible power supply (UPS) systems

Line conditioning equipment must meet current and future power requirements. Our recommended minimum rating is 5kVA to accommodate both present needs and future expansions.

## Appendix B Grounding

To ensure the safe and reliable operation of instruments, proper grounding is crucial. Generally, most countries and regions require electrical equipment to be equipped with grounding conductors to ensure personal safety.

### **Safety Grounding**

Various standards typically mandate the installation of safety conductors for electrical equipment. Such standards often stipulate that each live wire return line (neutral) must be accompanied by a safety conductor, whose size must match that of the live wire.

Safety standards generally require the safety conductor to be connected to conductive surfaces of electrical equipment that operators may contact or surfaces that could become energized due to electrical faults. Under normal operating conditions, this conductor should not carry returning AC current. If an instrument's chassis is ungrounded or if a live wire accidentally contacts the chassis, the voltage on the chassis may reach hazardous levels.

Connecting the safety ground wire to the instrument's chassis prevents electric shock by creating an extremely low-impedance path, triggering circuit breakers or blowing fuses. Each instrument product includes safety grounding provisions. Completing this circuit requires connecting the instrument to a grounded outlet or attaching the instrument's grounding lug to a ground wire meeting user specifications.

As described below, the instrument's safety ground is typically bonded to the building's conduit via an insulated grounding device, which in turn grounds the subcircuit distribution. Compliance with local and national safety codes is mandatory in all cases.

The safety ground wire must be properly terminated at the main distribution ground bus. It is essential to understand that the impedance from any load back to the main ground bus must be less than 11 ohms.

### **Noise-Free Grounding**

For optimal performance of the Elite GC2022 network instrument, we strongly recommend

implementing a noise-free ground. This grounding is also termed "isolated ground" as it is separated from other electrical grounds in the building. Using an "isolated ground" enhances system reliability when connecting the Elite GC2022 to other instruments.

Conventional grounding is often inadequate because it invariably introduces noise from poor grounding practices. Noise may also originate from RF transmitters, and ground wires may carry steady-state currents.

Typical noise-prone grounding sources include:

Conduits

Roof and building beams

Sprinkler pipes (grounding to these pipes is prohibited by most fire codes)

Raised-floor support structures

Gas pipes

Grounding to these pipes subjects the system to building noise from poor grounding and RF interference via antenna effects.

Acceptable grounding points (consult local electrical authorities for approved methods):

Bonding with appropriately sized wire to the building's main pipe or conduit entry point.

Driving grounding rods into moist soil and connecting to the entry point.

Connection to other reliable earth entry points.

Isolated ground wires must be securely terminated. Avoid using clamps on pipes or grounding posts, or any method that may loosen connections. Terminals should be soldered (brazed or tinned) to minimize insulation resistance degradation at joints. Improper installation may introduce resistance at joints, which—combined with wire resistance—can create undesirable potentials in the isolated ground system. Prevent accidental contact with other grounds during installation to avoid compromising isolation. The isolated wire must connect to an isolated bus in the distribution panel, then separately route via terminals to individual units of the instrument system. The isolated bus may be a grounding plate within the distribution panel.

Wire sizing should minimize ground resistance from the farthest point to the main panel's ground point. Consult local authorities for wire specifications.

When installing power conditioning equipment in multi-story buildings, bond the equipment enclosure to the building's structural steel to reduce ground noise. Connect one end to the equipment chassis and weld the other end to the nearest vertical steel beam. This method is superior to grounding rods in basements.

Measuring Neutral-to-Ground Connection Quality

Specialized devices for assessing ground system quality are commercially available, including:

Ground testers that induce current in ground wires and indicate quality (via indicator lights or ohm-scale readings).

Ground resistance testers for measuring ground system resistance.

If ground impedance is excessive, inspect the following:

Verify the neutral-to-ground (N-G) connection integrity at the building's main distribution panel if no power conditioner or designated ground exists.

Recheck N-G connections at power conditioning equipment if installed. Relocate suboptimal N-G terminations to prevent unwanted currents in grounding conductors.

Inspect ground conductor connections. Replace undersized or uninsulated ground wires with insulated conductors matching circuit wire dimensions.

#### Electrical Load Balancing

Balancing loads in three-phase and split-phase systems is critical because:

- It mitigates adverse effects of external voltage drops and fluctuations on equipment powered by individual transformers.
- It enhances the performance of isolation transformers.
- It extends transformer service life.

Unbalanced loads create voltage differences between neutral and ground. Measure this voltage to assess balance. For load balancing:

Use a clamp-on ammeter to measure current per phase.

Disconnect power lines from the instrument system's distribution panel and redistribute loads.

Remeasure and repeat until neutral current is minimized.

Neutral-to-ground voltage measurement also validates load balance:

Power on the instrument and measure N-G voltage at its input terminals using an oscilloscope (with minimal probe lead length).

Disconnect power, redistribute loads, and remeasure.

Repeat until N-G voltage is minimized.

N-G voltage may further decrease when balancing other feeders or increasing feeder sizes. If N-G voltage remains excessive at the system panel, install a dedicated feeder from the main distribution panel.