

ECLASSICAL
3200L
UHPLC

USER
MANUAL

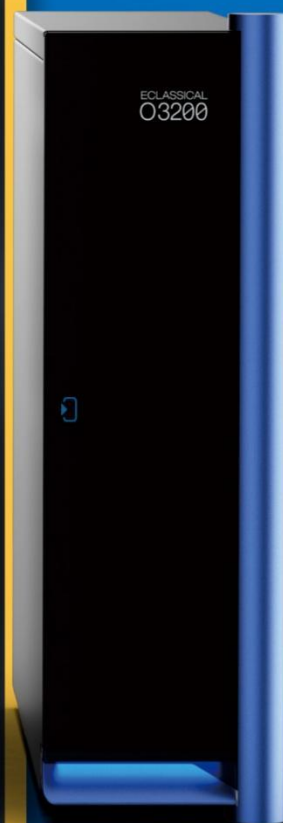

Operation Manual
for D3270L Evaporative
Light Scattering Detector

V1.0.4

Statement

This manual is only for users to understand, use and maintain EClassical D3270L ELSD. Elite Analytical Instruments Co., Ltd does not assume the responsibility caused by business or special purpose use of the manual.

The information in this document is subject to change without notice and should not be construed as a commitment by Elite Analytical Instruments Co., Ltd.

This manual is believed to be complete and accurate at the time of publication. Elite Analytical Instruments Co., Ltd assumes no responsibility for any errors that may appear in this document.

In no event shall Elite Analytical Instruments Co., Ltd be liable for incidental or consequential damages in connection with, or arising from, the use of this manual.

The Copyright of the manual is owned by Elite Analytical Instrument Co., Ltd. This book or parts thereof may not be reproduced in any form without the written permission of the Elite Analytical Instrument Co., Ltd.

Please read the specification carefully before use D3270L ELSD.

Preface

Thank you for purchasing our equipment. To ensure correct and safe use of the instrument, please read it carefully before using.

The details of the equipment's composition, installation, method of using, maintenance, parts selection and other points are described in the manual. After reading, please keep it carefully. Please delivery the manual with the instrument.

For safe operation, please read the following **Safety Precautions** before using the instrument.

Safety Precautions

According to the level of danger and harm, safety signs here are divided into the following three categories:



【Warning】

Failure to properly follow the instructions and precautions indicated by this sign may result in serious injury or damage to health and property. The property damage includes the environment around and the instrument.



【Caution】

Failure to properly follow the instructions and precautions indicated by this sign may result in slight injury or damage to health and property. Slight injury means no hospitalization is needed to the wounded. Slight property damage means the instrument can be recovery through simple maintenance.



【Note】

The sign is used wherever information is given to ensure optimal performance of the instrument.

1. Precaution for usage



[Warning] D3270L should only be used as a part of liquid chromatography. Do not use it for any other purpose. Except for special instructions, the instrument does not have explosion-proof function.

2. Ambient Conditions



[Warning] When we use organic solvent it is recommended that interior must be well ventilated and the firework should be prohibited. Also, a sink or equipment for washing eyes should be installed nearby in case of the organic solvent meeting the eyes or skin.



[Note] In order to ensure good efficiency, keep the instrument away from caustic gas, dusty environment or strong magnetic. The worktable should be wide and strong enough. Ambient should be between 10°C to 30°C with a small fluctuation, and humidity should be between 20% to 80%. Avoid it from cold or hot source as well as direct sunshine. The air conditioners and other equipment should not blow directly into the instrument.

3. Precaution for installation



[Warning] The instrument should be installed following the instructions strictly by professionals, make sure that the voltage of the power socket is the same as the power supply voltage indicated on the instrument. Using the wrong power voltage could result in danger and fire.

The accessory power cable should be used to connect the pump to the power socket. Other cable should not be used.

Make sure the line cord is connected to a properly grounded power receptacle to prevent static and electric leakage.



[Caution] The instrument is so heavy that you should move it carefully and watch your hands in the same time.



[Note] The instrument should be connected following the instructions strictly. Wrong connection could cause communication error.

4. Precautions for use



[Warning] Do not use the instrument in places where heat resource, fire seat, magnetic resource, strong vibration exist or may exist. It is prohibited to put flammable nearby.

The bottle for storing the mobile phase should have a pore in cap to prevent the danger caused by negative pressure in the bottle.

A gap between the waste tubing and the cork of the waste bottle is necessary to prevent the waste bottle bursting when it is overfilled. But the gap should be small to prevent evaporate of hazardous solvents. Even though, the waste need to be clean up promptly.

The detector outlet should be connected to a fume hood or similar equipment. To ensure that the generated gas does not leak to the laboratory. According to the requirements of local environmental law, the use of relevant solvent filter can be considered.

If the mobile phase contains organic reagents, use nitrogen to atomize the mobile phase.

Do not use solvents or gases (such as pure oxygen or hydrogen) that will burn when the instrument reaches a certain temperature.

Please keep the input gas dry, otherwise the gas flow control device inside the instrument will be damaged.

The gas pressure should not exceed 10 bar (145 psi) to ensure that the gas flow is stable as the mobile phase flows through the detector. If the gas flow is interrupted for a long time, the organic solvent may damage the photomultiplier tube.

Do not remove the laser or photomultiplier tube when the instrument is powered on, otherwise the photomultiplier tube will be damaged.

When the instrument is powered on, please do not pull out the waste gas bellows at the back of the instrument, or the photomultiplier tube will be damaged.

If the harmful substance splashes on the surface of the instrument or falls into the instrument, it should be removed in time.

The user shall be responsible for the recycling of the detector. Do not throw electrical or electronic products into domestic waste. This product is defined as testing and control instrument products. The internal parts of the detector have no recovery hazard. Clean the detector to ensure that there is no solution or solute residue in the detector drift tube.

If the instrument is not used according to the requirements of our company, the relevant instrument protection may be invalid.



[Caution] When using organic solvents, please wear safety goggles, special lab coats, gloves mask etc. If your body contact with toxic solvent accidentally, wash it immediately, and then go to hospital for specialized treatment.



[Note] When preparing mobile phase, please use HPLC grade solvents or equivalent ones. You'd better filtrate the eluent with a membrane filter (0.45 μ m), and a online filter is also necessary to prevent small particles from scratching plunger rod, seal ring or blocking tubing. What's more, please degas all mobile phase before using, degassing is an effective method to prevent chromatogram noise and wrong indicator.

Before first use, rinse the entire piping system according to the requirements of the manual. Direct use is likely to block tubing.

Before sample test, ensure that the tubing in the system is filled with mobile phase without any bubbles, otherwise it will affect the reliability of test results.

If an eluent is replaced with another eluent which is insoluble, such as positive mobile phase (hexane) and reverse phase (methanol), be sure to operate according to the specified method in the manual, otherwise it will cause serious tubing jam, and even system paralysis.

Halogen ions is harmful for stainless steel, if there is stainless steel tubing and fitting in your system, please avoid the use of a mobile phase containing halogen ions. If you can't avoid it, please minimize the content and clean the system with water as soon as finishing the analysis.

If there is peek tubing in your system, it is important to note that:

Do not use the following solvent: concentrated sulfuric acid, nitric acid, dichloroacetic acid, dichloromethane, trichloromethane, chloroform, dimethyl sulfoxide, acetone, tetrahydrofuran, etc. Such solvents can reduce the strength of the PEEK material, make it's become fragile and broken. But the impact of short-term use of aqueous solution of acetone (lower than 0.5%) in gradient performance is acceptable.

When using PEEK tubing, the pressure of the system should be lower than the tolerance pressure of peek material, otherwise it may burst.

The bending radius of peek tubing should be more than 10mm, make the peek tubing natural relaxation during installation.

The PEEK tubing should be intercepted with professional tubing cutter in order to make the tubing more smooth. Pay attention to that there should be no cutting debris left in the tubing.

5. Repair, maintenance and parts replacement



[Warning] Before repair, maintenance and parts replacement, please turn off the power in case of leakage and electric shock.

There is no need to open the host cover while daily maintenance and repair. If the repair needs to open the host cover please entrust agents or communicate with us.

You should clean the dust on the power cord plug regularly to reduce the electrostatic. Then, dry it before using, otherwise electric shock may occur.

Use dry cloth to wipe the instrument. Do not use thinner or alcohol to avoid erasing characters or color on the panel.

Do not replace components (e.g. fuses, deuterium lamp, etc.) from other company or other type, all accessories are required to be specified to prevent danger.

6. Precaution for static electricity









[Warning] As the instrument may use a lot of flammable, explosive organic reagents which may contaminate laboratory air, when the reagent concentration is too high, any spark or flame could cause fire or explosion accidents. Do not use the pump near any fire resource or hot resource, and keep reducing the electrostatic in mind. To reduce static electricity, please take the following measures:

- 1) Make the instrument grounded. It is very important, please pay attention to it.
- 2) Maintain proper indoor humidity (humidity is greater than 65% can prevent static electricity effectively) and keep the environment clean.
- 3) Metal waste bottles (external conductive) should be grounded (no ground insulation). When using other materials container, you can insert one end of the wire into liquid in the bottle and make the other end earthed.
- 4) Replace a larger I.D. tubing when the flow of mobile phase is higher than usual.
- 5) Wipe the instrument regularly.
- 6) Staffs should wear anti-static clothing. An anti-static pad is needed on the floor.
- 7) People and objects with static electricity is prohibited to touch the instruments.

7. Warning label description

To ensure the safety of staffs, we attach warning labels on the equipment where are dangerous. If the label is missing, please request new ones from our company, and attach to the correct position.

The following table lists all the safety signs used on the instrument and in the instructions and their meanings:

Symbol	Meaning
	Warning (Please refer to the user manual for more information)
	shock hazard
	Toxic gas inhalation hazard
	High temperature warning
	Warning, beware of hot hands.
	Beware of laser radiation.
	Instrument damage warning

Contents

CHAPTER 1 INTRODUCTION	1
1.1 OVERVIEW.....	1
1.2 PRINCIPLE.....	2
1.3 PERFORMANCE SPECIFICATION	4
1.4 PHYSICAL SPECIFICATIONS	5
1.5 APPEARANCE	6
CHAPTER 2 INSTALLATION AND TRANSPORTATION	1
2.1 UNPACKING ACCEPTANCE	1
2.1.1 <i>Unpacking</i>	1
2.1.2 <i>Deliver checklist</i>	2
2.2 STACK ORDER	1
2.3 INSTALLATION REQUIREMENTS.....	2
2.3.1 <i>Site requirements</i>	2
2.3.2 <i>Power Line</i>	5
2.3.3 <i>Gas requirements</i>	6
2.4 COMPONENT CONNECTION	7
2.4.1 <i>Gas connection</i>	7
2.4.2 <i>Exhaust pipe connection</i>	7
2.4.3 <i>Atomization unit connection</i>	8
2.5 COMMUNICATION CONNECTION.....	11
2.5.1 <i>Circuit connection</i>	11
2.5.2 <i>Communication connection</i>	12
2.1 PIPELINE AND FLOW PATH CONNECTION	13
2.6.1 <i>Pipeline connection</i>	14
2.6.2 <i>Flow connection</i>	15
2.2 EXTERNAL TRIGGER	21
2.3 PREPARATION	21
2.4 VERIFICATION.....	22
2.5 TRANSPORTATION	23
3. INSTRUMENT OPERATION	1
3.1 POWER ON AND OFF.....	1
3.2 SOFTWARE INSTALLATION	2
3.2.1 <i>Computer Requirements</i>	2
3.2.2 <i>Computer Network IP Settings</i>	3
3.2.3 <i>Kromstation instal</i>	6
3.3 WORKSTATION STRUCTURE	7
3.4 SYSTEM CONFIGURATION.....	8
3.5 MAIN INTERFACE INTRODUCTION	10
3.6 INSTRUMENT PREHEATING TIME	12
3.7 OPERATION METHOD	12
3.8 BASELINE AUTO ZERO.....	13
4. HANDHELD CONTROLLER OPERATION	1
4.1 INSTALLATION.....	1
4.2 KEY DESCRIPTION OF HANDHELD CONTROLLER.....	1
4.2.1 <i>Set evaporation temperature</i>	1
4.2.2 <i>setting carrier gas flow</i>	2
4.2.3 <i>set atomizing nozzle for heating</i>	3
4.2.4 <i>setting sensitivity</i>	5
4.2.5 <i>Setting bias voltage</i>	5

4.2.6 Setting output range	6
4.2.7 Setting the sampling frequency.....	7
4.2.8 Set filter	7
4.2.9 Set the startup to zero.....	8
4.2.10 Set the output function.....	9
4.2.11 Setting temperature alarm.....	9
4.2.12 Set the flow alarm.	12
4.2.13 Setting pressure alarm	14
4.2.14 Set the communication mode.....	15
4.2.15 Storage method.....	18
4.2.16 Loading method	20
4.2.17 Restore the default settings.....	20
4.2.18 Version information	21
5.TROUBLESHOOTING AND DIAGNOSIS.....	23
5.1 ERROR LIST OF PC	23
5.2 OTHER TROUBLESHOOTING AND TREATMENT	25
6. MAINTENANCE AND REPAIR.....	1
6.1 DAILY MAINTENANCE.....	1
6.2 DAILY SHUTDOWN PROCESS.....	2
6.3 INSTRUMENT CLEANING AND DISINFECTION	3
6.3.1 External cleaning of instrument.....	3
6.3.2 Internal disinfection of instrument.....	3
6.4 ATOMIZER NOZZLE CLEANING	4
7. PARTS AND MATERIALS LIST	1
7.1 CONSUMABLE PARTS.....	1
APPENDIX	I
SAFETY INFORMATION	I
COMMON SOLVENT INFORMATION	II

Chapter 1 Introduction

1.1 Overview

EClassical 3270L Evaporative Light Scattering Detector (D3270L detector) is one of the EClassical 3200L series products launched by Elite Analytical Instruments Co., Ltd. As the detection unit of this series of high performance liquid chromatographs, it is used to detect the elution components in high performance liquid chromatography (HPLC), gel permeation chromatography (GPC), preparation of elution components in high performance liquid chromatography (HPLC), rapid chromatography system or counter current chromatography (CCC). It can be conveniently used with various liquid chromatography infusion pumps, automatic injector, chromatographic column incubator and other units.

The D3270L detector eliminates some common problems of other HPLC detectors, such as the differential detector is easily disturbed by the front peaks, which makes the analysis complicated, and the baseline is very unstable due to its extremely sensitive to temperature, which is incompatible with gradient elution. In addition, the response of differential detector is not as sensitive as that of ELSD. The low wavelength UV detector is often troubled by baseline drift under the condition of abrupt gradient, and the chromophore of the analyte is required. The D3270L detector is not subject to these restrictions. Different from these detectors, the D3270L detector can obtain a stable baseline even in the case of multi solvent gradient, which makes the resolution better and the separation speed faster. Besides, since the response of the D3270L detector does not depend on the optical properties of the sample, the sample detected by the D3270L detector does not require chromophores or fluorescent groups.

1.2 Principle

The D3270L detector consists of three independent steps: eluting solution atomization, solvent evaporation and component detection.

Atomization refers to the conversion of the elution solution into fine aerosols which enter the evaporation chamber to evaporate the solvent. The residual solute after solvent evaporation is irradiated by the light source. The scattered light generated by the irradiation is measured by a photomultiplier tube, which is related to the concentration of the sample components.

Atomization

The eluate from the mobile phase is atomized in the atomization chamber under the action of the inlet carrier gas, and then transformed into a small droplet aerosol, which makes the mobile phase easier to evaporate. The atomization stage is a very important step. The reliability and reproducibility of this step determine the sensitivity and reproducibility of the whole detector. The gas flow rate determines the atomization degree of the mobile phase and the size of the droplet, and the size of the droplet affects the difficulty of the mobile phase evaporation in the drift tube. When the fluidity of the mobile phase is poor (viscous liquid), the heating atomization method can be used to improve the atomization efficiency. Each method has an optimal gas flow rate to produce the best signal-to-noise ratio.

Evaporation of solvents

When the carrier gas transports the aerosol from the atomization chamber to the heated drift tube, the volatile components in the aerosol evaporate in the heated stainless steel drift tube. The appropriate drift tube temperature for a particular application depends on the composition and flow rate of the mobile phase, as well as the volatility of the sample. Compared with high water content flow, high organic content flow requires lower evaporation temperature. Low flow rate of the same mobile phase requires low temperature of the drift tube for evaporation. Low drift tube temperature is required for semi volatile samples to obtain the best sensitivity. The optimum temperature is determined by observing the signal to noise ratio at each temperature. Low evaporation temperature is very important to maintain the uniformity of particle size and the integrity of heat sensitive solute. Non volatile impurities in the mobile phase and atomized gas can cause noise. The use of high quality gases, solvents and volatile buffers (filtered) can significantly reduce baseline noise. If the mobile phase is not completely volatilized, the baseline noise will increase. Carefully select and set the parameters of the detector to ensure the complete volatilization of the mobile phase.

Test

The sample particles suspended in the mobile phase vapor enter the light scattering detection chamber from the evaporation tube. In the detection chamber, the sample particles scatter the light from the laser source, while the evaporated mobile phase does not. The scattered light is received by the photomultiplier tube (PMT) as the detector, and the generated electrical signal is transmitted to the signal output port, It is used for data acquisition (or digital signal acquisition) of analog input.

1.3 Performance specification

The performance specification of D3270L ELSD are follows:

Table 1-1 Performance Specification of D3270L detector

NO.	Items	Specifications
1	Detector	High sensitivity photomultiplier tube
2	Light source	30 MW, 650 nm high stability laser
3	Product level	Class 1 laser products
4	Sampling frequency	10Hz\20Hz\50Hz\100Hz
5	Temperature range of evaporation tube	Room temperature to 150 °C
6	Temperature range of atomizing nozzle	35 to 60 °C
7	Temperature regulation increment	1 °C
8	Accuracy of temperature control	±1 °C
9	Gas requirements	Clean air or nitrogen
10	Gas input pressure range	2 bar to 5 bar
11	Gas pressure measurement accuracy	0.01 bar
12	Gas flow accuracy	1%
14	Gas consumption	1.5~3 L/min
15	Eluent flow rate	0.01 ml / min to 3.0 ml / min
16	Minimum detection concentration	$\leq 5 \times 10^{-6}$ g/mL
17	Baseline noise	≤ 0.02 mV (methanol, 1 mL/min, default parameter)
18	Baseline signal drift	≤ 0.05 mV/30 min (methanol, 1 mL/min, default parameter)
19	Digital filter	Moving window digital filter, 10 gears to choose from, Default "5"
20	Sensitivity	6 gears to choose from, Default "1"
21	Analog signal output range	-1200 mV ~ 1200 mV, -2400 mV ~ 2400 mV
22	Quantitative repeatability (RSD ₇)	< 2.0 %
23	Zero adjustment control	Manual and automatic zero adjustment
24	Signal bias	-1,000 mV ~ 1,000 mV
25	Start low power consumption mode	Manual, remote automatic access to low power consumption
26	Correspondence	TCP



[Note]

- ◆ When the D3270L is applied in a preparative or semi-preparative scenario, the flow rate shunted to the D3270L should be less than 3.0 mL/min, so that the sample peak does not appear flat-headed. Excessive sample entering the detector may result in instrument failure or abnormal analytical results, etc.
- ◆ If the sample concentration is high or the injection volume is large and a flat-head peak appears, a low sensitivity block can be selected to reduce the response, thus avoiding or reducing abnormal failures of the instrument and experimental results due to an excessively high signal response.

1.4 Physical specifications

See table 1-2 for the physical specifications of D3270L detector.

Table 1-2 Physical Specifications of D3270L detector

NO.	Items	Specifications
1	Weight	16 Kg
2	Size (length× width× height)	600 mm×380 mm×260 mm
3	Power supply	84 ~ 265 VAC, 40 ~ 60 Hz
4	Power	250 VA

1.5 Appearance

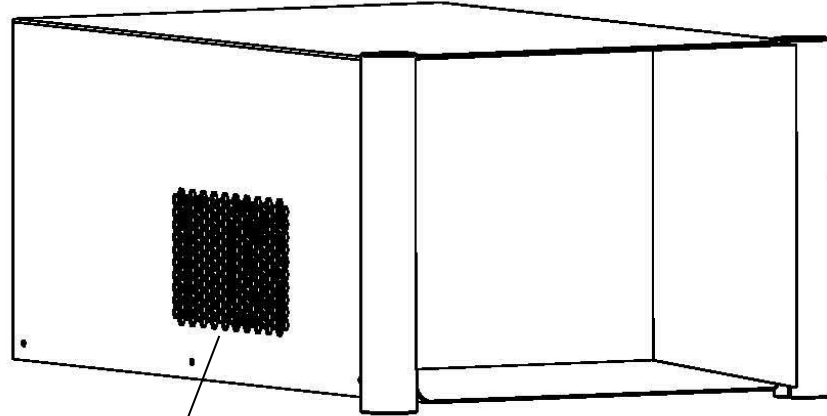
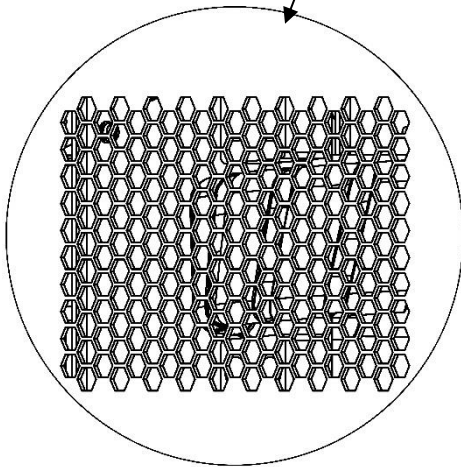

Fig 1-3 D3270L detector 3D stereogram



EMC honeycomb structure

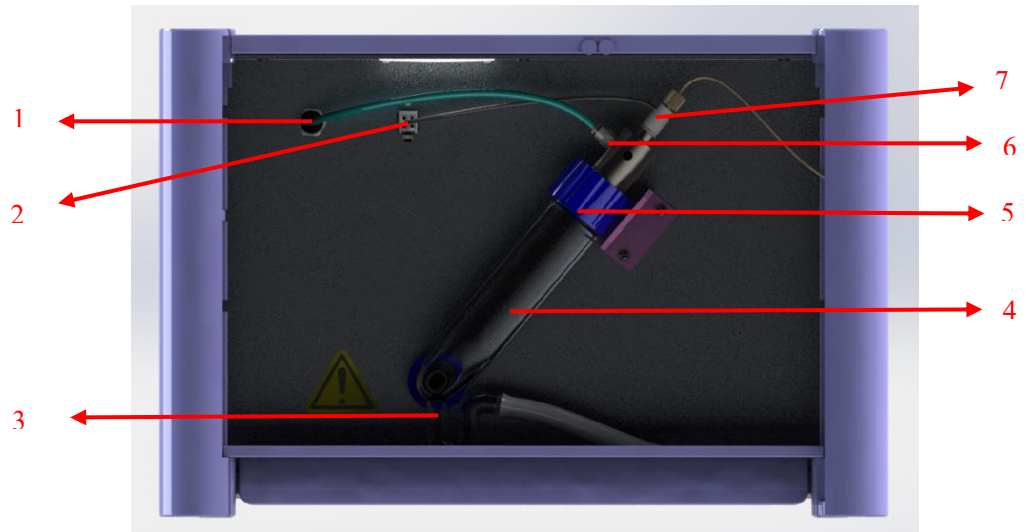

Fig 1-4 Schematic diagram of D3270L detector front liner

1. Tracheal joint;
2. Atomizer heating socket;
3. Atomizing pipe waste liquid pipe;
4. Atomizing tube;
5. Atomizer nozzle assembly;
6. Atomizer carrier gas interface;
7. Mobile phase interface.



[Warning] During transportation of used instrument, the fragile fittings such as "glass atomizing pipe" and other related fittings should be removed and properly packed to prevent damage or loss during transportation. In case of damage or loss caused by non-compliant transportation and use, our company is not responsible and reserves the right to claim compensation.

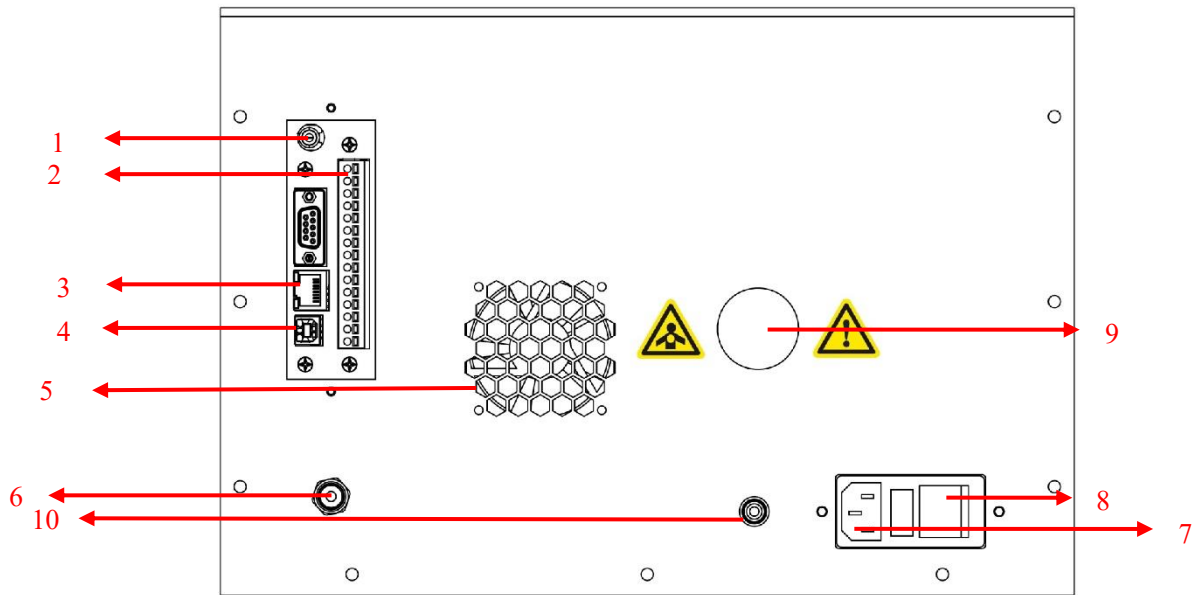

Fig 1-5 Schematic diagram of the D3270L rear liner

- 1. Analog signal output interface; 2. 15-pin connector; 3. Network cable interface; 4. USB interface; 5. Fans; 6. Gas supply interface; 7. Power outlets; 8. Power switch; 9. Exhaust gas exhaust port; 10. Grounding post.

Chapter 2 Installation and transportation

2.1 Unpacking acceptance

D3270L detector is wrapped in corrugated paper and plastic lining. After you receive the instrument, please first check whether the outer packaging of the instrument is complete and undamaged. If there are signs of damage in the outer packaging, please contact Park Jung Su Company or local distributor in time.



[Warning] If the instrument you receive shows signs of damage, please don't try to install and debug the instrument. You can ask ELITE to inspect and evaluate the condition of the instrument.

2.1.1 Unpacking

Place the box with D3270L detector face up on the horizontal ground. Cut off the top tape with wallpaper knife, and after opening the instrument package, make sure that the instrument is not connected with any cables or pipelines when taking out the instrument, and hold the bottom of the instrument with both hands when handling. For safety reasons, it is recommended that two people carry the instrument together to avoid personal injury. Sequentially removing foaming materials, Open the instrument protective film.

When handling the instrument, please handle the bottom edge of the instrument, not the upper edge of the atomization chamber.

2.1.2 Deliver checklist

Table 2-1 Deliver list of D3270L detector

NO.	Items	Unit	Quantity
1	D3270L Evaporative Light Scattering Detector	ea	1
2	D3270L Evaporative Light Scattering Detector Startup Package	set	1
3	Certificate	ea	1
4	Service Card	ea	1



[Note] If there are discrepancies between the packing list in the box and in the specification, please refer to the packing list in the box. It is subject to change without prior notice.

2.2 Stack Order

In order to guarantee the best working state of the instrument, it is recommended that the instruments should be stacked as shown in Fig 2-1.

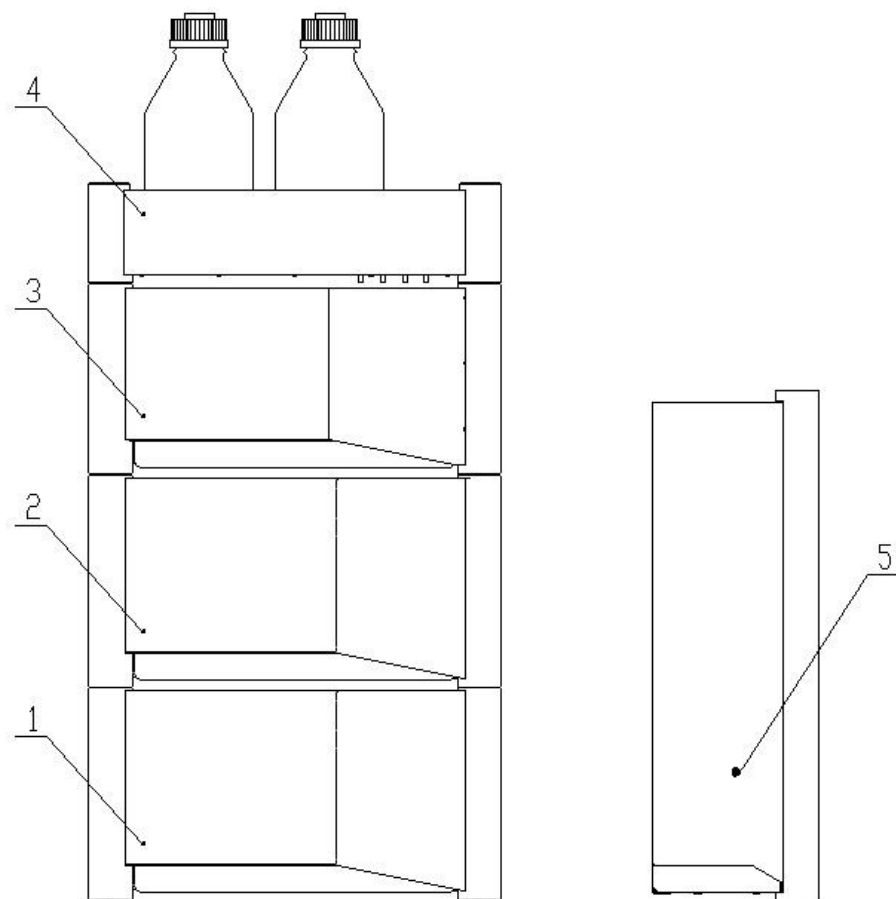

Fig 2-1 Recommended Stack Configuration for EClassical 3200L

1. Pump; 2. Autosampler; 3. Detector; 4. Solvent cabinet; 5. Column oven

2.3 Installation requirements

2.3.1 Site requirements

- **Environmental**

The detector should work under the environmental conditions described in Table 2-2. It is recommended that the ambient temperature change be less than 2 °C/h. If the ambient temperature fluctuates greatly, the collected signal may be affected.

Table 2-2 Environmental Requirements

NO.	Specifications	Requirements
1	Indoor use	The indoor environment should be clean and dust-free, free of inflammable and explosive materials, and well ventilated.
2	Electromagnetic field	There is no interference from electromagnetic noise sources nearby.
3	Maximum variation range of main power supply voltage	20 % rated voltage
4	Instantaneous overpressure level	II
5	Operating temperature range	5~30 °C
6	Relative humidity	20 %~80 %, no condensation



[Caution]

- ◆ **Do not use the detector under the condition of temperature fluctuation;**
- ◆ **If the ambient temperature is too low, please slowly raise the room temperature to avoid condensation inside the instrument caused by rapid temperature rise.**

- **Bench space**

D3270L detector can be placed on a normal desktop or experimental platform. If the complete EClassical 3200L system is to be placed on the workbench, it should be ensured that the workbench can bear the weight of all components, and an extra space of about 10 cm should be left on the left side, about 5 cm on the right side and about 15 cm on the back to facilitate air circulation and power cord connection.



[Caution]

- ◆ The detector should be far away from ventilation device or area with obvious temperature change. Please do not place the detector near the air conditioner outlet, window, microwave oven, etc.
- ◆ Avoid placing the instrument in a position with corrosive gas or excessive dust. This will reduce the performance of the instrument and shorten its service life.
- ◆ When placing the detector in the laboratory, make sure that the instrument power supply (electric coupler or power sockets) is always easy to switch on and off.



[Note]

- ◆ The detector should be placed close to the outlet of the chromatographic column to minimize the switch volume outside the column and improve the resolution of chromatographic separation.
- ◆ As a destructive detector, D3270L evaporative light scattering detector should be installed at the end of the chromatographic flow path or used with a splitter.



[Warning]

- ◆ The whole set of instruments should be placed in a horizontal position, otherwise there is a risk of falling!

- *Emission requirements*

Close to the detector, there should be a fume hood or other ventilation equipment to pump out the exhausted gas from the laboratory.

The black exhaust pipe (cuttable) of the detector should be connected to the fume hood or vent. If a vacuum device is used, make sure the speed is moderate to avoid turbulence in the glass siphon.



[Note]

- ◆ **Ensure that the sealing film on the exhaust pipe has been removed before installing the instrument.**
- ◆ **When installing the drain pipe (cuttable), make sure that the drain pipe is aligned with the waste bottle, so that the waste liquid can smoothly flow out from the drain pipe. In order to make the waste liquid in the drain pipe flow out smoothly, please connect a tee in series in the waste liquid pipe.**



[Warning]

- ◆ **Do not discharge gases to the laboratory. All accessories used should be disposed of according to the health and safety requirements stipulated by local regulatory authorities.**
- ◆ **The drain pipe must be connected to a suitable container (solvent characteristics should be considered). Users should disinfect or recycle all residues according to local environmental requirements.**

2.3.2 Power Line

To ensure the instrument can be normal and safe, please use a dedicated power line within the specified voltage range.

- Grounding, AC power supply 84 ~ 265 VAC/40 ~ 60Hz;
- Please choose T5AL250V fuse;



[Warning]

- ◆ **Please choose the special power cord provided by us. If you choose another brand or unknown power cord, it may cause damage to electronic components or personal injury!**
- ◆ **If the instrument is connected to a power grid higher than the applicable range, people may be shocked or the instrument may be damaged!**
- ◆ **Please unplug the power cord of the instrument before replacing the fuse to avoid electric shock.**
- ◆ **For personal safety and instrument protection, an external fuse is installed at the rear of the instrument.**

2.3.3 Gas requirements

The detector should be equipped with filtered, oil-free dry and clean gas (for example, N₂ or compressed air can be used when using aqueous mobile phase, and N₂ is recommended if the mobile phase is pure organic solvent).

Source: Please use pure and dry gas, preferably nitrogen, with the pressure adjusted to 4.5 ~ 5.5 bar (65 ~ 80 psi), and the purity of 99.9 % or more is better. The gas source can be a high-pressure gas cylinder or a gas generator.



[Note]

- ◆ **The pressure of the gas source should be less than 6.0 bar(87 psi) to avoid damaging the gas flowmeter inside the detector.**



[Warning]

- ◆ **Do not use gases that can burn with flammable solvents.**

2.4 Component connection

After meeting the above installation requirements, the D3270L ELSD still needs to install its related accessories to ensure the normal use of the instrument.

2.4.1 Gas connection

The gas inlet located on the back panel of the instrument is used to connect the external air source. In most cases, the optimal performance can be obtained when the input air pressure is 3 ~ 4 bar and the gas flow rate is 1.5 ~ 3 L / min.

The gas supply of the detector is connected to the air inlet in the lower left corner of the rear panel through a (6 mm Pu pipe), and the cut plastic pipe is tightly inserted into the quick connector. If an external filter is used, cut the Pu pipe according to the actual distance, connect the air source to the filter, and then connect the filter to the gas inlet at the rear of the instrument.

If it is necessary to remove the Pu pipe, make sure that the output pressure of the air source is zero to avoid accidents. When removing, hold the pipeline with one hand and push it in slightly. With the other hand, press and hold the black sealing ring of the two-way through plate at the gas input port and push it inward, and then pull out the gas input pipeline outward.



[Warning]

For safety reasons, when the instrument uses a high proportion of organic solvents, the operating gas must use inert gas, such as nitrogen. If mixed with oxygen or compressed air, it may cause explosion. The gas must be dry, clean and free of particles. It is recommended to install a gas filter between the gas source and the detector.

2.4.2 Exhaust pipe connection

Turn off the dust cover of the detection chamber on the back of the detector

anticlockwise and keep it well. Put the insect proof net (accessories) into the air outlet of the testing room, and then turn the corrugated pipe right angle elbow into the air outlet of the testing room clockwise, and press the insect proof net tightly. The outlet of the right angle elbow should face downward as far as possible, as shown in Fig. 2-2.

Insert one end of the black exhaust pipe (fitting) into the outlet of the right angle elbow, try to insert it to the bottom, and connect the other end to the fume hood or ventilation system or outdoor. Ensure that there is no low point in the pipeline to collect condensate. The exhaust pipe should not be too long, and the outlet of the exhaust pipe should be kept drooping.



[Note]

The exhaust pipe should not be too long, and the outlet of the exhaust pipe should be kept drooping.



[Note]

During the transportation of the detector, or when the detector is not used for a long time, take down the bellows right angle elbow and insect proof net, and screw on the dust cover of the detection chamber clockwise.

2.4.3 Atomization unit connection

Remove the parts from the package and remove all sealing film. Assemble the atomizing nozzle, atomizing glass tube and small locking cover of atomizing tube as shown in the Fig. Note that the two locking caps and glass atomizing tube should not be completely locked.

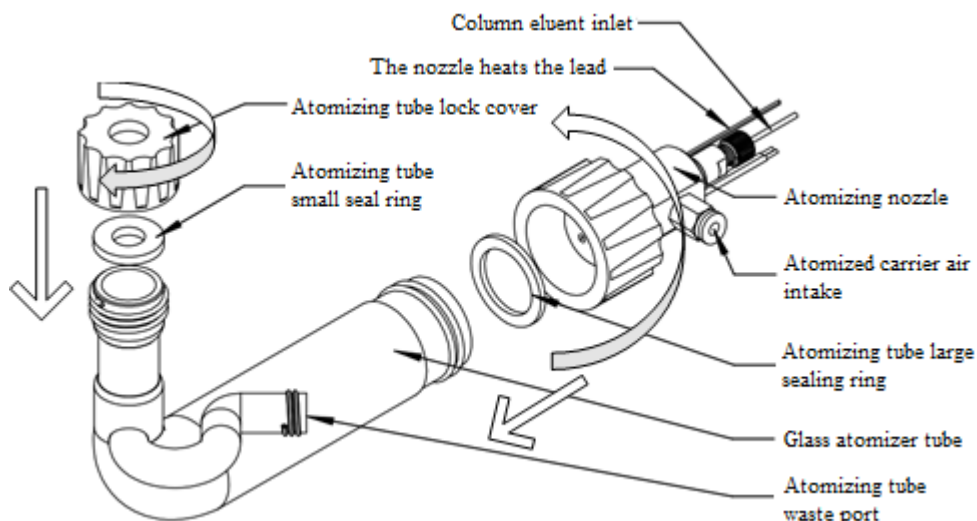

Fig. 2-2 Atomizing unit assembly diagram

Installation steps:

1. Take off the sealing film and protective cover at the inlet of evaporation pipe;
2. Put one end of the glass atomizing tube with a small locking cover on the evaporation tube through the hole on the small locking cover, gently push it into 1 ~ 2 cm, screw the small locking cover anticlockwise (from the perspective of the front of the instrument), push the glass atomizing tube into the bottom of the front cover after locking, and the end face of the small locking cover should be flush with the front panel;
3. The unconnected end of the overflow pipe of the atomization unit in the leakage tank is sheathed on the waste liquid outlet of the atomization pipe;
4. Turn the atomizing nozzle to make the inlet of the quick coupling of atomizing carrier gas face down, and then lock the locking cover of the atomizing nozzle;
5. Insert (4 mm) normal temperature gas pipe or atomizing gas heating gas pipe into carrier gas quick connector;

6. Connect the column outlet tube (1 / 16 "O.D.) to the liquid input port of the atomizing nozzle. The length of the connecting tube between the chromatographic column and the detector shall be as short as possible, and the inner diameter shall be as small as possible to avoid the peak diffusion. The pipeline shall be locked to the liquid input interface of atomizing nozzle with finger tight I peek connector or stainless steel connecting

screw.

7. Plug the heating lead plug of atomizing nozzle into the heating socket on the front panel;



[Warning]

During transportation of used instruments, fragile fittings such as "glass atomizing pipe" and other related fittings should be removed and properly packed to prevent damage or loss during transportation. In case of damage or loss caused by non-compliant transportation and use, our company is not responsible and reserves the right to claim compensation.

2.5 Communication connection

- 2 Communication management of EClassical 3200L system is completed by P3200L infusion pump, via LAN cables. Communication and power connection is shown as Fig. 2-3.

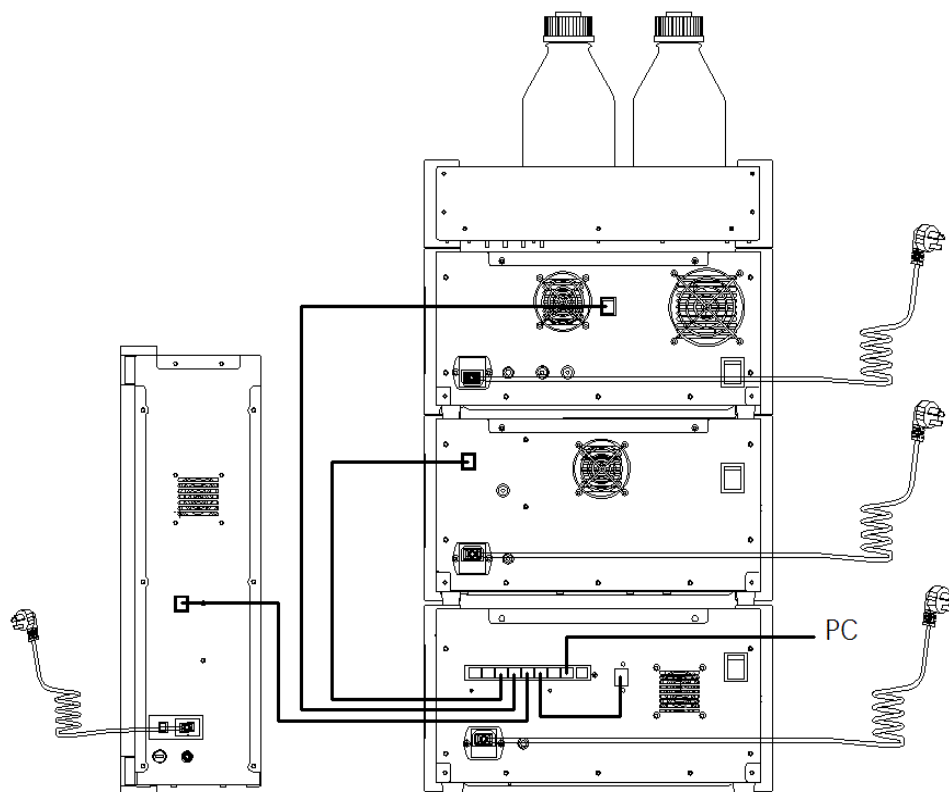

Fig 2-3 EClassical 3200L system communication

2.5.1 Circuit connection

For D3270L detector, please connect the circuit according to the following steps:

- 1) Lay the detector as Fig 2-1 and Fig 2-3.
- 2) Plug of each part of the power cord into the power input socket.

2.5.2 Communication connection

D3270L detector communication connection as follows::

- 1) Confirm that the power supply of D3270L detector and P3220L high pressure constant flow pump is OFF.
- 2) Connect the computer and “PC” port of P3200L with LAN cable.
- 3) Connect P3220L pump switch network port and D3270L detector network port with network cable.



[Note]

- ◆ **There are 8 yellow LAN ports in parallel on the switch of P3200L pump. Connect each module to the pump separately.**
- ◆ **Please select dedicated communication lines provided by Elite. Otherwise failed communication maybe happens.**
- ◆ **Under the condition of no pump, the router can be used instead.**

2.1 Pipeline and flow path connection

The pipeline and flow path connection of EClassical 3200L high performance liquid chromatograph can be referred to Fig. 2-4.

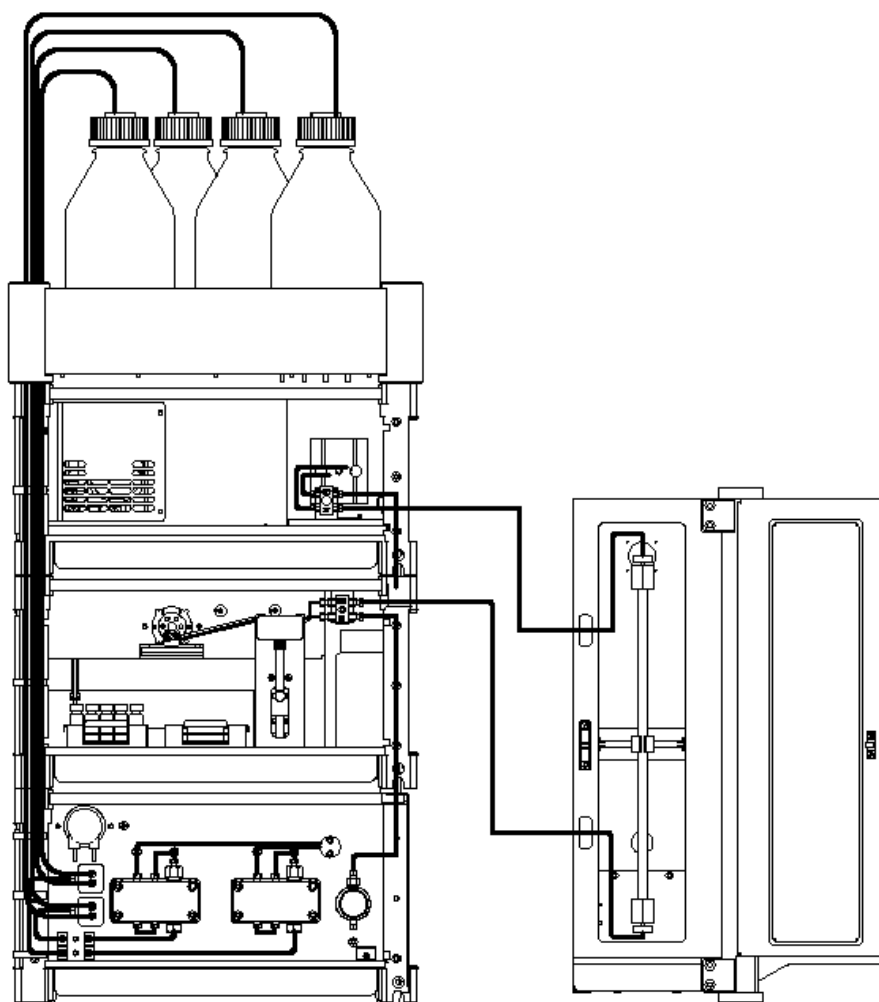

Fig 2-4 EClassical 3200L system flow connection

2.6.1 Pipeline connection

- ***Cutting tube***

Please use the special pipe cutter provided by the manufacturer to cut the stainless steel pipe into appropriate length, and the cutting surface should be even. Then bend back and forth until the pipe is cut off.



[Caution] Make the cutting surface of the pipe flush as much as possible to avoid birth and death volume. In addition, the inner diameter of the tube is not deformed, which causes the tube to be blocked.

- ***Connect the metal sealing ring***

The correct way of connecting screws and metal sealing rings for stainless steel pipes is shown in Fig 2-5 and 2-6.



[Caution] Please use the matching screw and blade ring. Stainless steel corresponds to stainless steel and peek corresponds to PEEK.

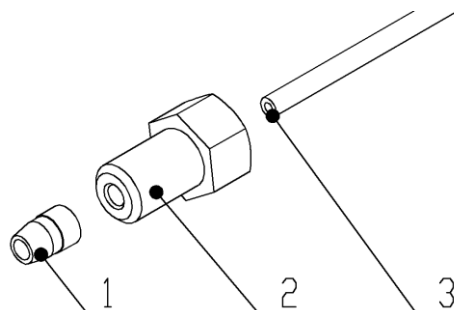

Fig. 2-5 Connection diagram

1. Metal sealing ring; 2. Stainless steel screw; 3. Stainless steel pipe

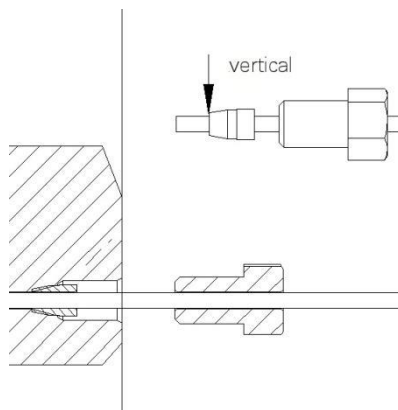

Fig. 2-6 Seal ring and tube



[Caution] Insert and touch the bottom of the opening, otherwise dead volume will be generated. The strength is subject to no leakage. Excessive force will cause screw damage.

2.6.2 Flow connection

Please follow the following steps to connect the flow path of EClassical 3200L system:

1) *Solvent filter cup assembly and infusion line connection*

Connect in order according to the label on the Fig

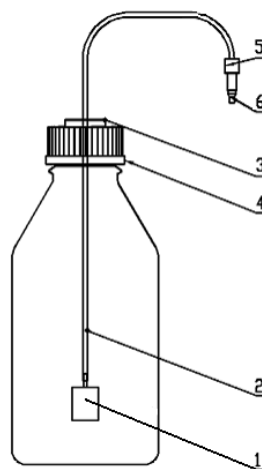

Fig 2-7 Solvent filter cup assembly and infusion pipeline connection

1. Solvent filter head; 2. Infusion tube; 3. Teflon stopper; 4. Bottle cap (with hole); 5. Solenoid valve connecting screw; 6. 1/8 "Omni-Lok Solenoid Valve blade ring

2) *Connection between liquid storage bottle and pump*

Connect the FEP infusion tube and solvent filter cup assembly provided with the instrument with the pump inlet as shown in Fig 2-8.

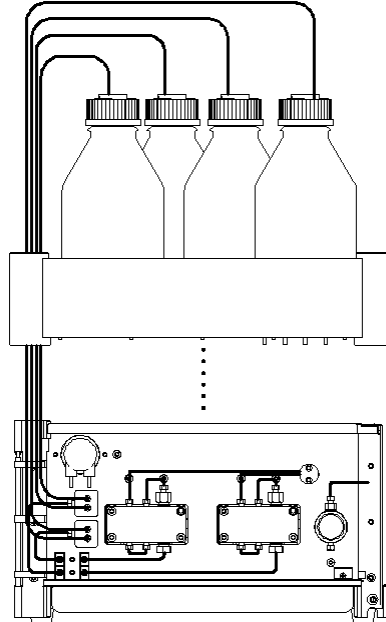

Fig 2-8 Connection diagram



[Note]

- ◆ The solvent filter assemblies should keep clean to avoid polluted..
- ◆ The liquid in the dissolving bottle must be degassed.
- ◆ Mobile phase must be filtered through 0.45- μ m mesh filter.

3) *Connection between pump outlet and sampler inlet*

Connect the outlet of the infusion tube from the pump with the inlet of the automatic sampler.

● **Pump outlet and manual sampling valve connection**

Connect the outlet of the pump to the inlet of injection valve (Port 2# is usually the inlet for the mobile phase on Rheodyne valve) with stainless steel tube (with screw connection and sealing edge ring). Port #3 of injection valve should be connected to the inlet of column as shown in Fig.2-9. .

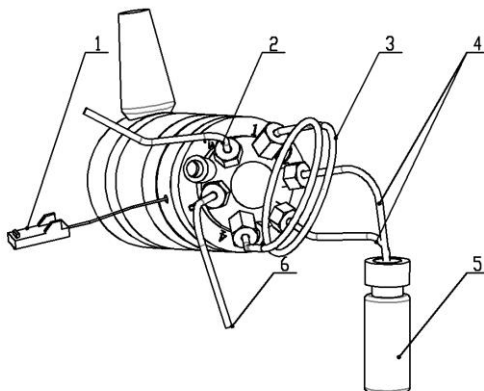

Fig 2-9 Flow connections for sample injection valve
 1. Automatic trigger interface; 2. Inlet of mobile phase; 3. Quantitative ring; 4. Waste liquid

● **Pump outlet and sampler connection**

Connect the outlet tubing from the pump to the inlet of the sampler as shown in Fig 2-10.

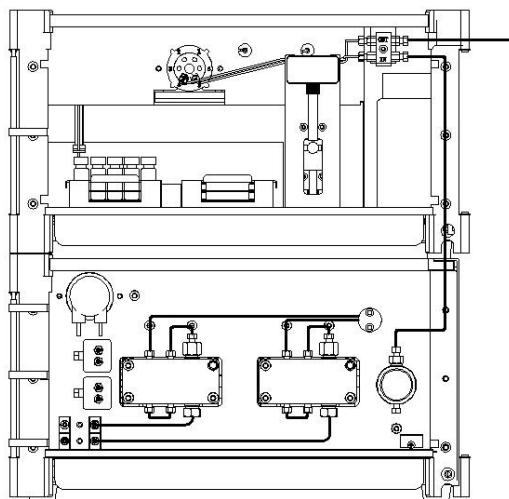

Fig 2-10 Connection between pump outlet and sampler

4) Sampler and column connection

The outlet of the sampler is connected with the inlet of the column, and the connection is shown in Fig 2-11.

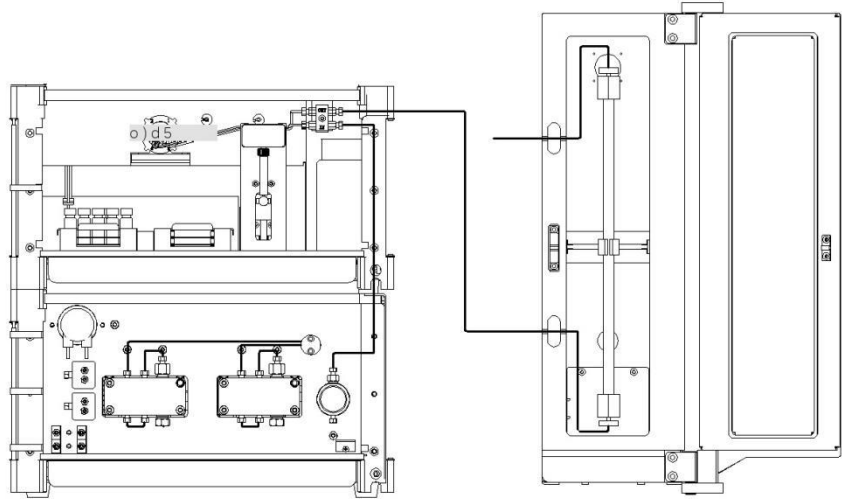

Fig 2-11 Connection between the outlet of sampler and column

5) Column and detector connection

The column and the detector connection is shown in Fig 2-12. The outlet of the column is connected to the inlet on the atomization pipe of the detector.

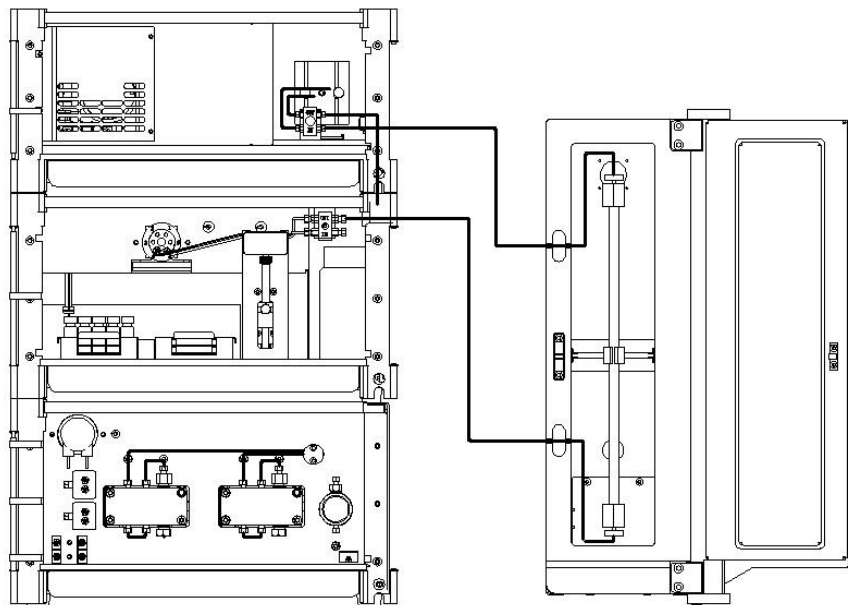

Fig 2-12 Connection between column and detector

6) Piston clean flow connection

Silicon tubing from clean solvent reservoir is connected to the inlet of peristaltic pump. The outlet of peristaltic pump is inserted into the Y-type connector of the system waste tubing, as shown in Fig 2-1.

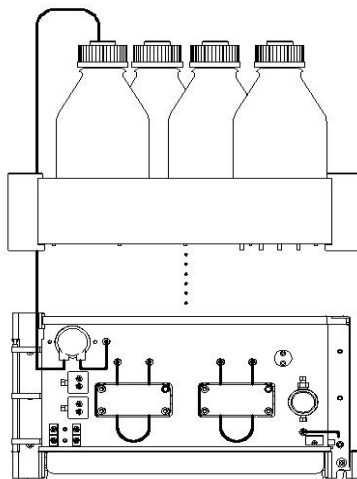

Fig 2-13 Plunger cleaning pipeline connection



[Note]

The solvent waste bottle should be place at a lower position with respect to the instrument.

7) Multi-channel body tubing connection

Multi-body is the system waste liquid collection place, including mobile phase waste, clean solvent waste, relief tubing waste, and unexcepted leakage. The outlet tubing from the multi-channel body is connected with the waste tubing of column oven by a Y-type connector. All waste is then discharged to the waste container.

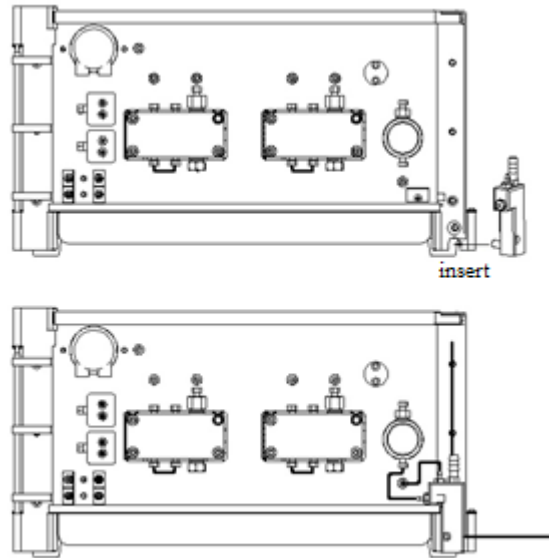
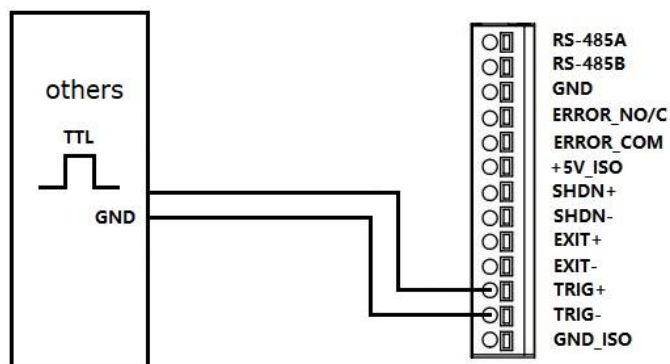

Fig 2-14 Multi-body pipeline connection

2.2 External trigger

1) Transistor transistor logic

Socket **11** TRIG+ is connected with external signal (+), **12** TRIG- connect to external signal ground (-).



2) Switching signal

Socket **6** +5 V_ISO is connected to a contact of an external switch, **11** TRIG+ is connecte to another contact of the external switch, **12** TRIG- and **13** GND_ISO is connected by short circuit.

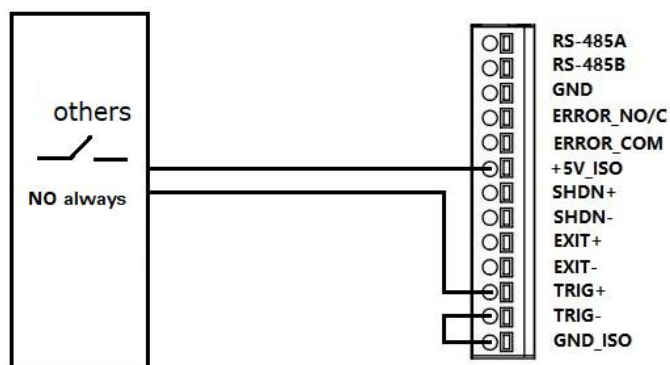

2.3 Preparation

New installed HPLC system and solvent pipes must be filled up with

mobile phase. If the system is normal phase, it is recommended to use isopropanol as drainage solvent, because it can be mixed with almost all HPLC solvents and has excellent wetting. If the system is an reverse phase system, methanol can be used as the filling solvent, and its operation is as follows:

- 1) Turn the vent valve handle to the open position.
- 2) Set the proportion of channels to be filled to 100 % and the flow rate to 10.000 mL/min.
- 3) Observe whether the solvent in the tube of channel A flows out along the tube. If not, use ear ball or syringe to suction at the liquid outlet until the liquid flows out.
- 4) Close the vent valve.
- 5) About 30 mL of methanol flows out of the pump outlet to remove residual bubbles.
- 6) Switch to another solvent channel and repeat steps 1) - 5).



[Caution]

During the process of connecting pipes, the solvent may leak from the pipe joint, and the operation of toxic and harmful reagents may endanger health. Please take protective measures.

2.4 Verification

In normal instance, the instrument customers received have been tested and came with verification. the performance met our requirements in factory. Users have no need to test and verify. If you have any doubt about the performance of the pump, verify it refer to the following steps:

- 1) Take a C18 chromatographic column with a size of 150 mm.
- 2) According to the default parameters of the detector in the

chromatographic data workstation, after fully balancing the system, continuously analyze 7 needles of 200 ppm cholesterol standard solution at a flow rate of 1.0 mL/min.

- 3) Get the chromatogram, calculate the qualitative and quantitative repeatability, and meet the factory indicators, that is, the whole liquid chromatography system meets the test requirements.

2.5 Transportation

D3270L detector is a precision instrument. Please handle it carefully when transporting over a long distance. Severe vibration and drop may damage the internal parts of the instrument. The random original packaging provided by Park Jung Su Company can effectively cushion the physical vibration of electronic parts and mechanical parts, and make the instrument get the best protection.

When the instrument needs to be transported or returned to the factory for maintenance, please pack it according to the following steps:

- 1) Turn off all instruments.
- 2) Pull out the power line and network cable of the detector and put it into the special sealing bag.
- 3) Remove the connecting pipeline between the detector and other unit components of the chromatograph.
- 4) Carefully remove the detector from the stacked configuration, place it on a wide platform and put it into a special sealing bag.
- 5) Put the original packaging foam into the detector frame and fix it.
- 6) Carefully put the fixed detector into the original packing box, and put other accessories together according to the delivery list.
- 7) Seal the mouth of the packing box with adhesive tape. In order to prevent liquid from entering, it is recommended to cover the sealed box with a layer of fresh-keeping film.
- 8) Transport the packaged instruments.



[Warning]

Before packing, please check the box, if the original packaging has been damaged, do not use it, you should consult your local dealer or Elite Analytical Instruments Co., Ltd. customer service staff to solve!



[Warning]

During transportation of used instrument, fragile fittings such as "glass atomizing pipe" and other relevant fittings should be removed and properly packed to prevent damage or loss during transportation. In case of damage or loss caused by non-compliant transportation and use, our company is not responsible and reserves the right to claim compensation.

3. Instrument operation

3.1 Power On and Off

Power on: Turn on the power switch(“I” means power on, “O” means power off), and the detector will enter into the power on self-test state. After the self-test is completed, the status indicator will also change from respiratory beat to blue, and the detector will enter the normal state of startup (if the process status indicator shows frequent flashing, If the detector fails to pass the self-test or leakage).

Shut down: Turn off the power switch, the instrument status indicator will be off, and the cooling fan will stop running. The whole machine is turned off.



[Warning]

Even if the power switch on the back panel of the detector is off, there is no power inside the instrument.If the power switch is not turned off and the power cord on the back panel of the instrument is pulled out directly, the power supply can also be cut off, but the process is illegal.



[Note]

The wavelength, output range and other parameters are the set values before the last shutdown. When the D3270L detector is run for the first time, all parameters are factory set default values.

3.2 Software installation

D3270L detector control software is divided into two types: Kromstation chromatography data workstation (including D3270L evaporative light scattering detector control module) and D3270L detector control module

Users of our EClassical 3200L chromatographic system can use the Kromstation (including the D3270L detector control module), which provides complete control of the instruments and evaporative light scattering detector in the system.

Other customers can use the D3270L detector control module to control the detector.

3.2.1 Computer Requirements

Hardware Requirements

- Minimum hardware requirements: Intel Core 2 CPU, 2G RAM, 1G hard disk (PDA module ; requires more than 8 G);
- Minimum display resolution: 1024×800, 64K color (16 bits true color) ;
- Others: at least two USB ports and one network port;
- Network management requirements: it is recommended that used to connect to the HPLC computer without internet connection. If it is necessary to connect to the internet, please complete the connection under the guidance of engineers from Elite Co., LTD.

Software requirement

- Kromstation workstation requires the operating system is Windows 10 or higher version of the operating system (such as Windows 10, 11) Windows.
- Confirmation for running Kromstation workstation's operating system for the original.
- Confirmation firewall closed
- Make computer operating systems "to sleep" option is set to "never".

- Set properties for the network adapter, identify the network adapter "power management" option in the "allow the computer to turn off this device to save power" in have not been selected.
- Computers used to connect to HPLC are not advised to install anti-virus software and touch other virus devices.

3.2.2 Computer Network IP Settings

Before installing the software, set up the computer network (take win10 OS as an example).

Right click the "Network" on the desktop and left click the "Properties".

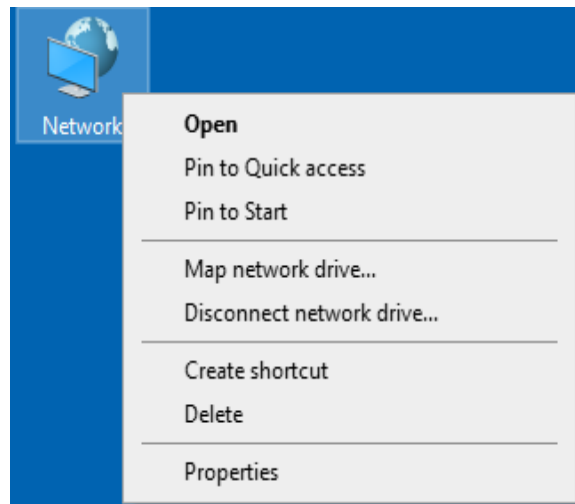

Fig.3-1 Set up Computer Network 01

After entering the “Network and Sharing Center” window, left click “Change Adapter Settings”.

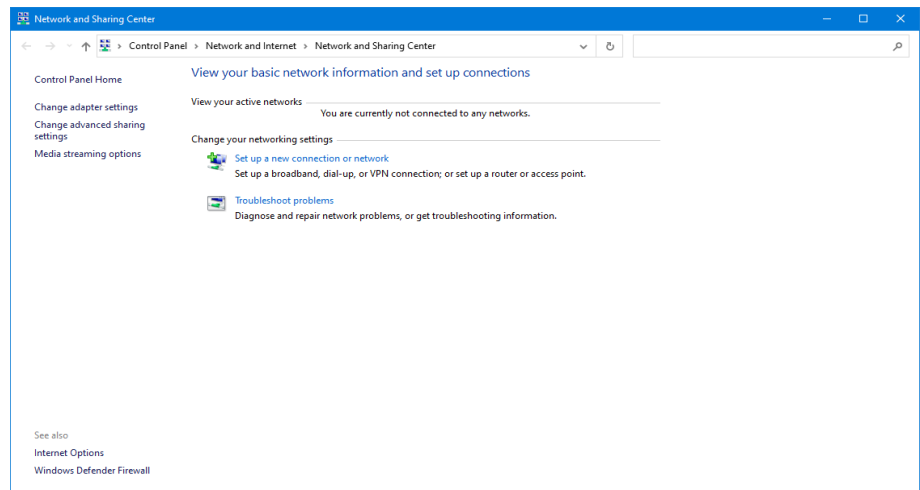

Fig.3-2 Set up Computer Network 02

After entering the “Network Connection Interface”, right click the “Ethernet” and left click the “Properties”.

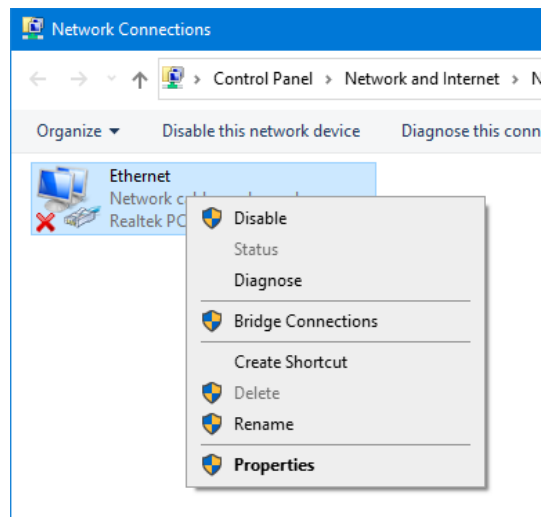

Fig.3-3 Set up Computer Network 03

Select the "Internet Protocol Version 4 (TCP/Ipv4)" into the "this connection uses the following items", and then click the "Properties".

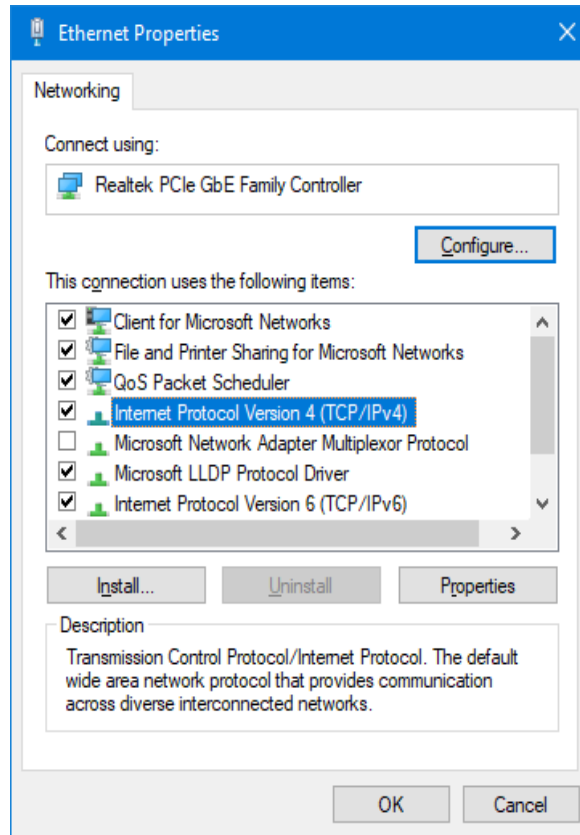

Fig.3-4 Set up Computer Network 04

After entering the "Internet Protocol Version 4 (TCP/Ipv4) Properties" dialog box, select the "Obtain an IP address automatically"

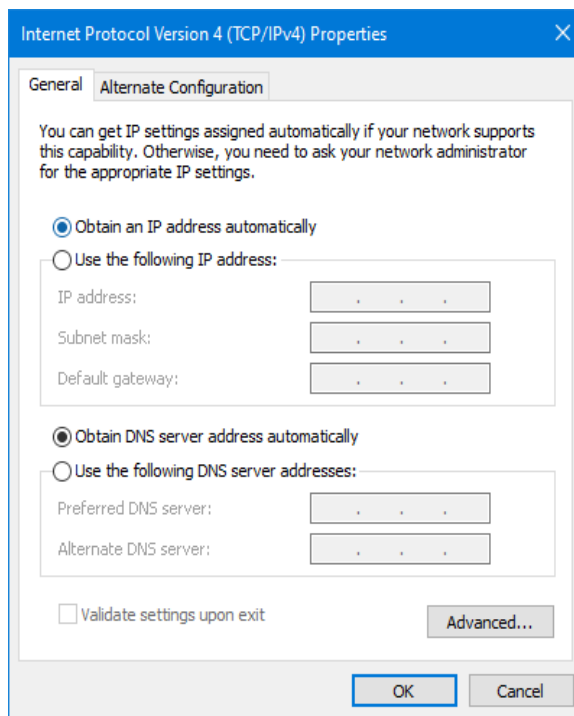

Fig.3-5 Set up Computer Network 05



【Note】

With LAN interface as the hardware communication mode, the client computer must be conFig with network communication card and corresponding driver.

3.2.3 Kromstation instal

For installation of the workstation, please refer to the instruction manual that comes with the Kromstation Chromatographic Data workstation software.

3.3 Workstation structure

All the methods and most functions of the detector can be realized by the control of chromatographic data workstation. Fig 3-6 shows the structure of the chromatographic data workstation.

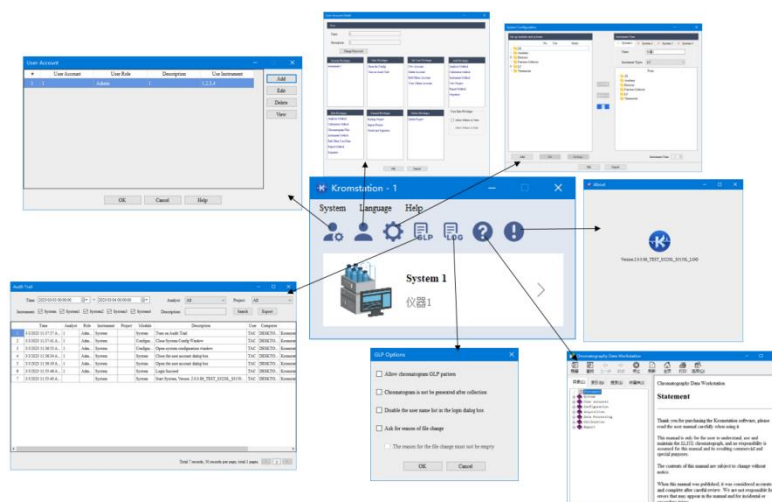

Fig.3-6 Kromstation workstation structure diagram

3.4 System Configuration

When using the D3270L detector, add the D3270L detector module on the configuration interface of the Kromstation workstation and enter the IP address of the instrument. The specific operations are as follows:

- 1) Click "Configuration Interface":

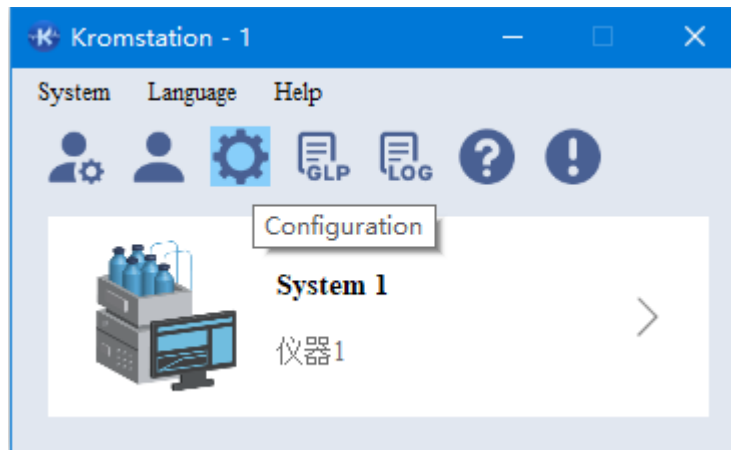

Fig.3-7 Configuration Interface 01

- 2) The system configuration interface is displayed. As shows in Fig 3-8:

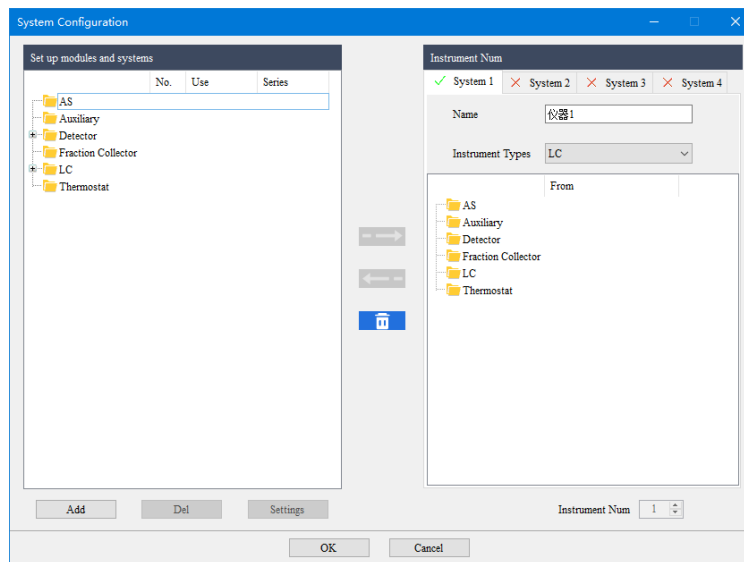

Fig.3-8 Configuration Interface 02

3) Click the "Add" button at the lower left corner of interface 3-8, and the interface as shown in Fig 3-9 will pop up:

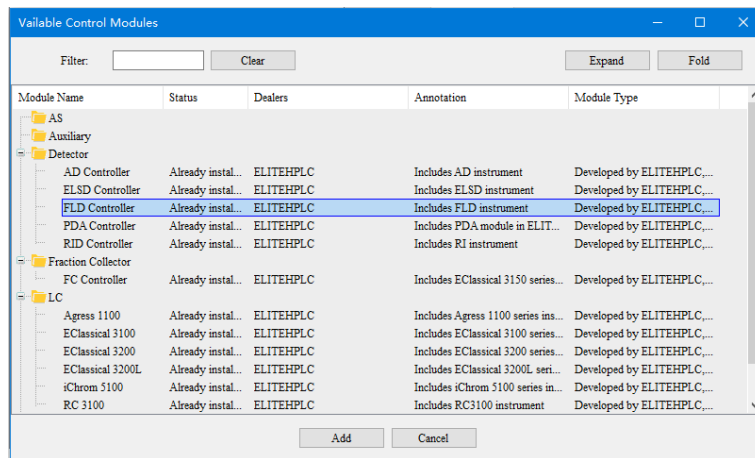

Fig.3-9 Configuration Interface 03

4) Select ELSD Controller, double-click to enter the configuration screen, and enter the IP address to verify the system

3.5 Main interface introduction

The control module related to the detector has two main parts:

1) *Device monitor window*

Under "Analysis" in the instrument interface window, "Device Monitor" is shown in Fig 3-10. Under this window, you can view the set instrument parameters, the parameters of the current operation of the instrument, the instrument status, etc. You can also send commands to the instrument through the control buttons in this interface, such as sending method, automatic return to zero, switching valves, etc.

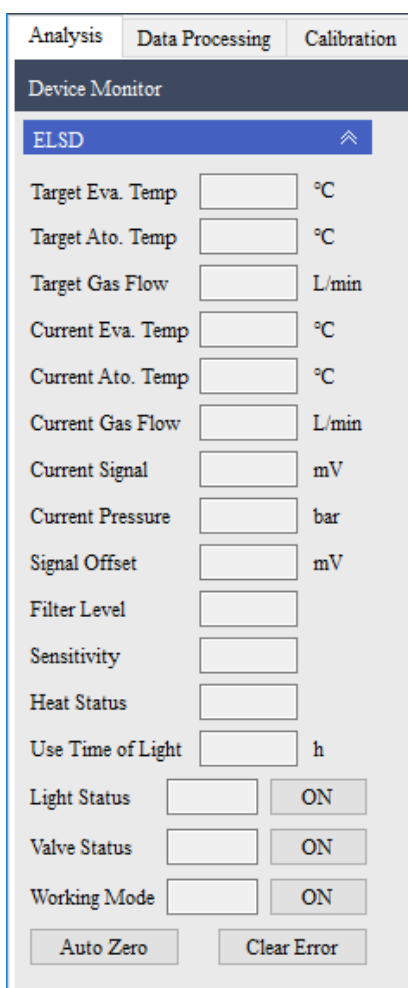

Fig 3-10 Device monitor window

2) Instrument method setting

Click "Instrument Method" to pop up the Instrument method setting dialog box, as shown in Fig 3-11. In the "Control Parameters" TAB, you can set evaporation temperature, atomization temperature, carrier gas flow rate, sensitivity, filtering level and other parameters.

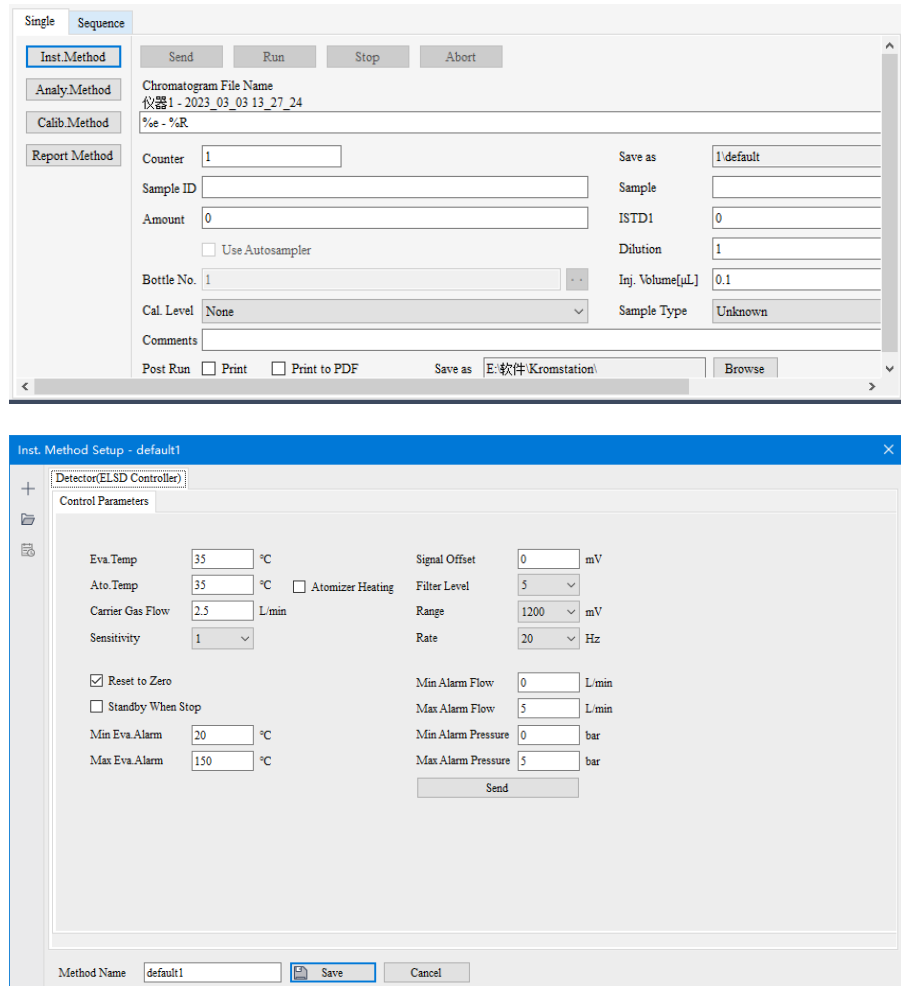

Fig. 3-11 Method setting surface



[Note]

You are advised to use the default parameters except the evaporation temperature.

3.6 Instrument preheating time

The purpose of preheating the detector is to make the parameters of the pump unit of the detector in the HPLC system reach a stable state before operation, such as evaporation temperature and carrier gas flow rate, so as to ensure the reliability of the test results and the service life of the instrument components.



[Note]

To reset to zero at stop is to make the detector enter the standby state after the collection is finished. It is not recommended to check this check box during continuous analysis.

3.7 Operation Method

After the detection method is set, click "Save" button to open the "Analysis" interface. Click "Send Method" button to send the current method to the detector and start the operation.

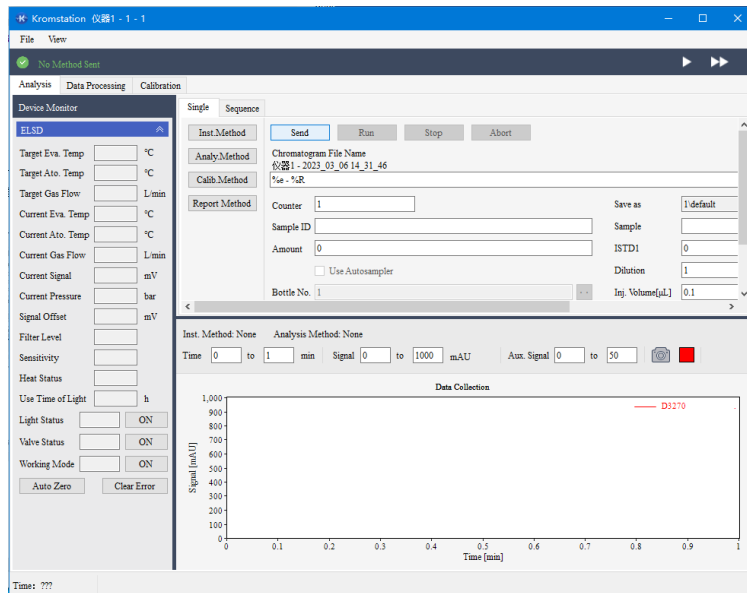

Fig. 3-12 Method Send surface

3.8 Baseline Auto Zero

Select "Analysis" in the system window, and click the "Auto Zero" button in the device monitor to reset the baseline automatically. As shown in Fig 3-12.

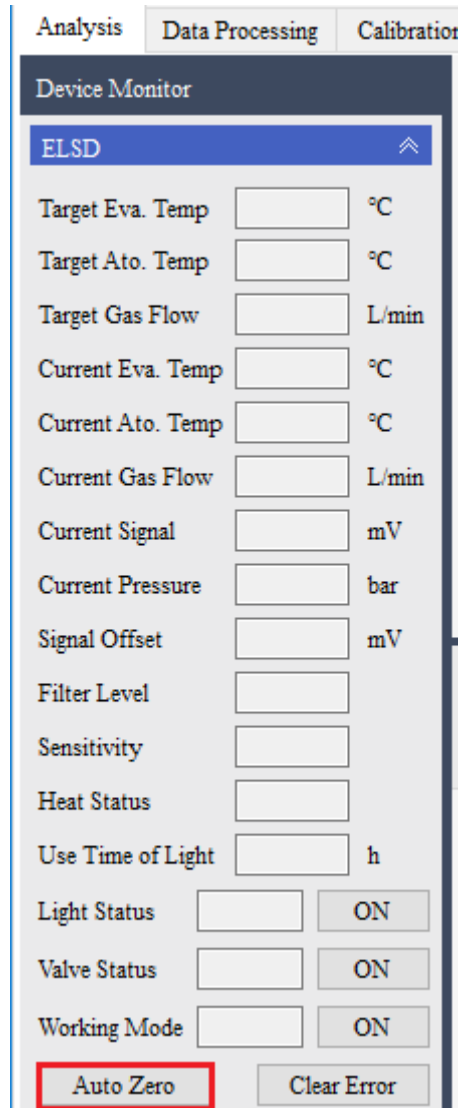

Fig. 3-13 Baseline auto zero

4. Handheld Controller Operation

4.1 Installation

First, according to the usage habits and site installation conditions, determine the position and orientation of the bracket installed on the instrument, and then refer to the random installation instructions of the hand-held controller to install the hand-held controller and bracket. Connect the hand-held controller with D3270L with "hand-held controller communication line". After connecting, the hand-held controller can be used when D3270L is turned on.

4.2 Key description of handheld controller

4.2.1 Set evaporation temperature

```
► 1 . S e t   T e m p .  
   2 . S e t   F l o w
```

```
S e t   T e m p .  
V a l u e = 4 0
```

- 1) In non MENU mode, press MENU to enter MENU mode
- 2) Press ▲、▼ to main MENU item 1. Set temp
- 3) Press OK to enter the MENU item
- 4) Press ▲、▼ to increase or decrease data, and press ◀、▶ to switch data bits (evaporation temperature depends on actual chromatographic eluent)
- 5) Press OK to confirm and the MENU will return to the main MENU automatically

6) Press the MENU key to exit the MENU mode

The evaporation temperature is set in the range of 20 ~ 150 °C. The actual control temperature range is room temperature to 150 °C. Because the evaporator does not have refrigeration capacity, when the set temperature is less than room temperature, the temperature controller will not work.

4.2.2 setting carrier gas flow

```

▶ 2 . S e t   F l o w
   3 . S e t   N o z z l e
    
```

```

S e t   F l o w
V a l u e = 3 . 0 0
    
```

- 1) In non MENU mode, press MENU to enter MENU mode
 - 2) Press ▲、▼ to go to the main MENU item 2. Set flow
 - 3) Press OK to enter the MENU item
 - 4) Press a ▲、▼ to increase or decrease data, and press ◀、▶ to switch data, and the data is usually set between 2.00 and 3.00 (the optimal pressure of the atomizing nozzle is about 2.2 bar.)
 - 5) Press OK to confirm and the MENU will return to the main MENU automatically
 - 6) Press the MENU key to exit the MENU mode
- So far, the carrier gas flow is set successfully, and the setting range of carrier gas flow is 0 ~ 5.00 L / min.

4.2.3 set atomizing nozzle for heating

```
▶ 3 . S e t   N o z z l e
   4 . S e t   S e n s .
```

```
▶ O N / O F F           O F F
   N o z z l e   T e m p .
```

```
N o z z l e   T e m p .
V a l u e = 3 5
```

- 1) In non MENU mode, press MENU to enter MENU mode
- 2) Press ▲、▼ main MENU item 3. Set nozzle
- 3) Press OK to enter the MENU item
- 4) Press ▲、▼ to select the submenu ON/OFF. The current switch status is displayed after the submenu on / off
- 5) Press OK to enter the submenu on / off
- 6) Press and key to select on to turn on the nozzle heating function
- 7) Press the OK key to confirm the input options and automatically exit the submenu on / off
- 8) Press and key to select the submenu "silent temp"
- 9) Press the OK key to enter the submenu "nozzle temp"
- 10) Press ▲、▼ to increase or decrease the temperature data, and press ◀、▶ Switchable data bits
- 11) Press the OK key to confirm the input data, and automatically exit from the submenu "nozzle temp"
- 12) Press ESC to return to the main MENU

13) Press the MENU key to exit the MENU mode

So far, the heating function of atomizing nozzle is successfully started. The heating temperature range of atomizing nozzle is 35 ~ 60 °C. After the heating function of atomizing nozzle is turned on, in the working mode, a small box will be displayed at the lower position behind the display screen to indicate that the heating function of atomizing nozzle is on.

T = 40 ■	F = 3.00
P = 3.80	S = 10

4.2.4 setting sensitivity

```
▶ 4 . Set Sens .
  5 . Set Offset
```

```
Set Sens .
Value = 3
```

- 1) In non MENU mode, press MENU to enter MENU mode
- 2) Press ▲、▼ key to main MENU item 4. Set sens
- 3) Press OK to enter the MENU item
- 4) Press ▲、▼ to increase or decrease data, and press ◀、▶ Switchable data bits
- 5) Press OK to confirm and the MENU will return to the main MENU automatically
- 6) Press the MENU key to exit the MENU mode

The sensitivity setting range is 1 ~ 6. The sensitivity of the detector increases with the increase of the number. The default value is 3.



[Note]

The sensitivity setting function works for all models of digital outputs and for specific models of analog outputs.

4.2.5 Setting bias voltage

```
▶ 5 . Set Offset
  6 . Set Scale
```

```
Set Offset
Value = 0
```

- 1) In non MENU mode, press MENU to enter MENU mode
- 2) Press ▲、▼ to main MENU item 5. Set offset
- 3) Press OK to enter the MENU item

4) Press ▲、▼ to increase or decrease data, and press ◀、▶ Switchable data bits

5) Press OK to confirm and the MENU will return to the main menu automatically

6) Press the MENU key to exit the menu mode

At this point, the bias voltage is successfully set to 10 mV, and the signal output is the original signal voltage + 10 mV bias voltage. The setting range of bias voltage is - 1000 mV ~ 1000 mV, and the default value is 0 mV.



[Note]

Bias voltage may cause additional noise. The best performance of the instrument is measured at a bias voltage of 0 mV.



[Note]

The signal bias function works for all models of digital output and for specific models of analog output

4.2.6 Setting output range

```
▶ 7 . Set Range
  8 . Set Rate
```

```
Set Range
▶ 1200mV
```

- 1) In non menu mode, press MENU to enter menu mode
- 2) Press ▲、▼ to main MENU item 7. Set range
- 3) Press OK to enter the menu item
- 4) Select 1200 mV or 2400 mV by pressing and key
- 5) Press OK to confirm and the to the main menu automatically
- 6) Press the MENU key to exit the menu mode



[Note] The output range adjustment function number digital output has effect, and it has effect on specific model analog output.

4.2.7 Setting the sampling frequency

```
▶ 8 . Set Rate
  9 . Set Filter
```

```
Set Rate
▶ 20Hz
```

- 1) In non menu mode, press MENU to enter menu mode
- 2) Press ▲、▼ to main menu item 8. Set rate
- 3) Press OK to enter the menu item
- 4) Select 10Hz, 20Hz, 50Hz or 100Hz by pressing the + and key
- 5) Press OK to confirm and will return to the main menu automatically
- 6) Press the MENU key to exit the menu mode

4.2.8 Set filter

```
▶ 9 . Set Filter
 10 . Set LED
```

```
Set Filter
Value=10
```

- 1) In non menu mode, press MENU to enter menu mode
- 2) Press ▲、▼ keys to the main menu item 9. Set Filter.
- 3) Press OK to enter the menu item
- 4) Press ▲、▼ to increase or decrease data, and press ◀、▶ Switchable data bits

5) Press OK to confirm and the MENU will return to the main menu automatically

6) Press the MENU key to exit the menu mode

The filter range is 1~10, and the filtering function of the instrument on the signal is enhanced with the increase of the number.



[Note] The filter function has an effect on all types of digital output and on specific types of analog output.

4.2.9 Set the startup to zero.

```
▶ 12 . Startup Az
  13 . Output Cfg .
```

```
Startup Az
▶ NO
```

1) In non menu mode, press MENU to enter menu mode

2) Press ▲、▼ to the main MENU item 12. Startup Az

3) Press OK to enter the menu item

4) Press ▲、▼ keys to select NO or YES.

5) Press OK to confirm and the menu will return to the main menu automatically

6) Press the MENU key to exit the menu mode



[Note] Starting the zeroing function is effective for all models of digital output and for specific models of analog output.

4.2.10 Set the output function

```

▶ 13 . Output Cfg .
  14 . Temp . Alarm
    
```

```

Output Cfg .
▶ On Error
    
```

- 1) In non menu mode, press MENU to enter menu mode
- 2) Press ▲、▼ to the main menu item 13. Output Cfg.
- 3) Press OK to enter the MENU item
- 4) Press ▲、▼ to select On Error, On Start or On Standby.
- 5) Press OK will return to the main menu automatically
- 6) Press the MENU key to exit the menu mode

4.2.11 Setting temperature alarm

```

▶ 14 . Temp . Alarm
  15 . Flow Alarm
    
```

```

▶ ON/OFF      OFF
  Min Temp .
    
```

```

▶ Min Temp .
  Max Temp .
    
```

```

Min Temp .
Value = 50
    
```

```

Max Temp .
Value = 100
    
```

- 1) In non menu mode, press MENU to enter menu mode
- 2) Press ▲、▼ to the main MENU item 14. Temp Alarm.
- 3) Press OK to enter the MENU item
- 4) Press ▲、▼ to select ON/OFF The current switch status is displayed after the submenu ON/OFF
- 5) Press the OK key to enter the submenu ON/OFF.
- 6) Press ▲、▼ to select ON or OFF to turn on or off the temperature alarm.
- 7) Press the OK to confirm the input options and automatically exit the submenu ON/OFF.
- 8) Press ▲、▼ to select the submenu Min Temp.
- 9) Press OK to enter the submenu Min Temp.
- 10) Press ▲、▼ to increase or decrease the temperature data, and press ◀、▶ Switchable data bits
- 11) Press the OK key to confirm the input data, and automatically exit the submenu Min Temp.
- 12) Press ▲ and ▼ to select the submenu Max Temp.
- 13) Press OK to enter the submenu Max Temp.
- 14) Press ▲、▼ to increase or decrease the temperature data, and press, to switch the data bits, for example, set the data to 100.
- 15) Press OK to confirm the input data and automatically exit the submenu Max Temp.
- 16) Press ESC to return to the MENU.

17) Press the MENU key to exit the MENU mode.

The low temperature alarm temperature is 50°C, and the high temperature alarm temperature is 100°C. Operating mode, when the temperature of the evaporation chamber exceeds this range, an alarm event - sound will be triggered. When the buzzer sounds and the display shows the evaporation temperature signal value, the rear position will show ▲ or ▼ to indicate whether it is a high temperature alarm (▲) or a low temperature alarm (▼). At this time, you can temporarily turn off the alarm by pressing the ESC key until you re-enter the working mode next time.

T = 140	▲	F = 3.00
P = 3.80		S = 10

T = 30	▼	F = 3.00
P = 3.80		S = 10



[Note The setting range of low temperature alarm temperature is 20 ~ 150°C, and the default is 20°C; The setting range of high temperature alarm temperature is 20 ~ 150°C, and the default is 150°C. Please ensure that the low temperature alarm temperature is lower than the high temperature alarm temperature, otherwise the setting is invalid. When entering the working mode, it will take some time for the temperature to remain stable, so the alarm will take effect after about 1 minute to avoid false alarm.

4.2.12 Set the flow alarm.

```

▶ 15 . F l o w   A l a r m
   16 . P r e s s .   A l a r m

```

```

▶ ON / OFF           OFF
   M i n   F l o w

```

```

▶ M i n   F l o w
   M a x   F l o w

```

```

M i n   F l o w
V a l u e = 1 . 0 0

```

```

M a x   F l o w
V a l u e = 3 . 5 0

```

- 1) In non menu mode, press MENU to enter menu mode
- 2) Press ▲、▼ to the main MENU item 15. Flow Alarm.
- 3) Press OK to enter the MENU item.
- 4) Press ▲、▼ to select the submenu ON/OFF, and the current switch state is displayed behind the submenu ON/OFF.
- 5) Press OK to enter the submenu.
- 6) Press ▲、▼ to select ON or OFF to turn on or off the carrier gas flow alarm.
- 7) Press the OK key to confirm the input options and automatically exit the submenu.
- 8) Press▲、▼ to select the submenu Min Flow.
- 9) Press OK to enter the submenu.
- 10) Press ▲、▼ to increase or decrease data, and press, to switch data bits.
- 11) Press the OK key to confirm the input data and automatically exit the submenu.

- 12) Press ▲、▼ to select the submenu Max Flow.
- 13) Press OK to enter the submenu.
- 14) Press ▲、▼ to increase or decrease data, and press, to switch data bits.
- 15) Press the OK key to confirm the input data and automatically exit the submenu.
- 16) Press ESC to return to the MENU
- 17) Press the MENU key to exit the MENU mode.

The lower limit of low flow alarm flow is 1.00 L/min, and the upper limit of high flow alarm flow is 3.50 L/min. When the carrier gas flow exceeds this range, the instrument will make an alarm sound: The buzzer sounds and ▲ or ▼ will be displayed at the position behind the carrier gas flow signal value on the display screen to indicate whether it is a high flow alarm (▲) or a low flow alarm (▼). At this time, you can temporarily turn off the alarm by pressing the ESC key until you re-enter the working mode next time.

T = 40	F = 4.00 ▲
P = 3.80	S = 10

T = 40	F = 0.50 ▼
P = 3.80	S = 10



[Note] The setting range of low-flow alarm flow is 0 ~ 5.00 L/min, and the default is 0 L/min; The setting range of high-flow alarm flow is 0 ~ 5.00 L/min, and the default is 4.00 L/min.

4.2.13 Setting pressure alarm

```
▶ 16 . P r e s s . A l a r m
  17 . L e a k A l a r m
```

```
▶ ON / OFF      OFF
  M i n P r e s s .
```

```
▶ M i n P r e s s .
  M a x P r e s s .
```

```
M i n P r e s s .
V a l u e = 1 . 0 0
```

```
M a x P r e s s .
V a l u e = 4 . 0 0
```

- 1) In non MENU mode, press MENU to enter menu mode
- 2) Press ▲、▼ to the main MENU item 16. Press Alarm.
- 3) Press OK to enter the MENU item
- 4) Press ▲、▼ to select the submenu ON/OFF. The current switch status is displayed after the submenu on / off
- 5) Press OK to enter the submenu.
- 6) Press ▲、▼ to select ON or OFF to turn on or off the carrier gas flow alarm.
- 7) Press OK to confirm the input options and automatically exit the submenu.
- 8) Press ▲、▼ to select the submenu Min Press.
- 9) Press OK to enter the submenu.
- 10) Press ▲、▼ to increase or decrease data, and press ◀、▶ to switch data bits.
- 11) press OK to confirm the input data and automatically exit the submenu.
- 12) Press ▲、▼ to select the submenu Max Press.
- 13) Press OK to enter the submenu.

14) Press ▲、▼ to increase or decrease data, and press to switch data bits.

15) Press OK to confirm the input data and automatically exit the submenu.

16) Press ESC to return to the MENU

17) Press MENU to exit the menu mode.

The lower limit of pressure for low pressure alarm is 1.00 bar, and the upper limit of pressure for high pressure alarm is 4.00 bar. When it exceeds this range, an alarm will be issued. The buzzer sounds and ▲ or ▼ will be displayed at the position behind the carrier gas pressure signal value on the display screen to indicate whether it is a high pressure alarm (▲) or a low pressure alarm (▼). At this time, you can temporarily turn off the alarm by pressing the ESC key until you re-enter the working mode next time.

T = 40	F = 3.00
P = 5.00 ▲	S = 10

T = 40	F = 3.00
P = 0.50 ▼	S = 10



[Note] The setting range of low pressure alarm pressure is 0 ~ 5.00 bar, and the default value is 0 bar; The setting range of high pressure alarm pressure is 0 ~ 5.00 bar, and the default is 5.00 bar. Please make sure that the low pressure alarm pressure is less than the high pressure alarm pressure, otherwise the setting is invalid. When entering the working mode, it will take some time for the carrier gas pressure to remain stable, so the alarm will take effect after about 1 minute to avoid false alarm.

4.2.14 Set the communication mode

▶ 18 . Com Mode
19 . Save Set

```

▶ Mode          RS - 232
Set Com
    
```

```

Mode          RS - 232
▶ RS - 232
    
```

```

▶ Rate          9600bps
DHCP           Enable
    
```

```

Rate          9600bps
▶ 9600bps
    
```

```

▶ DHCP          Enable
IP
    
```

```

DHCP          Enable
▶ Enable
    
```

```

IP
192.168.    0.    6
    
```

- 1) Press MENU in non-menu mode to enter menu mode.
- 2) Press ▲、▼ to the main menu item 18. Set Com.
- 3) Press OK to enter the MENU item.
- 4) Press ▲、▼ to select the submenu Mode, and the current communication Mode is displayed behind the submenu mode.
- 5) Press OK to enter the submenu.
- 6) Press ▲、▼ to select the communication mode.
- 7) Press OK to confirm the input options and automatically exit the submenu.
- 8) Press ▲、▼ to select the submenu Set Com.

- 9) Press OK to enter the submenu.
- 10) Press ▲、▼ to select the secondary submenu Rate, and the current communication rate is displayed behind the Rate.
- 11) Press OK to enter the secondary submenu.
- 12) Press ▲、▼ to select one of the three communication rates of 9600 bps, 19200 bps, 38400 bps.
- 13) Press the OK key to confirm the input options and automatically return to the secondary submenu.
- 14) Press ▲、▼ to select the secondary submenu DHCP.
- 15) Press OK to enter the secondary submenu.
- 16) Press ▲ and ▼ to select Enable to start DHCP to automatically acquire IP, or Disable to use the set static IP address.
- 17) Press OK to confirm the input options and automatically return to the secondary submenu.
- 18) Press ▲、▼ to select the secondary submenu IP.
- 19) Press OK to enter the secondary submenu.
- 20) Press▲, ▼ to increase or decrease data, and press, to switch data bits.
- 21) Press OK to confirm the input options and automatically return to the secondary submenu.
- 22) Press ESC to return to the first-level submenu.
- 23) Press ESC to return to the main MENU

- 24) Press MENU to exit MENU mode.

TCP and HTTP communication modes need to set IP addresses, which range from class C IP segment 192.0.0 to 223.255.255.255, and the default IP address is 192.168.0.6. When DHCP is Enable, the IP address set manually is invalid, and the IP displayed at this time is the IP address

obtained automatically.



[Note] Modifying the communication mode will take effect after the instrument is restarted.

4.2.15 Storage method

```
▶ 19 . Save Set
  20 . Load Set
```

```
Save Set
Value = 1
```

- 1) In non MENU mode, press MENU to enter MENU mode
- 2) Press ▲ and ▼ to the main MENU item 19. Save Set.
- 3) Press OK to enter the MENU item.
- 4) Press ▲、▼ to increase or decrease data, and press, to switch data bits.
- 5) Press OK to confirm, and the MENU will automatically return to the main MENU.

- 6) Press the MENU key to exit the MENU mode.

The items set through the MENU at this point will be stored, which are still valid after the power of the instrument is turned off, and can be remembered after the next power-on, and can be called by the user at any time. The storage location range is 1 ~ 10, and the default is position 1.

The storage procedure will overwrite that original data in the storage location. The storage contents are as follows:

Serial number	Content
1	evaporation temperature
2	Carrier gas flow
3	Nozzle temperature control switch
4	Nozzle temperature
5	Detector sensitivity
6	Signal bias
7	Signal scaling
8	Signal zero value
9	Temperature alarm switch
10	High temperature alarm value
11	Low temperature alarm value
12	Flow alarm switch
13	High flow alarm value
14	Low flow alarm value
15	Pressure alarm switch
16	High pressure alarm value
17	Low pressure alarm value
18	Leakage alarm switch
19	Leakage alarm sensitivity
20	Communication mode
21	Communication rate
22	Network IP address

In addition to 10 groups of method storage spaces that can be freely stored and called, the instrument also implies a storage space to be called when the machine is turned on. This space stores the user's operations in the MENU, so that the last working method can be remembered every time the machine is turned on. It should be noted that in order to avoid frequent

erasing of the memory, the data set in the quick setting mode will not be saved. Power is lost, and only the data set in the MENU will be saved and automatically called when the next power is turned on.

4.2.16 Loading method

```

▶ 20 . Load Set
  21 . Default Set
    
```

```

Load Set
Value = 1
    
```

- 1) In non menu mode, press MENU to enter menu mode
- 2) Press ▲、▼ to the main menu item 20. Load Set.
- 3) Press OK to enter the menu item
- 4) Press ▲、▼ to increase or decrease data, and press, to switch data bits and select the storage location to be loaded.
- 5) Press OK to confirm and the MENU will return to the main MENU automatically
- 6) Press the MENU key to exit the menu mode
- 7) At this point, the contents of the selected storage location are loaded and called to cover the current menu settings.
- 8) The loading storage location ranges from 1 to 10, and the default location is No.1.

4.2.17 Restore the default settings

```

▶ 21 . Default Set
  22 . Auto PWR OFF
    
```

Default Set
▶ NO

- 1) In non MENU mode, press MENU to enter MENU mode
- 2) Press ▲、▼ to the main MENU item 21. Default Set.
- 3) Press OK to enter the MENU item
- 4) Press ▲、▼ to select YES to restore the factory settings.
- 5) Press OK to confirm and the MENU will return to the main MENU automatically
- 6) Press the MENU key to exit the MENU mode



[Note] Use this function, all settings will be restored to the factory settings, including the settings stored by the user, which will be completely cleared!

During the process of restoring to the factory settings, the machine will not respond to the key operation for about 1 ~ 2 seconds.

4.2.18 Version information

▶ 23 . V e r s i o n

- 1) In non menu mode, press MENU to enter menu mode
- 2) Press ▲ and ▼ to the main MENU item 23. Version.

- 3) Press OK to enter the menu item
- 4) Check the firmware version number and identification number of this machine. This MENU item cannot be edited by users.
- 5) Press OK or ESC to return to the main menu.

- 6) Press the MENU key to exit the menu mode

Users can check the information of this machine through this MENU, and the firmware versions of the instruments shipped from different periods may not be the same;

5. Troubleshooting and diagnosis

5.1 Error List of PC

When the upper computer workstation detects a fault, an error prompt dialog box will pop up, and the user can judge the cause of the fault and take correct solutions according to the prompt information in the dialog box.

Table 5-1 Error code and fault comparison table

NO.	Item	Reference solution
1	Evaporation tube temperature sensor failure	Contact the after-sales engineer
2	Pressure sensor failure	Contact the after-sales engineer
3	Flow sensor failure	Contact the after-sales engineer
4	Nozzle temperature sensor failure	Check whether the nozzle leads are connected properly and contact the after-sales engineer. Failure: affects the nozzle heating function.
5	SYSTEMERROR	Restart the instrument after power failure and contact the after-sales engineer.
5	Evaporation tube heating failure	Contact the after-sales engineer
7	Back fan failure	Contact the after-sales engineer
8	Bottom fan failure	Contact the after-sales engineer Failure: The rapid cooling function fails.
9	ADC error	Contact the after-sales engineer
10	External error	Check external equipment
11	Serial interface error	Check the connection and contact the after-sales engineer Failure: affecting external communication function
12	USB interface error	Check the connection and contact the after-sales engineer Failure: affecting external communication function
13	Network failure	Check the connection and contact the after-sales engineer Failure: affecting external communication function
14	Power failure	Contact the after-sales engineer
15	PMT high voltage error	Contact the after-sales engineer
16	Communication error	Contact the after-sales engineer

5.2 Other troubleshooting and treatment

Table 5-2 Other troubleshooting table

NO.	Fault phenomenon	Possible causes	resolvent
1	Detector not working	The fuse is blown	Replace the fuse
		The power is not working	Power on again
2	There is no air pressure	The valve doesn't open	Confirm valve status
		Wrong connection of gas pipe	Check the pipeline connection
		Carrier gas flow too low	Confirm that the air supply pressure reaches the
3	No detection signal	Connection error	Check wiring
		Instrument failure	Re open
4	Baseline instability	Carrier gas is not clean	Replace the carrier gas
		Mobile phase pollution	Filter the mobile phase or replace the mobile phase
		Improper evaporation temperature setting	Adjust the evaporation temperature
		Detector unbalanced	Let the instrument be fully balanced for a period of time
5	Heteropeak	Carrier gas is not clean	Replace the carrier gas
		Improper setting of evaporation temperature	Adjust setting parameters
		Mobile phase pollution	Filter the mobile phase or replace the mobile phase
		Spray nozzle contamination	Cleaning atomizer nozzle
6	Evaporation temperature can not	Drift tube, detection room contamination	Contact the after-sales engineer
		Temperature sensor failure	Contact the after-sales engineer

6. Maintenance and repair

To ensure the normal operation of the detector, some components need to be maintained and repaired. Maintenance is primarily simple, mainly referring to those requiring replacement of internal components, which can be done from the front panel of the instrument without removal from the stack configuration.

When replacing internal parts, it is necessary to open the detector cover and remove the faulty parts from the system. The specific operation procedures shall be operated by professional maintenance engineers on site or by professionals according to the maintenance process. In case of any maintenance problem, please contact Elliott customer service personnel.



[Note]

Without guidance, please do not open the detector cover, in case of any damage to body or instrument.

6.1 Daily maintenance

For the sensitivity of the D3270L evaporative light scattering detector.

Preventive maintenance is recommended as follows.

- 1) Make sure the detector is in a clean laboratory environment.
- 2) After each use of the detector, please discharge the corrosive solvent and the solvent containing modifier from the instrument, otherwise the atomizer will be blocked or the performance of the instrument will be reduced.
- 3) If the detector is not used for a period of time, thoroughly flush all mobile phases containing acid and alkali to prevent impurities from depositing in the components or corroding the instrument; Pull out the exhaust pipe, screw off the right angle elbow, and screw on the dust cover of the detector to prevent the detector from falling ash.
- 4) Use only clean gas (no particles, no oil residue).
- 5) Strictly follow the specification of D3270L ELSD.



[Warning]

Do not flush the test cell with nitric acid! Never use acetone! Avoid contamination of the test cell!

6.2 Daily shutdown process

The D3270L detector should be cleaned each time before shutting down the HPLC system, as follows:

- 1) Continue to flush the particles that may remain in the detector with mobile phase or solvent;

- 2) Increasing temperature decomposes possible sediments;
- 3) Stop the mobile phase and keep the gas for at least 30 minutes to dry the internal pipeline to prevent particles from settling;
- 4) Turn off the gas supply and lower the evaporation temperature;
- 5) After the instrument is cooled, turn off the detector.



[Note]

The execution time of the above steps is only the recommended value. Please adjust it according to the type and concentration of solvent and sample in actual application.

6.3 Instrument cleaning and disinfection

6.3.1 External cleaning of instrument

- 1) Turn off the power;
- 2) Disconnect all external connections (including electrical connection line, air inlet pipe, exhaust pipe, liquid pipes and waste pipes);
- 3) Cooling detector;
- 4) Clean the detector surface with a soft cloth. If necessary, a small amount of alcohol can be used to wipe oil or foreign matter.

6.3.2 Internal disinfection of instrument

- 1) The evaporation temperature of D3270L detector is set to 100 °C;
- 2) Use a flow rate of 1 ml / min to deliver the appropriate solvent (methanol is generally used, do not use corrosive solvents) to the system through the HPLC system (or other infusion equipment). Keep the flow rate and temperature stable and flush for at least 1 hour.

- 3) Stop the mobile phase and keep the gas for at least 30 minutes to dry the internal pipeline to prevent particles from settling;
- 4) Turn off the gas supply and lower the evaporation temperature;
- 5) After the instrument is cooled, turn off the detector.

6.4 Atomizer nozzle cleaning

To remove the atomizing nozzle from the instrument, follow the following steps:

- 1) Shut down D3270L detector and the whole liquid phase system;
- 2) Disconnect the liquid inlet of atomizing nozzle and chromatographic column;
- 3) Hold the blue gas inlet pipe of the nozzle with one hand and push it in slightly. Press the black sealing ring at the gas inlet with the other hand, and then pull out the gas input pipeline;
- 4) Pull out the heating lead of the nozzle from the socket in the inner cavity of the atomizing chamber;
- 5) Screw down the red plastic threaded cover with the nozzle from the upper end of the glass atomizing tube together with the atomizing nozzle;
- 6) Use 8 mm fixed wrench (instrument accessory) to screw off the quick connection of gas inlet anticlockwise, so as to prevent the sealing ring from being damaged by cleaning solution. Pay attention to keep the sealing ring on the interface;

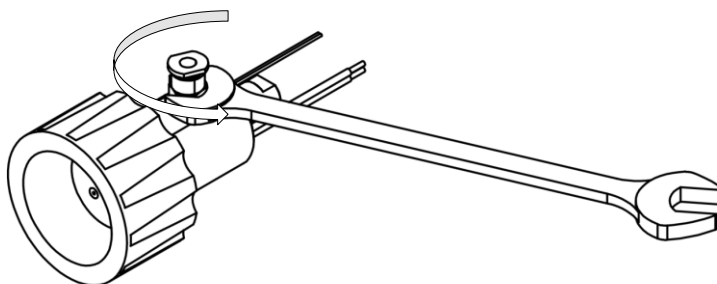



[Note]

Take out the red plastic threaded cover from the rear of the atomizing nozzle, and remove the sealing gasket at the same time, and keep it well.

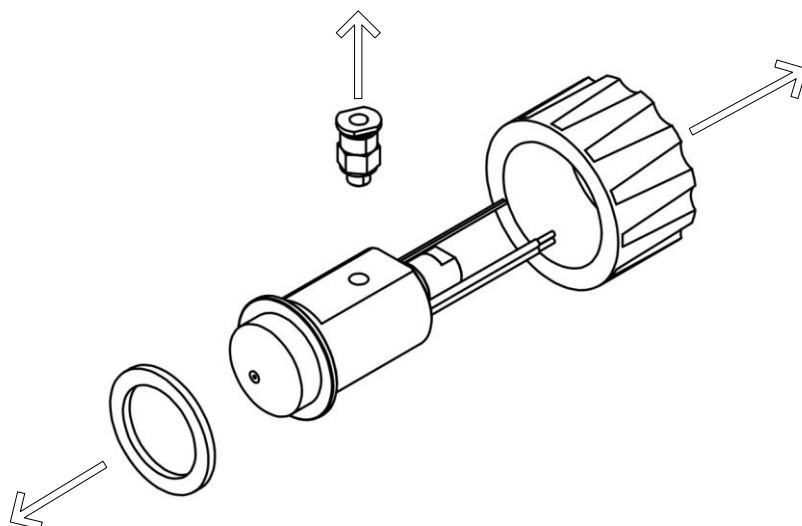

Cleaning nozzle

- 1) Add appropriate amount of water into the ultrasonic cleaning machine, and then pour the appropriate solvent with a height of about 2 cm into a 50 ml beaker. In most cases, ethanol can be used;
- 2) Put the sprayer vertically into the beaker containing 2 cm solvent. The bottom of the atomizer nozzle should be placed at the bottom of the beaker, and the inlet should be upward. Please be careful to prevent the part behind the nozzle and the heating cable from contacting with the solvent, and then put the beaker into the ultrasonic cleaning machine;
- 3) Clean the nozzle in the solvent for about 30 minutes, and then replace the solvent with water for 30 minutes again;
- 4) Dry the nozzle (or blow dry with clean air), especially heating cable socket.

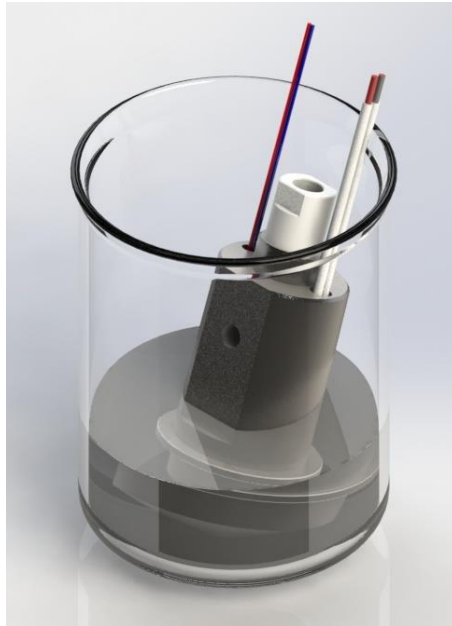

[Warning]

Do not disassemble the atomizing nozzle. Removing the atomizing can cause damage to the components.

7. Parts and materials list

7.1 Consumable parts

NO.	Item	Item No.
1	Stainless steel hand screw joint	14993017
2	Peek double cone edge ring	14990128
3	Finger Tight I	3215F-120X
4	Pre cut pipe-1 / 32 "series - 500mm	18990147
5	Peek tube OD1/16" × ID0.007"	13010014
6	Silica gel tube	13010119
7	External air pipe	13010126
8	Exhaust pipe	13010127
9	T-type tee	14992904
10	Cylinder interface	19000337
11	Insect net	19000338
12	Bellows right angle joint	14992988
13	Waste gas buffer tank	33120999
14	Power cord	17000119
15	Analog signal output line	17000092
16	External signal line (including 2 Port jumpers)	17000093
17	T5AL250V Fuse	15080032
18	Net cord	17000116
19	Atomizing nozzle assembly	33121000
20	Glass atomization tube assembly	33121001

Appendix

Safety information

- *General safety information*

At the different stages of the instrument operation, maintenance and repair, everyone should abide the following general safety rules. Breaking these rules may cause damage to instruments or staffs. Elite Analytical Instruments Co., Ltd. does not responsible for the impact caused by non-standard operation.

- *safety standard*

The instrument is class I safety equipment (i.e. providing protective grounding terminal), and is manufactured and tested according to national safety standards.

Safety signs

Symbols	Descriptions
	Please do not operate beyond the scope of caution, unless you have been fully understood and meet the required conditions.
[Warning]	Casualties may appear. Please do not operate beyond the scope of warning, unless you have been fully understood and meet the required conditions.
[Caution]	Data loss or equipment damage may appear. Please do not operate beyond the scope of caution, unless you have been fully understood and meet the required conditions.
【 Note 】	Unsatisfactory experimental data and instrument failure may appear. Please do not operate beyond the scope of note, unless you have been fully understood and meet the required conditions.

Common solvent information

Common volatile buffers and volatile mobile phase modifiers

Item	pKa	pKb	pH Range	BP	MP
acid					
Trifluoroacetic acid	0.3	13.70		72.4°C	
Formic acid	3.75	10.25		100.7°C	
Acetic acid	4.75	9.25		116.0°C	
Carbonic acid	6.37	7.63		-	
Alkali					
Ammonia	9.25	4.75		-33.35°C	
Methylamine	10.81	3.19		16.6°C	
Ethylamine	10.66	3.34		-6.3°C	
Triethylamine	11.01	2.99		89.3°C	
Buffer solution					
Ammonium formate			3.0-5.0		120°C
Pyridone formate			3.0-5.0		
Ammonium acetate			3.8-5.8		111°C
Pyridinium acetate			4.0-6.0		
Ammonium carbonate (for reverse phase)			8.0		
Ammonium carbonate			5.5-7.5 和 9.3-11.3		
Ion pairing agent					
Pentafluoropropionic acid	≈0.6			96-97°C	
Heptafluorobutyric acid	≈0.6			120°C	
Pentafluorovaleric acid	≈0.6			140°C	
Pentafluorooctanoic acid	≈0.6			189°C	
Trifluoroheptanoic acid	≈0.6			175°C	

ELITEHPLC

About Elite

Suzhou Elite Science & Technology Co., Ltd.
701#, Building 10, Liandong U Valey, No. 179 Zhujiawan Street,
Gusu District, Suzhou, Jiangsu, China.
Tel: +86-512-67997535
E-mail: info@eliteHPLC.com
Web: <http://www.elitehplc.com>
