

Operation Manual

For D1100 UV-visible Detector

V1.0.5

ELITEHPLC

Statement

The manual describes various contents of D1100 detector. It is intended to help users to understand, use and maintain the instrument of D1100; Elite Analytical Instruments Co., Ltd. does not assume the responsibility caused by the manual.

This manual is subject to change without notice.

This manual has been published, after careful review, it is believed to be accurate and complete. Elite Analytical Instruments Co., Ltd is not responsible of any error that may appear in the manual and the resulting incidental or renewal of harm.

In any case, Elite Analytical Instruments Co., Ltd. does not responsible for the impact caused by the use of this manual and equipment.

This manual Copyright owned by Elite Analytical Instrument Co., Ltd. Without the authorization of the company, any unit and individual shall not copy, reprint or reproduction in this manual in whole or in part.

Precautions

Thank you for your continuous patronage. Observe the following precautions in order to make safe and stable use of the instrument.

Precautions are divided into three groups in this operation manual depending on the degrees of danger. The three groups are



[Warning] Failure to properly follow the instructions and precautions indicated by this sign can result in serious injury or damage to health and property. The property damage includes the environment around and the instruments.



[Caution] Failure to properly follow the instructions and precautions indicated by this sign can result in slight injury or damage to health and property. Slight injury means no hospitalization is needed to the wounded. Slight property damage means the instruments can be recovery through simple maintenance.



[Note] The sign is used wherever information is given to ensure optimal performance of the detector.

1. Precaution for usage



[Warning] D1100 pump should only used as a part of liquid chromatography. Do not use it any other purpose. Except for special instructions, the instrument does not have explosion-proof function.

2. Ambient Conditions



[Warning] When we use organic solvent. It is recommended that interior must be well ventilated, the firework should be prohibited. Also, a sink or equipment for washing eyes should be installed nearby in case of the organic solvent coming into contact with the eyes or skin.



[Note] In order to ensure good efficiency, keep the instrument away from caustic gas and dusty environment. The width of worktable should be more than 600mm. Ambient is between 10°C to 30°C with a small fluctuation, and RH is between 45% to 85%. Avoid it from cold or hot source as well as direct sunshine. The system should not close to strong magnetic field.

3. Precaution for installation



[Warning] The instrument should be installed following the instructions strictly by professionals, make sure that the voltage of the power socket is the same as the power supply voltage indicated on the instrument. Using the wrong power voltage could result in danger and fire.

The accessory power cable should be used to connect the instrument to the power socket. Other cable should not be used.

The equipment should be connected with protective earth to prevent static and leakage.



[Caution] The instrument is so heavy, you should move it carefully and watch your hands in the same time.



[Note] The instrument should be connected following the instructions strictly. Wrong connection could cause communication error.

4. Precaution for use



[Warning] Do not use the instrument in places where heat resource, fire seat, magnetic resource, strong vibration exist or may exist. It is prohibiting to play flammable nearby.

The bottle for storing the mobile phase should have pore in cap to prevent danger caused by negative pressure in the bottle.

A gap between waste tube and the cork of waste bottle is necessary to prevent the waste bottle bursting when it is overfilled. The gap should be smaller to ensure less evaporate of hazardous solvents. Even though, the waste need to be clean up promptly.



[Caution] When using organic solvents, please wear safety goggles, special lab coats, gloves mask etc. .If your body contact with toxic solvent accidentally, wash it immediately, and then go to hospital for specialized treatment.



[Note] When preparing mobile phase, please use HPLC-grade or equivalent at this level solvents. Solvents must be prefiltered by the manufacturer with a 0.45- μm (or smaller).Degas all mobile phase before using it. Degassing can help to ensure a stable baseline and consistent analytical results.

Before first use, rinse the entire piping system according to the requirements of the manual, direct use is likely to block pipeline.

Before sample test, ensure that the pipeline in the system is filled with mobile phase without any bubbles, otherwise it will affect the reliability of test results.

If an eluent is replaced with another eluent which is insoluble, such as positive mobile phase (hexane) and reverse phase (methanol), be sure to operate according to the specified method in the manual, otherwise it will cause serious pipeline jam, and even system paralysis.

Do not use the following solvent: concentrated sulfuric acid, nitric acid, dichloroacetic acid, methylene chloride, chloroform, chloroform, dimethyl sulfoxide, acetone, tetrahydrofuran, etc. Such solvents always reduce the strength of the PEEK material, make it become fragile and broken, but short-term use of aqueous solution of acetone (lower than 0.5%) in gradient performance, the impact is acceptable.

When using PEEK pipes, the pressure of system should be lower than the tolerance pressure of PEEK material, otherwise it may burst.

The bending radius of PEEK pipe should be more than 10mm, make the PEEK pipe natural relaxation during installation.

The PEEK pipe should be intercepted with professional tube cutter in order to make the pipe smoother. Pay attention to that there is no cutting debris left in the pipe.

5. Repair, maintenance and parts replacement



[Warning] Before repair, maintenance and parts replacement, please turn off the power in case of leakage and electric shock.

There is no need to open the host cover while daily maintenance and repair. If the repair needs to open the host cover, please entrust agents or communicate with us.

Use a dry cloth to wipe the instrument. Do not use water or alcohol. The use of these liquids may erase characters or color on the panel.

Do not replace components (e.g., fuses, deuterium lamp, etc.) from other companies or other types, all accessories are required to be specified to prevent danger.

6. Precaution for static electricity



[Warning] As this pump may use a lot of flammable, explosive organic reagents which can contaminate laboratory air. When the reagent concentration is too high, any spark or flame could cause fire or explosion accidents. Do not use the pump near any fire resource, hot resource, and static electricity resource. To reduce static electricity, please take the following measures:

- 1) Make the instrument grounded. It is very important, please pay attention to it.
- 2) Maintain proper indoor humidity (humidity is greater than 65% can prevent static electricity effectively). Keep the environment clean.
- 3) Metal waste bottles (external conductive) should be grounded (no ground insulation). When using other materials container, you can insert one end of the wire into liquid in the bottle and make the other end earthing.
- 4) Replace thicker pipe when the mobile phase's flow is large.
- 5) Wipe the instrument regularly.
- 6) Staff wear anti-static clothing, anti-static bag is needed on the floor.
- 7) People and objects with static electricity is prohibited to touch the instruments.

7. Warning label instructions

To ensure the safety of staff, we attach warning labels on the equipment where is danger. If the label is missing, please request new ones from the company, and attach to the correct position.

Contents

1. CHAPTER ONE: INTRODUCTION	1
1.1 Overview	1
1.2 Features and Functions	2
1.3 Performance Specification	3
1.4 Physical Specifications	3
2. CHAPTER TWO: INSTALLATION AND TRANSPORT	4
2.1 Unpacking inspection and standard accessories	4
2.1.1 Demolition of the packing	4
2.1.2 Deliver checklist.....	4
2.2 Installation Requirements	5
2.2.1 Site Requirements	5
2.2.2 Power and power line.....	5
2.2.3 Computer requirements.....	6
2.2.4 Communication connection	7
2.3 Tube Connection	7
2.3.1 Tube material	8
2.3.2 Cleaning the connect tube.....	8
2.3.3 1100 System connection instance	8
2.4 D1100 Front	9
2.5 D1100 Rear	10
2.6 System Configuration	11
2.7 Transportation	11
3. CHAPTER THREE: WORKING PRINCIPLE	12
3.1 Basic Theory	12

3.2 Principle and composition	13
3.3 control circuit.....	13
3.4 Circuit section	14
4. CHAPTER FOUR: BASIC OPERATION	15
4.1 Power On.....	15
4.2 Menu 1: Basic Operation	17
4.3 Normal Operation	17
4.3.1 Scan measure	17
4.3.2 Setting scan wavelength.....	18
4.3.3 Return to other interface	18
4.4 Time program	19
4.4.1 Setting the parameters of time program	19
4.4.2 Running time program.....	20
4.4.3 Stopping time program.....	21
4.4.4 Stopping error of time program	21
4.5 Detector working parameters	21
4.5.1 The switch state of deuterium lamp.....	22
4.5.2 The running time of deuterium lamp	23
4.5.3 Number of deuterium lamp open	23
4.5.4 The energy of deuterium lamp.....	23
5. CHAPTER FIVE: MAINTENANCE AND REPAIR	24
5.1 Cleaning the flow cell	24
5.2 Deuterium lamp replacement	25
5.3 Common failure diagnosis and elimination.....	26
APPENDIX.....	I
Consumption parts	I

Safety information	II
General safety information	II
Standard of security	II
Absorptive character of some typical functional groups	III
Features of some organic solvents	IV
Intermiscibility of commonly used solvents	VII

1. Chapter One: Introduction

D1100 UV-visible detector is based on years of experience in the research and production of detector. It is a high performance detector for HPLC system.

The light source of D1100 is deuterium lamp, mainly used in UV region. The detector has three work modes: single wavelength, wavelength-time program and spectrum scanning.

1100 Series products include D1100 UV-visible detector, P1100 constant flow pump, ST1100 solvent tray, W1100 workstations, GM1100 gradient mixer, VB1100 valve stents etc. For more information, please contact Elite Analytical Instruments Co., Ltd.

1.1 Overview

D1100 UV-visible detector (hereinafter called D1100 for short) includes optical unit, data acquisition, control circuit and data processing software, and other parts. The thermal light path structure was optimized, which make noise and drift more competitive than other budget instrument. It uses high precision stepper motor to drive grating Angle, which make the accuracy and precision of detection wavelength meet the demand of users. 24 $\Delta - \Sigma$ A/D conversion technology and double CPU structure based on MSP430 single chip microcomputer is adopted, which promote high precision of data acquisition, data processing and management system come true. Detector signal can be output by the RS - 232 or two USB interface to the computer, instruments communicate by RS-485 line, all the above structure make the whole HPLC system simple and reasonable.

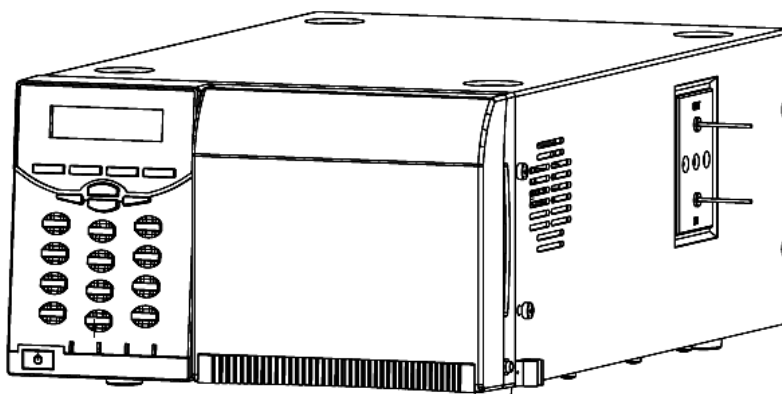

Figure 1-1: D1100 UV-visible detector

1.2 Features and Functions

Excellent noise and drift

By optimizing the dissipation structure of the optical path, the detector can maintain the optimal temperature, which helps to keep it an optical performance through longer time as well as effectively reducing the noise and drift.

Automatic spectrum scanning

When the mobile phase is stationary, scan the samples to get it's ultraviolet-visible absorption spectra, which can help users to determine the best measuring wavelength.

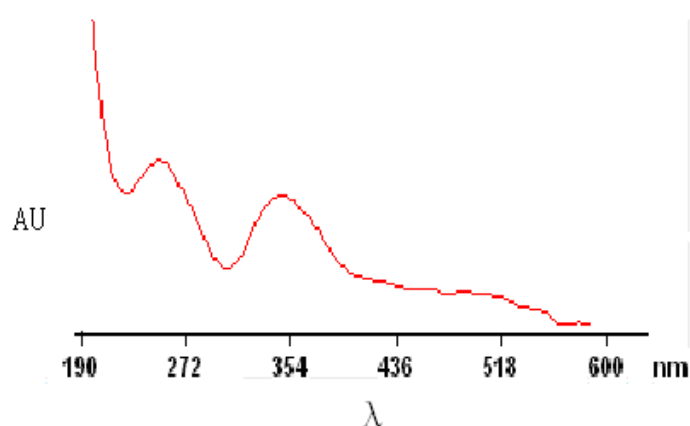

Figure 1-2: D1100 Ultraviolet absorption spectrum standard solution

Wavelength-time program

When a variety of compounds analysis at the same time, using wavelength-time program can ensure samples detected under the best wavelength, which improves the detection sensitivity effectively.

Convenient solvent flow

Liquid flow is added in the side of instrument. The improvement make it more convenient to discharge waste solvent.

1.3 Performance Specification

Table 1-3: Performance Specification of D1100 detector

Item	Specification
Wavelength range	190nm-700nm
Light resource	Deuterium lamp
Display	2×16 LCD
Spectral bandwidth	8nm
Wavelength accuracy	±1nm
Wavelength repeatability	≤1nm
Set fan of wavelength-time program	0.1min-999.9min
Response time	0.1s-5.0s
Noise	≤±1.0×10 ⁻⁵ AU(Empty flow cell、254nm、Constant ambient temperature)
Drift	≤2.0×10 ⁻⁴ AU/h(Empty flow cell、254nm、Constant ambient temperature)
Linearity range	≥1.8AU(5%)(254nm)
Optical path of flow cell	10mm
withstand voltage of flow cell	≤8MPa
Communication mode	RS232 or USB

1.4 Physical Specifications

Table 1-4: Physical Specification for D1100 detector

Dimension/Weight	420mm×260mm×160mm/14kg
Power Supply	AC 220V,50Hz
Power	100W

2. Chapter Two: Installation and transport

2.1 Unpacking inspection and standard accessories

D1100 UV-visible detector is packaged with corrugated boxes and foam lined structure. When you receive the instrument, check the packaging first, if the packaging is damaged, please contact with Elite Analytical Instruments CO., Ltd. or local dealer.



[Warning] If there is any damage to the instruments when you receive it, please don't try to install it. You can ask Elite Analytical Instruments CO., Ltd to inspect and assess it.

2.1.1 Demolition of the packing

Put the detector on level ground with the face of the packing box up. Cut the tape on the top, take out the pump and accessories package, place it on the table. then, remove foam, open the instrument protective film.



[Warning] The detector is heavy, it is suggested that installation operation requires at least two people to prevent instrument slide.

2.1.2 Deliver checklist

Before installing, please check the deliver list carefully, if one or several of them omissions, please communicate with Elite Analytical Instruments CO., Ltd. Or local distributors as soon as possible.

Table 2-1: Deliver list of P1100 pump

NO.	Item	Quantity
1	D1100 detector	1 pc.
2	Certificate	1 pc.
3	Service Card	1 pc.
4	Start Package	1 pc.



[Note] If there is discrepancies between the packing list in the box and in the specification, please refer to the packing list in the box, It is subject to change without prior notice.

2.2 Installation Requirements

2.2.1 Site Requirements

Environment

D1100 detector need to work under ambient conditions in Table 2-2 below:

Table 2-2: Environment requirements

Item	Specification	Requirements
1	Work environment	Room should be free of dust, inflammable and explosive materials, good ventilation is also important
2	electromagnetic field	No electromagnetic noise nearby
3	Operating temperature	4~40°C (39~104°F)
4	Humidity	20%~80% , non-condensing
5	Temperature fluctuation	< ± 2°C /hr



[Caution] Do not use the detector under conditions of temperature fluctuations. If the ambient temperature is too low, make the room temperature increase slowly to avoid condensation inside caused by rapid heating.

Bench space

The D1100 detector's dimensions allow placing it on almost any laboratory bench. If you want to display the complete 1100 system on the bench, make sure that the table can bear the weight of all components(no more than 50kg). It needs additional space of 50mm on the left,150mm on the right,150mm on the back to facilitate the circulation of air, electrical connections.



[Warning] The instruments should be placed on a horizontal position, otherwise there is a danger of falling!

2.2.2 Power and power line

To ensure the instrument can be normal and safe, please use a dedicated power line within the specified voltage range.

Grounding, ac power to 220 v ± 10%, 50 Hz;

Please choose T1.0 A (250 v) fuse.



[Warning] The accessory power cable should be used to connect the pump with the power socket. Other cable should not be used in case of danger or damage to the instrument.

If the instrument is connected to a grid above the scope of application, it may cause electrical shock or damage to the equipment and staff.

Please unplug the power cord before replacing the fuse to avoid electric shock. The external fuse is installed in the back of instrument.

2.2.3 Computer requirements

Hardware requirements

- The lowest hardware requirement: Inter Core 2 CUP, 2G internal storage, more than 1G hard-dist space; (Refer to the use of W1100 workstation)
- The lowest resolution of displayer: 1024×800, 64K(16 bit image);
- Others: USB or RS232 interface for communication, CD-ROM driver for software installation。

Operation system requirements

- Windows XP Professional(SP3)、Windows 7 or higher version(Refer to the use of W1100 workstation).

Workstation requirements

- Use W1100 workstation to control the instruments.

2.2.4 Communication connection

Communication, management and control functions between 1100 components is completed by detector, the communication line is connected as follows:

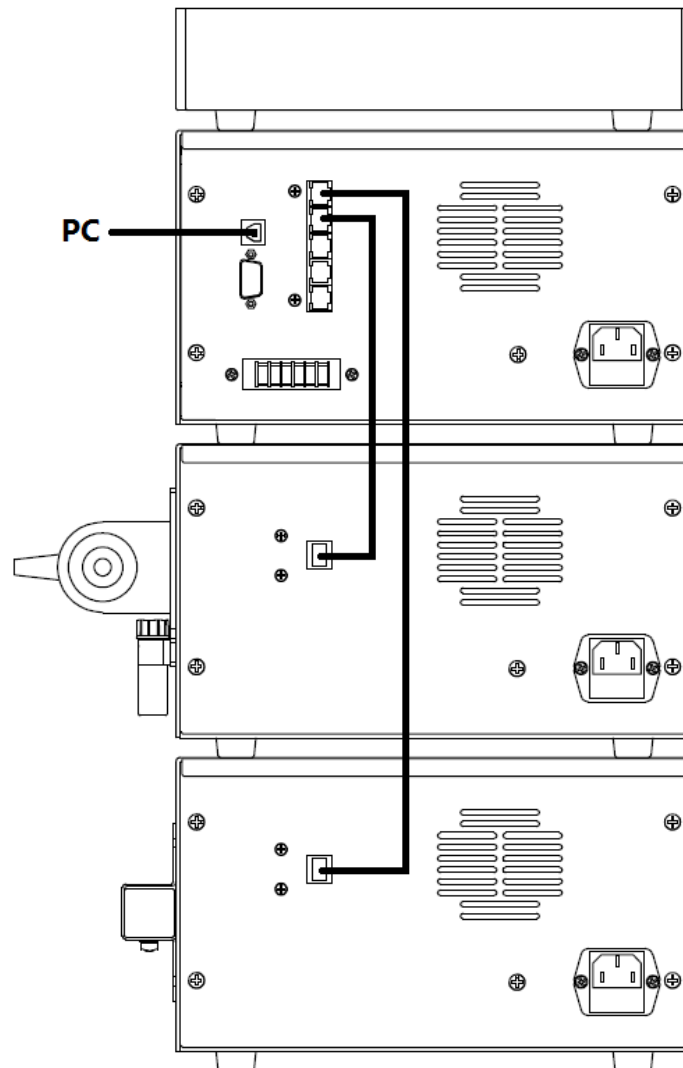

Figure 2-1: 1100 HPLC communication

2.3 Tube Connection

In addition to the column system, piping, fittings and injector, detector volume are likely to cause bands broadening. Inappropriate tube material also lead to band broadening, even to degeneration of the sample. Please connect the tubes with instruments correctly to improve efficiency. The tips are as follows:

2.3.1 Tube material

Different material of tube is required according to the working pressure, the kind of mobile phase and the nature of sample. The commonly used tube materials are as follows: stainless steel, polyetheretherketone (PEEK), polytetrafluoroethylene, polyethylene or polypropylene. The most commonly used material is stainless steel. The outer diameter of LC connection tube is 1.59mm(1/16"), the inner diameter of LC tube are 0.175mm (0.007"), 0.25mm (0.01"), 0.5mm (0.02"), 0.75 (0.03") mm and 1.0mm (0.04") etc., user can choose from them. Stainless steel tube is generally used for high-pressure part.

Polymer tube can be used in low-pressure part of LC System, such as from reservoir bottle to pump, detector outlet, injector discharge port, etc.. The polymer tube is the most common connection tube in LC system.

PEEK tube can withstand about 30MPa pressure, it is more inert than stainless steel pipe which means it is a good choice for separation, analysis and preparation of biological samples. In bio-separation system, PEEK is alternative materials for stainless steel.

2.3.2 Cleaning the connect tube

Please wash new pipeline with solvent before use. Cleaning order: chloroform - methanol (ethanol) - Water - 1mol/L nitric acid - water - methanol - dry with nitrogen stream. Also, silicone tube should be rinsed with methanol before use.

2.3.3 1100 System connection instance

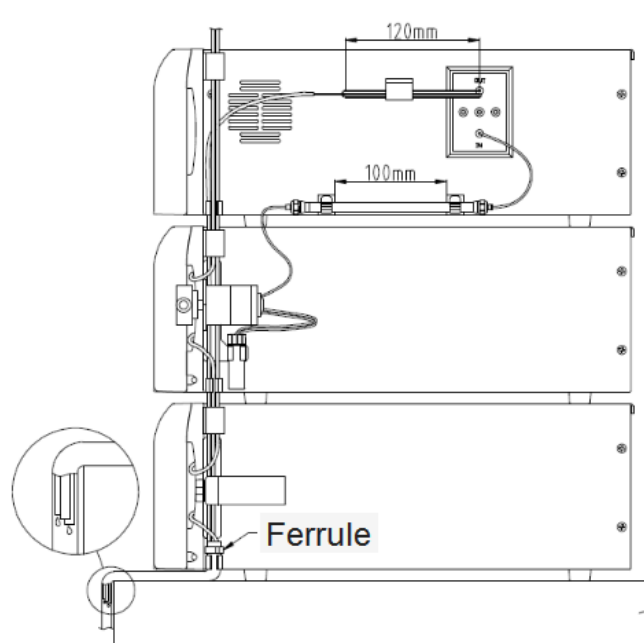

Figure 2-2: 1100 System connection diagram

2.4 D1100 Front

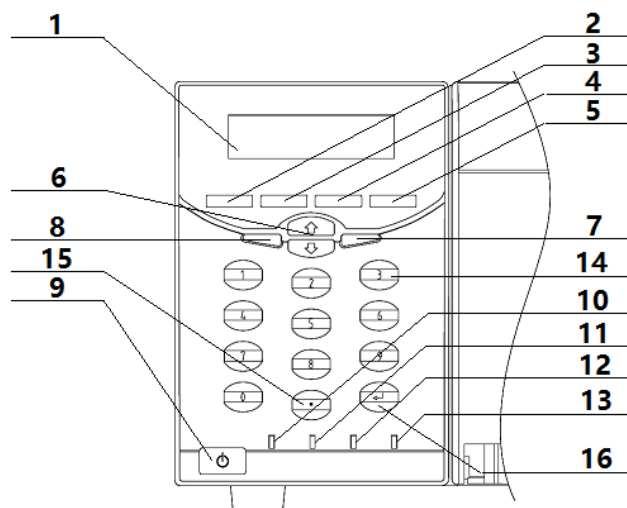

Figure 2-4: Front of D1100

Table 2-3: Keypad Function

No.	Key	Function
1	VFD – display	VFD displays operational status, menu and sub-menus, and parameters' values and units.
2	Zero	Press the button can make the absorption signal (ABS) displayed automatic back to zero, at the same time detector output the zero signal to the recorder, integrator and workstation.
3	Mark	Every button, the detector will produce the pulse signal and mark on the recorder.
4	CLEAR	To delete wrong data input or to disarm an alarm.
5	MENU	To access to function menu. Press the MENU key once, to access to the respective MENU1. Press again, to MENU2.
6	↑↓	Press ↑ and ↓ key to move between different menu and sub-menu.
7	Prog.	To start/stop wavelength-time program.
8	Energy	To display the current energy and reference energy.
9		Power switch
10	POWER	Power is on when the indicator is illuminated.
11	D2	When the D2 indicator is illuminated, the deuterium lamp is working normally.
12	W-up	When the W-up indicator is illuminated, the deuterium lamp is preheating.
13	Alarm	When the alarm indicator is illuminated, the energy of detector is lower than setting value or circuit problems occur.
14	0 – 9	Numerical keys
15	.	Decimal point
16	ENTER	To confirm values and selections. Upon pressing ENTER key, the cursor will automatically move to the next parameter.

2.5 D1100 Rear

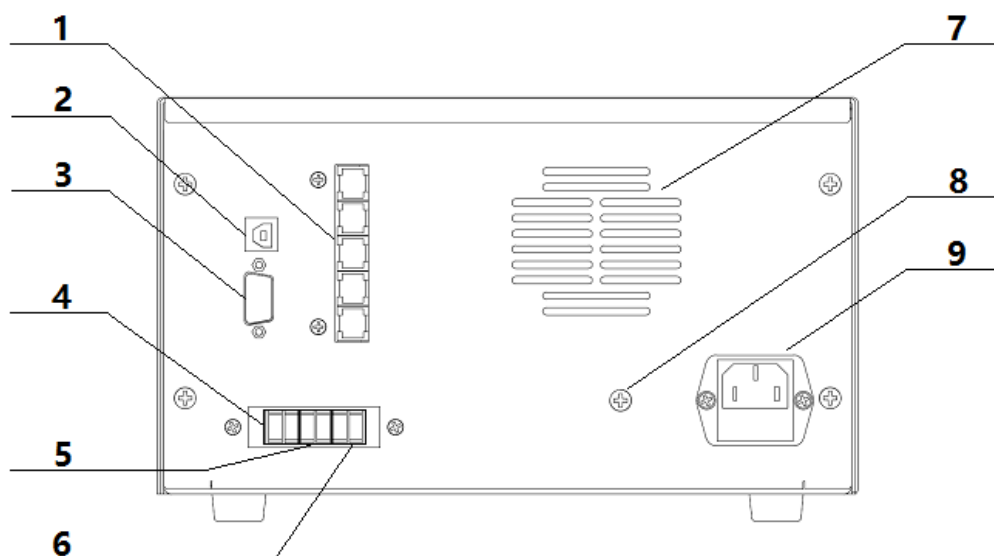

Figure 2-6: D1100 detector rear panel

Table 2-4: Rear panel

No.	Component	Function
1	RS485 interface	The communication interface between the instrument.
2	USB interface	The communication interface between the instrument and workstation.
3	RS232 interface	The communication interface between the instrument and workstation.
4	DA	The voltage value of full output range is 2V, the output unit is 1 AU/V. (option)
5	ZERO	Baseline back to zero and start to collect data.
6	WL	To start wavelength-time program and begin to collect data.
7	Cooling fan vent	Cool the instrument.
8	Ground terminal	To ground the main body of the pump.
9	Power connector	The power cable is connected into grounded power outlet.

2.6 System Configuration

In normal instance, the instrument customers received have been tested and came with verification, the performance met our requirements in factory, users have no need to test and verify. If you have any doubt about the performance of the instrument, verify it refer to the following steps:

- 1) Take a chromatographic column, the positive phase system selected SiO₂ column, inverse system using C18 column.
- 2) Prepare mobile phase and samples according to evaluation report provided by the column manufacturer.
- 3) Empty air bubbles in the system, when the system is stable, detect it according to the testing requirement.
- 4) If the result and column efficiency is conform to the information provide by column manufacturer within the error range, that means the HPLC is qualified.

2.7 Transportation

The detector is a precision instrument, please gently while long-distance transportation, severe vibration, drops are likely to cause damage to the internal parts of the instrument. The random original packaging can effectively protect the instrument. When the instrument is required to move or returned for service, please follow these steps for packaging.

Turn off the power.

Unplug the power cord and communication lines.

Removing the connecting pipe and other elements between components.

Remove the detector from chromatography system, put it into special sealed bag on a large platform.

Put the detector into the original packaging foam, fix it.

Placed the fixed detector and other accessories into original packaging carefully.

Tape the box sealed to prevent liquid from entering. Cover the packaging box with plastic wrap is recommended.

Transport packaged instrument.



[Warning] Before packing, please check the box, if the original packaging has been damaged, do not use it, you should consult your local dealer or Elite Analytical Instruments Co., Ltd. customer service staff to solve!

3. Chapter Three: Working Principle

3.1 Basic Theory

Material molecular can absorb ultraviolet-visible light, which conforms to Lambert Beer law.

I_0 is Intensity of the Incident Light, I is the transmitted light intensity(refer to figure 3-1), the Lambert Beer law can be written as:

$$I = I_0 e^{-\epsilon lc}$$

l ——Optical path length of flow cell,

c ——The molar concentration of the sample,

ϵ ——The molar absorption coefficient of the sample.

Definition:

$$T = I / I_0$$

T is the transmittance for the sample under a particular wavelength.

So:

$$A = \epsilon lc = \log\left(\frac{I_0}{I}\right)$$

A is defined as the light absorption value.

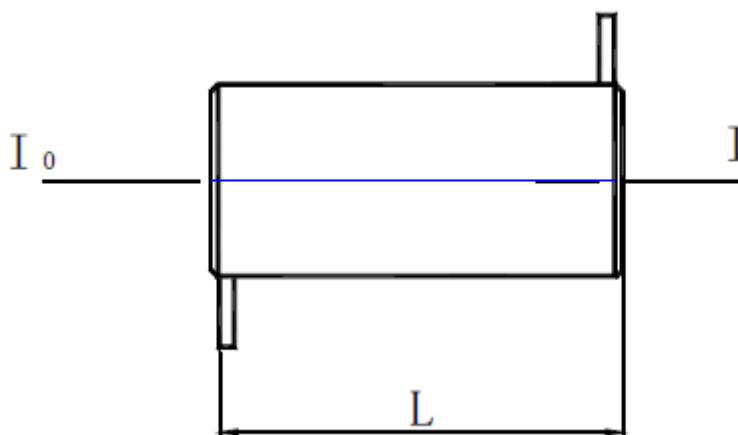

Figure 3-1: The absorption of samples in the flow cell

Thus, light absorption value A is linear to samples concentration c . The sample concentration can be obtained by measurement of light absorption value. Molar absorption coefficient is relevant to light wavelength, sample on molecular structure and solvent, it shows absorption ability of sample molecules under a particular wavelength. Annex I listed some typical groups of characteristic absorption wavelength and the corresponding ϵ value.

3.2 Principle and composition

Figure 3-2 is the general structure diagram of detector, the light is split by monochromator and goes through the flow cell. Different samples absorb light of different wavelengths, which make the intensity of transmitting light change. Photoelectric cell receives these light and then transmitted to the control circuit for signal processing.

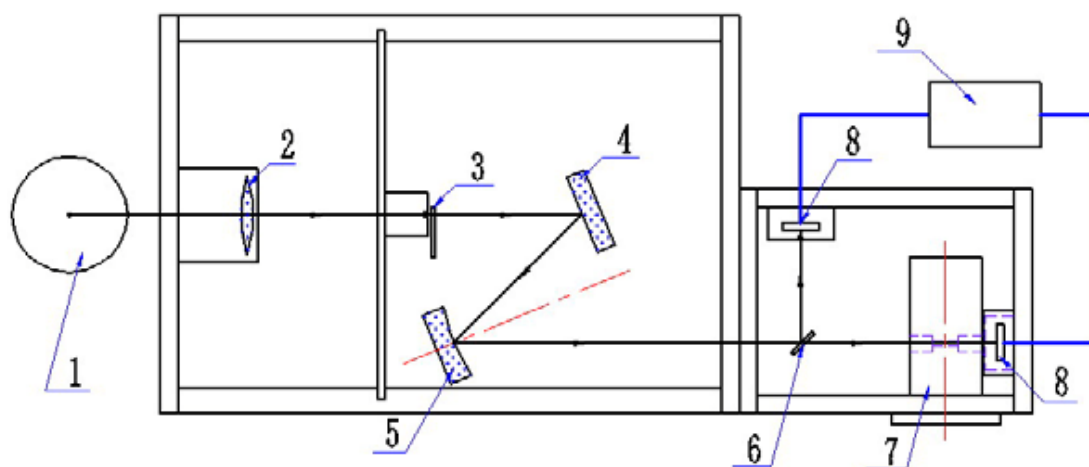

Figure 3-2: The overall block diagram of D1100 optical system

- 1.Light source, 2.Lens, 3.Optical filter, 4.Reflector 5.Holographic flat-field concave gratings, 6.Beam splitter, 7.Flow cell, 8.Amplifying circuit, 9.Control circuit

3.3 control circuit

D1100 UV-vis detector optical system include light source (deuterium lamp), a focusing lens, monochromator, splitting mirror, flow cell, etc (FIG. 3-2 light path).

Light from a light source 1 go through lens 2 into the monochromator, then it is split to measure light and reference beam. The measure light is got by light receiving element from flow cell, and deal by amplifying circuit 8, then it is transferred to control circuit 9. The reference beam exposure to the amplifying circuit 8 directly, and transfered to control circuit 9 for signal processing.

3.4 Circuit section

Control system of D1100 detector is double CPU structure, based on MSP430 16 bit single chip microcomputer, the system consists of liquid crystal display, keyboard, 24 bits of high precision AD conversion, 20 DA conversion (optional), motor drive circuit (Figure 3-3). The photocurrent signal of photoelectric diode come through signal processing and AD converter, then, it is converted into digital signals. After that, the digital signal is handled by microprocessor including data operation, processing and control. The application of the high integration components and devices make the reliability and stability of the instrument improved.

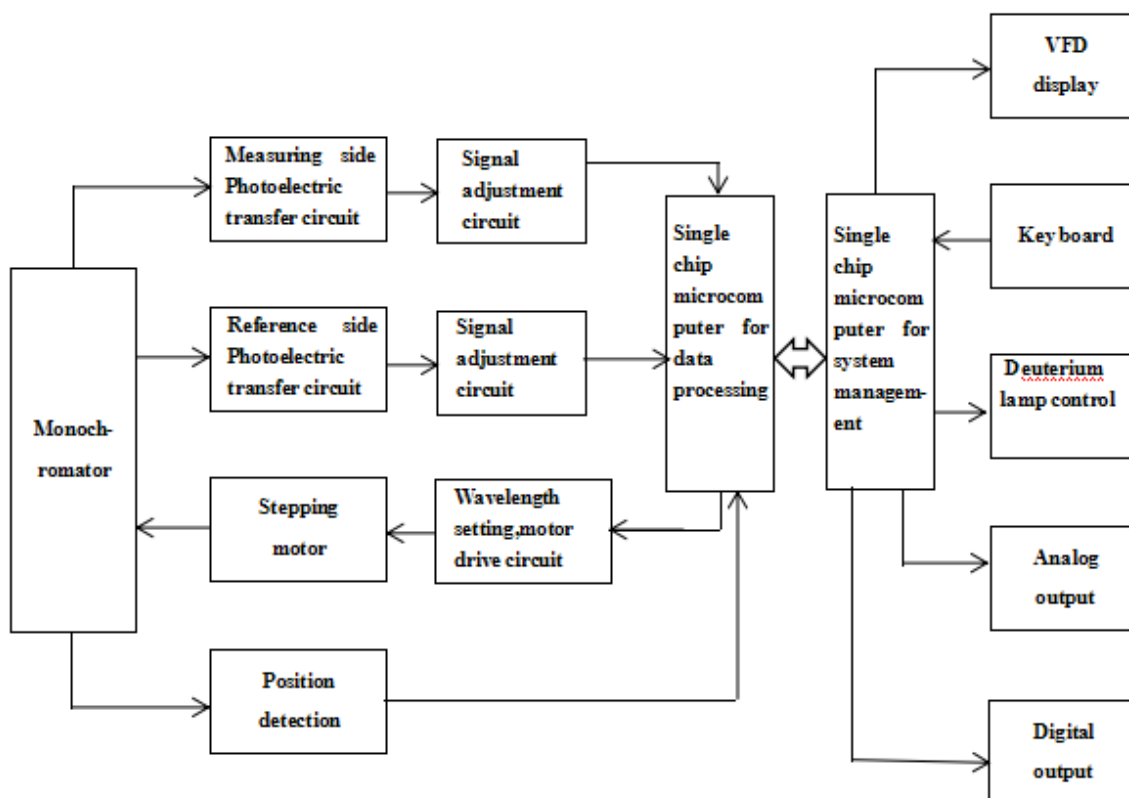

Figure 3-3: Circuit system frame

4. Chapter Four: Basic Operation

Before operating D1100 detector, please connect the system properly and confirm the power supply, the following is operation orders:

4.1 Power On

Please plug the power cord into the power outlet.



[Caution] The power switch is turned off at this time.

Turn on the power switch(lower left corner of the front panel).

Power indicator light, LCD screen is bright, D1100 detector begins to self-test. The LCD display sequence is as follows:

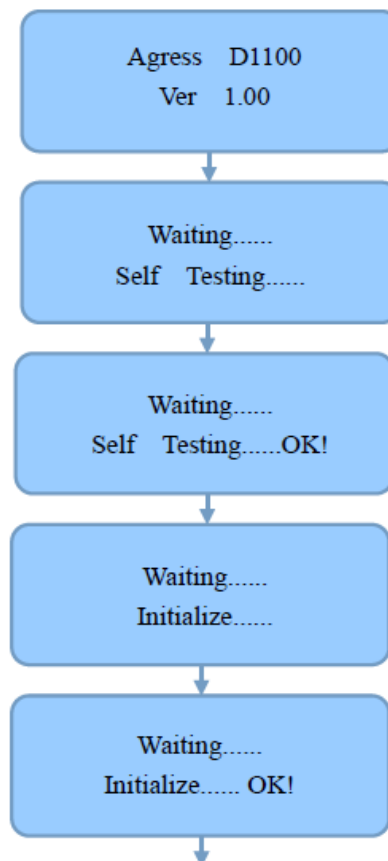

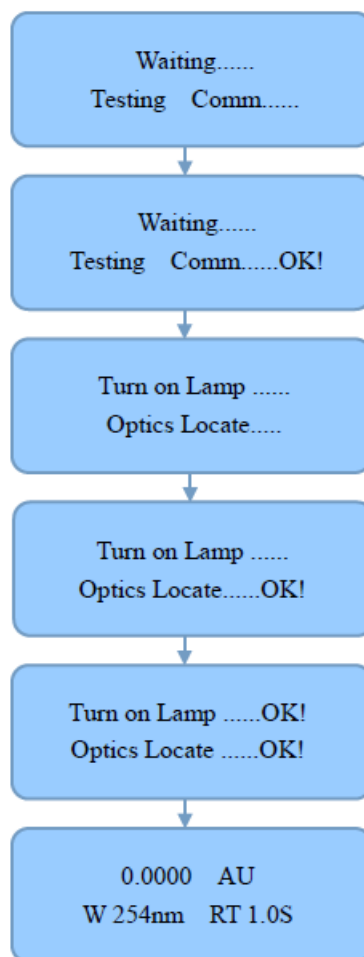

At the same time a deuterium lamp on the front panel indicator is lit on.



[Caution] If this is the first time you use the D1100, the main interface parameters are default parameters, All parameters of the detector is maintain the previous shutdown parameters.

If the instrument is shutdown, a Interval of more than 3 minutes is need before it is turned on again.

4.2 Menu 1: Basic Operation

Setting the detector wavelength and response time

In the main interface, you can modify the detect wavelength and response time, if you want to modify a parameter, first press the "←" Enter key, and then press "↑, ↓" key to move the cursor to the parameter to be modified, after typing the new parameter value press "←" button to confirm. If there is any error in the process of setting, "ERR" will occur.

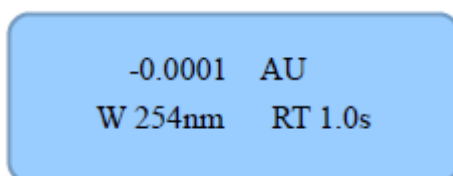

Response time

Detector response time is also called time constant, defined as 63.2% of the time from the sample coming into the flow cell to the real signal output. Response time is the measure of time a response signal comes out from the sample entering into the detector, it reflects the detector tracking speed about the changes of component concentration. If detector and recorder's time constant is too big, peak shape distortion, column efficiency decline may occur, also reliability and accuracy of analysis will be affected by it, for components whose preserving time is short, the time constant of the detectors should be as small as possible.



[Caution] RT range of D1100 detector:0.1-5.0s

4.3 Normal Operation

4.3.1 Scan measure

From the main interface, press MENU button to access to "MENU-1 Scan Measure".

You can use ↑ and ↓ to access parameters in MENU1, include scan wavelength setting and scan speed setting.

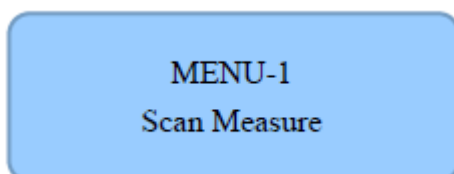

4.3.2 Setting scan wavelength

You can use ↑ and ↓ to enter scan speed setting interface, press numeric keys to set beginning scan wavelength and the ending wavelength, then press "←" to alter the parameters.

The starting wavelength

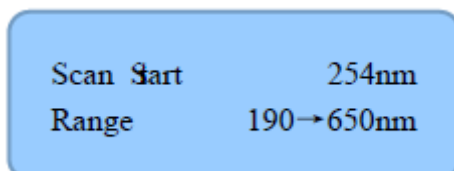

The ending wavelength

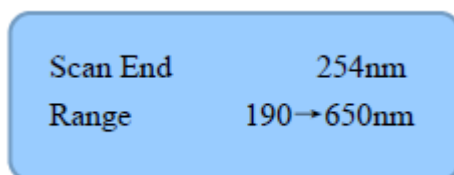

If setting parameters beyond the scope, the following interface will display for several seconds and then back to setting interface, you can set proper value again and press "←" button to confirm.

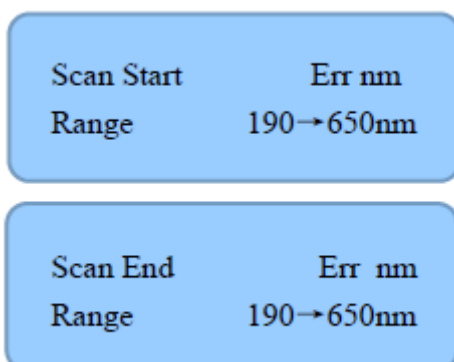

4.3.3 Return to other interface

When you press the "MENU" button continuously, the liquid crystal display will circulate between MENU1, MENU2, MENU3 and main interface. According to your requirements, you can stop at any state setting parameters or conducting an analysis at main interface.

4.4 Time program

Time program menu is used to set a specific time of wavelength change.

4.4.1 Setting the parameters of time program

You can press the "Menu" button continuously to enter into "MENU 2". When "MENU 2 Time Prog." is displayed, press "↓" button, then you will come into edit interface for time program. Parameters can be edit include: starting time and starting wavelength, editable starting time and wavelength is nine. The procedure is as follows:

1) Press "MENU" button twice:

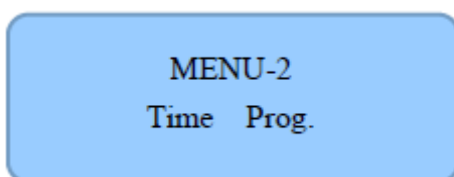

2) Press "↑" and "↓" button, 9 sub menu will be displayed in turn, you can set the parameters in corresponding interface

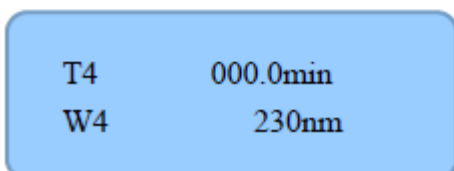
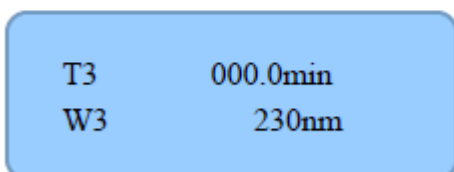
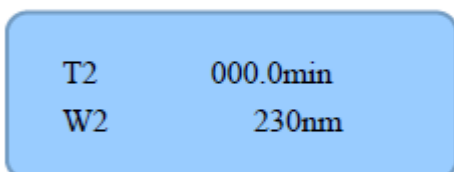
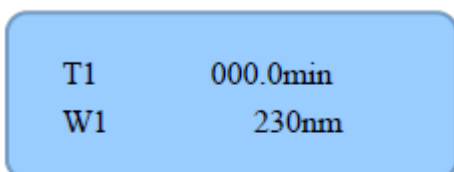
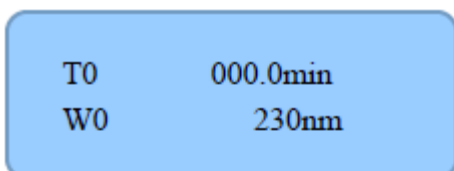

T5	000.0min
W5	230nm
T6	000.0min
W6	230nm
T7	000.0min
W7	230nm
T8	000.0min
W8	230nm

A set of wavelengths (190-700 nm) and time (0.1 to 999.9 min) value can be input into each sub menu. After finishing inputting, press " \leftarrow " to alter the parameters, then press " \uparrow " and " \downarrow " button to edit values of next set. If the inputting exceed the range of detector, the following information displayed, you can reset the values, and press enter button to confirm.

If the setting don't meet: $T_0 < T_1 < T_2 < T_3 < T_4 < T_5 < T_6 < T_7 < T_8$, it will shows error in the screen, resetting is needed. Wrong setting will lead to abnormally switch of main interface and sub menu, if the problem is discovered, Please check and correct your setting.



[Caution] If the period of time-wavelength is less than 9, the behind time and wavelength value should be the same as the last one.

4.4.2 Running time program

Pressing "Prog." button, the following information shows on the screen, the detector start running according time program.

W.L. Program
Has Started!

4.4.3 Stopping time program

After finishing the time program, the detector will come back to main interface. In the process of time program running, you can also press "Prog." button to stop it at any time, the detector will show the following information for several seconds before coming back to the main interface.

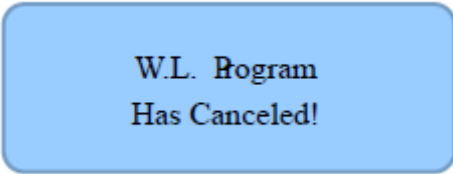

W.L. Program
Has Canceled!

4.4.4 Stopping error of time program

The following information occurs when there is something wrong with time program.

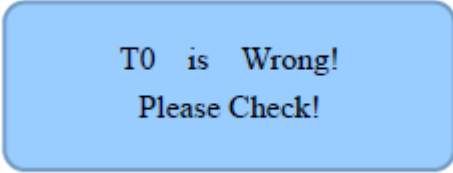

T0 is Wrong!
Please Check!

4.5 Detector working parameters



[Caution] There is only deuterium lamp in D1100 detector, so the following instructions for tungsten lamp is invalid.

You can press the "Menu" button continuously to enter into "MENU 3". Information about the deuterium lamp can be found here, including: the switch state, running time, start times, etc.. By pressing "↑" and "↓" button, the screen shows below in turn.

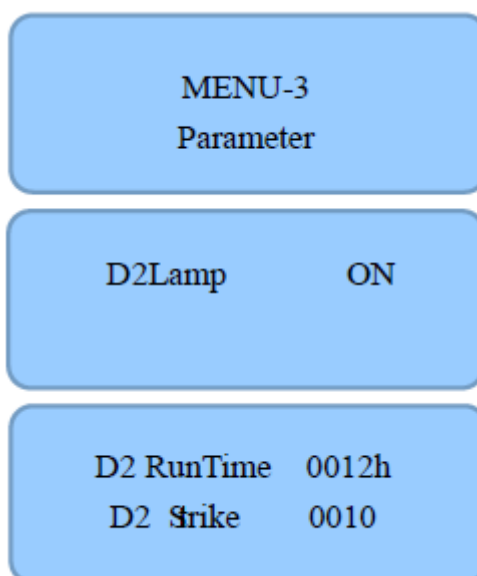

4.5.1 The switch state of deuterium lamp

Through pressing "↑" and "↓" key to enter the following setting interface of deuterium lamp switch state, the cursor blinks after pressing the enter key. You can change the switch state of deuterium lamp using the "↓" button. When deuterium lamp is set to "OFF" state, the front panel indicator lights will go out.



[Caution] The impact to deuterium lamp of each switching on is equal 3 hours normal light. If the interval before next turning on is less than 3 hours, you'd better keep the deuterium lamp on.

If the state of deuterium lamp is "OFF" before the last power off, hint will occur to remind of it after the detector is turning on, you can set it following "4.5.1".

4.5.2 The running time of deuterium lamp

User can view the running time through pressing "↑" and "↓" key, but can not change it.

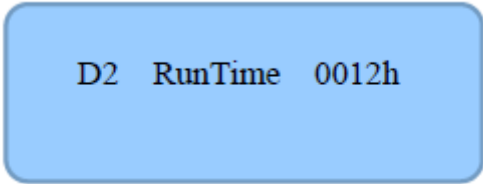

4.5.3 Number of deuterium lamp open

User can view the number of deuterium lamp open through pressing "↑" and "↓" key, but can not change it.

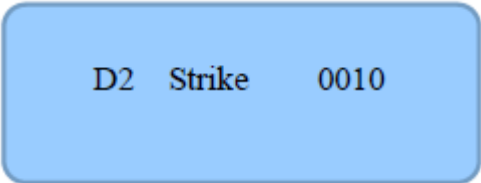

4.5.4 The energy of deuterium lamp

User can view the energy of deuterium lamp open through pressing "Energy" key on the front panel, but can not change it. "Smp" is measured value, "Ref" is reference value.

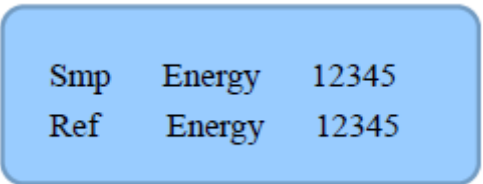

[Caution] "Smp Energy" is related to detect wavelength, the location of flow cell, mobile phase condition and other factors. If the "Smp Energy" is too low, maybe there is bubbles in the flow cell or the pool position is not right, please exhaust bubbles and screw down the flow cell. A big Mobile phase absorption value can also lead to Smp value to be small, especially when the detection wavelength is less than 220nm, Please choose optimal chromatographic pure grade solvent(methanol and acetonitrile).

Ref value is related to the running time and number of open of deuterium lamp.

The running time, number of open and energy values can not be changed.

5. Chapter Five: Maintenance and Repair

5.1 Cleaning the flow cell

In use of detector flow cell is easily polluted by mobile phase, chromatographic packing, samples etc., so, cleaning the flow cell is very important. Figure 5-1 is assembly diagram of D1100 flow cell.

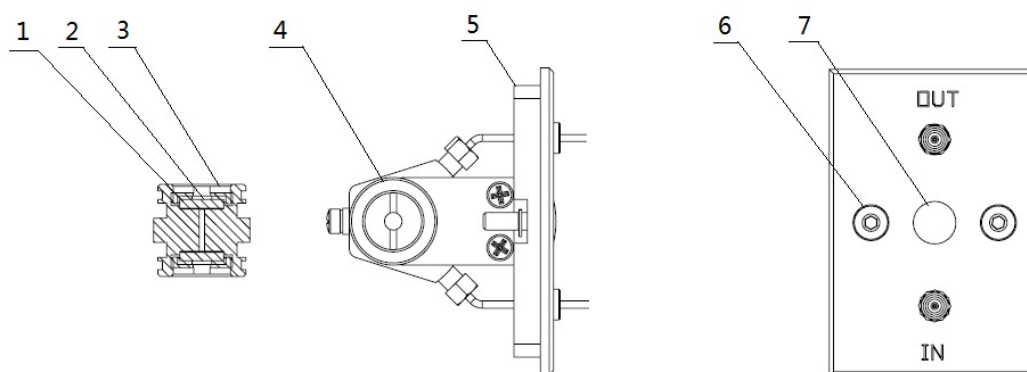

Figure 5-1: D1100 flow cell assembly diagram

1. Cell glass, 2. Gland nut washers, 3. Gland nut, 4. Flow cell body, 5. Front board of flow cell, 6. Front board screw, 7. Flow cell body screw

Disassembly process is as follows:

- 1) Unscrew the two front board screw(6#) with hex wrench, pull the flow cell from detector.
- 2) Loosen nut.(3#) with a screwdriver, remove gland nut washers(2#), cell glass(1#) in turn. Operate the other side with the same method.

Cleaning process is as follows:

Cleaning the parts of flow cell. immerse the parts in a beaker with 1:4 nitric acid solution (v/v), Sonicate them for a few minutes, and then wash them with water and methanol solution respectively. After cleaning, you should reassemble these parts, put the flow cell into detector, and tighten the screws. Please put the cell glass and gasket properly, So as not to crush the cell glass or causing the cell leakage.



[Caution] The cell glass is fragile, and it is beyond the scope of instrument maintenance.

5.2 Deuterium lamp replacement

The normal service life of D1100 deuterium lamp can be more than 1500 hours. The service life of the lamp is associated with the use time and the switch frequency, so in the process of using, you'd better try to save unnecessary boot time, reduce the frequency of switch. If the deuterium lamp couldn't light or energy is too low, you need to replace new deuterium lamp. Replacement method and steps are as follows:

The deuterium lamp replacement (refer to figure 5):

- 1) Shutdown the detector, unplug the power cord, open the chassis, and waiting for deuterium lamp cools, remove the three connection of deuterium lamp from the fixed frame with a phillips screwdriver (pay attention to remember the location of the red line), take the two fix screw down from the lamp holder, gently pull the old lamp out.
- 2) Confirm the type of the new lamp is the same as the old one.
- 3) Put the new lamp into lamp holder gently, tighten the two fix screw, connect the three light cable on the terminal. (The position of the lines should be the same as old one).
- 4) Check the lamp wire to confirm it is connected correctly.

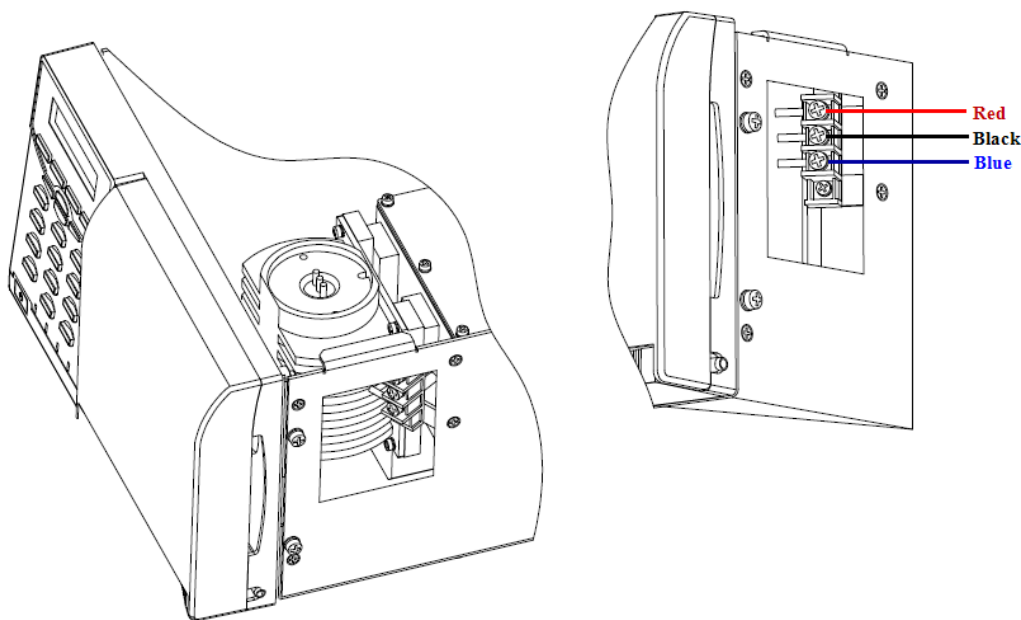

Figure5-2: Deuterium lamp installation diagram



[Caution] Ban charged deuterium lamp replacement.

When the deuterium lamp is light, it will emit strong ultraviolet ray, which can damage eyes and skin. Never observe a light deuterium lamp with naked eye. Please put on UV protective goggles while observing it.

Please wear clean gloves when operating, in order to avoid lamp pollution. If there is oil stains, hand lines or dust on the lamp shell, clean it with ethanol, otherwise it is difficult to remove after deuterium lamp glow, the contamination on the lamp shell will influence the intensity of light.

Lead with red sleeve is the high tension line, please connect it on the red wire terminals. Do not connect it wrong, otherwise the deuterium lamp is easy to burn.

The type of deuterium lamp must be prescribed.

5.3 Common failure diagnosis and elimination

The use of chromatograph involves machinery, electronics, optics and computer knowledge.

When the instrument is abnormal in the process of running, please check in the following way.

Table 5-1: A summary of most common problems affecting system operation

Symptoms	cause	Solution
Noise	Detector flow cell contaminated	Wash the flow cell with 1mol/L nitric acid, water, and a new solvent. Unload the flow cell, clean or replace quartz window of it.
	Air bubbles in detector flow cell	Increase the flow rate suddenly, drive out the bubbles. Connect a back pressure (0.2-0.3 MPa) parts, or even a stainless steel tube (ID 0.007mm x 0.5-1m) at the outside of the flow cell to increase the pressure in the flow cell.
	detector or data acquisition system improperly grounded.	Take away the original grounding line, to reconnect.
	Detector lamp failure	Check the deuterium lamp set state; Check that the light use time, light energy, opening times; Replace the deuterium lamp.
	Fluid leakage	Tighten or replace the fittings
	Small bubbles traveling through the flow cell	Degas the mobile phase carefully; Increase the back pressure of the cell.
	Particles in detector flow cell.	Cleaning the cell; Check the sieve plate of column exports.

Symptoms	cause	Solution
Baseline drift	Detector flow cell contaminated	Wash the flow cell with 1 mol/L nitric acid, water, and a new solvent. Unload the flow cell, clean or replace quartz window of it.
	Chromatographic column contamination or loss of stationary phase	Clean or exchange the column. Use protect column.
	The cell leakage	Change quartz window of flow cell. Tighten gland nut
	Detector temperature changes	Make the system temperature constant
	Detector lamp failure	Replace the deuterium lamp
	The original mobile phase was not fully removed	Thoroughly replace the system with new mobile phase or compatible solvent
	Solvent storage bottle contamination	Clean the solvent bottle, equilibrate system with a new mobile phase
	Strong adsorption component is eluted from the column	Flush the column with strong elution solvent before the next separation. Use solvent gradient
Noise spikes	Small bubbles traveling through the flow cell	Degas the mobile phase carefully; decrease the temperature around
	Detector or data acquisition system improperly grounded.	Take away the original grounding line, and reconnect it.
Negative peaks	Polarity of output signal is not correct	Reverse detector output signal wiring
	Sample injection failure	Use injection valve, confirm there is no air bubbles in sample ring during injection
	The mobile phase is not pure	Use chromatographic pure mobile phase, or purify the solvents
Signal stepped up; Flat peak; The baseline can't back to zero	Improper recorder gain and damping control;	Adjust the gain and damping; Repair the recorder
	Incorrect detector setting of output range.	Reset the detector output range
	Detector or data acquisition system improperly grounded.	Take away the original grounding line, and reconnect it.
Recorder, integrator or workstation is not balance in zero	Fault recorder, integrator or workstation	maintain
	Small bubbles in the flow cell	Degas the mobile phase carefully; Increase the back pressure of the cell.
	The energy of light out from flow cell is weak	Check the light path, unclog. Clean the flow cell or replace cell window
	Detector lamp failure	Replace the deuterium lamp.
	Poor contact between the detector, recorder, integrator or workstation	Check and tighten connection wire
	The column stationary phase erosion is serious	Replace the column; Change the mobile phase
	The original mobile phase contamination	Rinse the system thoroughly
	Mobile phase absorption is too strong	Convert ultraviolet through solvent; Change detection wavelength

Symptoms	cause	Solution
Baseline noise arise along with the pump reciprocating	Strong air or fluid pulsation is around the instrument	place the instrument in right environment. Reduce the pulsation of the pump with a regulator or damper
noise spikes arise along with the pump reciprocating	Air bubbles in flow cell	Unload the column, impel methanol from outlet of detector with a syringe to remove air bubbles
Detector is not working	fuse burn-out	replace fuse
	The power supply is turned off	Turn on the power supply
Light for deuterium lamp is not bright	End of deuterium lamp life	Replace deuterium lamp
	Improper deuterium lamp connection	rewiring
	The power supply problem	Check the power supply
	deuterium lamp is turned off	Turn on the deuterium lam
Samples and reference the energy display to zero	Deuterium lamp burnt	Replace deuterium lamp
	The power supply problem	Check the power supply

Appendix

Consumption parts

NO.	Describe	PN
1	PEEK blade ring	14990128
2	Column clamp	14992584
3	Flat wire clip	14992562
4	Clamp parts	14992427
5	The black cross trough screw	14992209
6	Silicone tube	13010033
7	USB line	17000045
8	Power line	17000001
9	T1.0A/250V fuse	15080014
10	Deuterium lamp	16010008

Safety information

General safety information

At different stages of the instrument operation, maintenance and repair, everyone should abide the following general safety rules, breaking these rules may cause damage to instruments or staffs, Elite Analytical Instruments Co., Ltd. does not responsible for the impact caused by non-standard operation.

Standard of security

For marked with this symbol of the equipment, the user should refer to the instruction manual, so as not to cause harm to the operator and equipment damage.

Symbol	Description
	Please do not operate beyond the scope of caution, unless you have been fully understand and meet the required conditions.
[Warning]	Casualties may appear. Please do not operate beyond the scope of warning, unless you have been fully understand and meet the required conditions.
[Caution]	Data loss or equipment damage may appear. Please do not operate beyond the scope of caution, unless you have fully understood and met the required conditions.
[Note]	Unsatisfactory experimental data and instrument failure may appear. Please do not operate beyond the scope of note, unless you have been fully understand and meet the required conditions.

Absorptive character of some typical functional groups

Name	Groups	λ_{max}	ϵ_{max}	λ_{max}	ϵ_{max}	λ_{max}	ϵ_{max}
ether	-O-	185	1000				
thioether	-S-	194	4600	215	1600		
amine	-NH ₂	195	2800				
mercaptan	-SH	195	1400				
disulphide	-S-S-	194	5500	255	400		
bromide	-Br	208	300				
monoiodide	-I	260	400				
oximido	-NOH	190	5000				
nitrine	>C=N-	190	5000				
ethylene	-C=C-	190	8000				
keto-	>C=O	195	1000				
thioketone	>C=S	205	Strong	270-285	18-30		
aldehyde	-CHO	210	Strong				
acid	-COOH	200-210	50-70				
sulfoxide	>S→O	210	1500				
nitro	-NO ₂	210	Strong				
Nitrous acid ester	-ONO-	220-230	1000-2000				
	(no-loop)						
	-(C=C) ₃ -	260	25000				
	-(C=C) ₄ -	300	52000				
	-(C=C) ₆ -	330	118000				
	-(C=C) ₈ -	230-260	3000-8000				
	(annulate)						
	C=C-C≡C	219	6500				
	C=C-C=N	220	23000				
	C=C-C=O	210-250	10000-20000				
	C=C-NO ₂	229	9500				
benzene		184	46700	202	6900	255	170
biphenyl		246	20000				
naphthalene		220	112000	275	5600	312	175
anthracene		252	199000	375	7900		
pyridine		174	80000	195	6000	251	1700
quinoline		227	37000	270	3600	314	2750
isoquinoline		218	80000	266	4000	317	3500

【State】 When choosing the best absorption wavelength, the lowest wavelength getting through mobile phase ought to be considered at the same time (UV cutoff wavelength in the appendix 2). To sample who have multiple characteristic absorption wavelength, the wavelength corresponding to the biggest ϵ_{max} is the best choice.

Features of some organic solvents

	Solvent* 7<.5cP,<45	source	UV Cutoff	R.I. 25°C	boiling point °C	viscosity cP,25°C	p'	ea	w%	e	p'+ 0.25e
1	FC-78* FC-75(fluorous solvent) F-43	LC chara cter	210 (Opaque or below)	1.267 1.276 1.291	50 102 174	0.4 0.8 2.6	< -2 < -2 < -2	-.25 -.25 -.25		1.88 1.86 1.9	p' And the dielectric constant
2	isooctane*	LC	197	1.389	99	0.47	0.1	0.01	0.011	1.94	0.1
3	n-heptane*	LC	195	1.385	98	0.40	0.2	0.01	0.010	1.92	0.5
4	n-hexane*	LC	190	1.372	69	0.30	0.1	0.01	0.010	1.88	0.5
5	n-pentane**	LC	195	1.355	36	0.22	0.0	0.00	0.010	1.84	0.5
6	cyclohexane	LC	200	1.423	81	0.90	-0.2	0.04	0.012	2.02	0.5
7	cyclopentane	LC	200	1.404	49	0.42	-0.2	0.05	0.014	1.97	0.6
8	1-chlorobutane*	LC	220	1.400	78	0.42	1.0	0.26		7.4	2.8
9	carbon disulfide	LC	380	1.642	46	0.34	0.3	0.15	0.005	2.64	1.7
10	2- chloride**	LC	230	1.375	36	0.30	1.2	0.29		9.82	3.7
11	carbon tetrachloride	LC	265	1.457	77	0.90	1.6	0.18	0.008	2.24	2.3
12	n-butyl ether		220	1.397	142	0.64	2.1	0.25	0.19	2.8	2.4
13	triethylamine			1.398	89	0.36	1.9	0.54		2.4	2.4
14	bromoethane*			1.421	38	0.38	2.0	0.35		9.4	4.3
15	isopropyl ether*		220	1.365	58	0.38	2.4	0.28	0.62	3.9	3.2
16	methylbenzene	LC	285	1.494	110	0.55	2.4	0.29	0.046	2.4	2.9
17	P-xylene		290	1.493	138	0.60	2.5	0.26		2.3	3.0
18	chlorobenzene			1.521	132	0.75	2.7	0.30		5.6	4.1
19	bromobenzene			1.557	156	1.04	2.7	0.32		5.4	4.1
20	iodobenzene						2.8	0.35			
21	diphenyl ether			1.580	258	3.3	3.4			3.7	3.7
22	phenetole			1.505	170	1.14	3.3			4.2	4.9
23	diethyl ether*	LC	218	1.350	35	0.24	2.8	0.38	1.3	4.3	4.0
24	benzene	LC	280	1.498	80	0.60	2.7	0.32	0.058	2.3	3.6
25	phosphotriester(p-to lyl)			1.510	72	0.57	2.2			7.8	4.2
26	iodoethane			1.510	72	0.57	2.2			7.8	4.2
27	n-caprylic alcohol		205	1.427	195	7.3	3.4	0.5	3.9	10.3	5.8
28	fluorobenzene			1.46	85	0.55	3.1			5.4	4.6
29	benzyl oxide			1.538	288	4.5	4.1				
30	dichloromethane**	LC	233	1.421	40	0.41	3.1	0.42	0.17	8.9	5.6
31	anisole			1.514	154	0.9	2.8			4.3	4.6
32	isoamyl alcohol			1.405	130	3.5	3.7	0.61	92	14.7	7.3
33	,2-Dichloroethane	LC	228	1.442	83	0.78	3.5	0.44	0.16	10.4	6.3
34	tert-butyl alcohol			1.385	82	3.6	4.1	0.7	Dissolved	12.5	
35	n-butyl alcohol	LC	210	1.397	118	2.6	3.9	0.7	20.1	17.5	8.3
36	n-propyl alcohol	LC	240	1.385	97	1.9	4.0	0.82	Dissolved	20.3	
37	tetrahydrofuran*	LC	212	1.405	66	0.46	4.0	0.57	Dissolved	7.6	
38	propylamine*			1.385	48	0.35	4.2		Dissolved	5.3	
39	ethyl acetate	LC	256	1.370	77	0.43	4.4	0.58	8.8	6.0	5.8
40	isopropyl alcohol	LC	205	1.384	82	1.9	3.9	0.82	Dissolved	20.3	

	Solvent* 7<.5cP,<45	source	UV Cutoff	R.I. 25°C	boiling point °C	viscosity cP,25°C	p'	ea	w%	e	p'+ 0.25e
41	chloroform*	LC	245	1.443	61	0.53	4.1	0.40	0.072	4.8	5.6
42	acetophenone			1.532	202	4.8				17.4	8.7
43	MEK*	LC	329	1.376	80	0.38	4.7	0.51	23.4	18.3	9.1
44	cyclohexanone		215	1.450	156	20	4.7			18.3	9.1
45	nitrobenzene			1.550	211	1.8	4.4			34.8	13.2
46	phenyl cyanide			1.536	191	4.8				25.2	10.9
47	dioxane	LC	215	1.420	101	1.2	4.8		Dissolved	2.2	
48	tetramethylurea	LC	265	1.449	175		6.0	0.56		23.0	10.7
49	quinoline			1.625	237	3.4	5.0			9.0	7.4
50	pyridine			1.507	115	0.88	5.3		Dissolved	12.4	
51	nitroethane		380	1.390	114	0.64	5.2		0.9		
52	acetone*	LC	330	1.356	56	0.30	5.1	0.71	Dissolved		
53	phenethyl alcohol			1.538	205	5.5	5.7			13.1	8.8
54	tetramethyl guanidine						6.1	0.6			
55	methyl cellosolve	LC	210	1.400	125	1.60	5.5		Dissolved	19.9	
56	CIS Cyanide Oxide	GC					6.6				
57	1,2-Propyl carbonate	LC					6.1				
58	ethyl alcohol	LC	210	1.359	78	1.08	4.3		Dissolved	24.6	
59	diether	GC					6.8				
60	aniline			1.584	184	3.77	6.3			6.9	8.1
61	acetic acid			1.370	118	1.1	6.0		Dissolved	6.2	
62	acetonitrile*	LC	190	1.341	82	0.34	5.8		Dissolved	37.5	
63	dimethylacetamide	LC	268	1.436	166	0.78	6.5	0.88		37.8	
64	dimethylformamide	LC	268	1.428	153	0.80	6.4			36.7	
65	dimethyl sulfoxide	LC	268	1.477	189	2.00	7.2	0.62	Dissolved	4.7	
66	N-methyl-2-pyrrolidone	LC	285	1.468	202	1.67	6.7			32	
67	Hexamethylphosphoric triamide			1.457	233	3	7.4	0.65		30	
68	methyl alcohol*	LC	205	1.326	65	0.54	5.1		Dissolved	32.7	
69	nitromethane		380	1.380	101	0.61	6.0		2.1		
70	m-cresol			1.540	202	14	7.4			11.8	10.0
71	n-methyl formamide			1.447	182	1.65	6.0		Dissolved	182	
72	ethanediol			1.431	182	16.5	6.9		Dissolved	37.7	
73	methyl aldehyde			1.447	210	3.3	9.6		Dissolved	111	
74	water	LC		1.333	100	0.89	10.2			80	

【State】

1. Organic solvent have low boiling point ($\leq 45\text{ }^{\circ}\text{C}$), low viscosity ($\leq 0.5\text{cp}$) is easy to use. Marked with (*) number of organic solvents is preferred for high performance liquid chromatography (HPLC) mobile phase solvent. Marked with (***) is with very low boiling point and low viscosity solvent.

2. In the "source" column with LC means the mobile phase can be purchased from the following companies: Burdick & Jackson, Baker Chemical, Mallinkrodt Chemical, Fischer Scientific, Manufacturing Chemicals, inc. etc..

3. In the "source" column with GC means the mobile phase can be used as gas chromatographic stationary phase, and can be purchased from the distribution company and GC column stationary phase

4. "UV Cutoff" — Mobile phase is ultraviolet transparent over the wavelength

5. "R.I.25" the index of refractive index ($25\text{ }^{\circ}\text{C}$).

6. "p" the polarity parameters of mobile phase.

7. "ea" Flow intensity parameter when alumina is use for liquid - solid adsorption.

8. "w%" Water Solubility w% in $20\text{ }^{\circ}\text{C}$ Solvent.

9. "e" Dielectric Constant e .

10. "p'+0.25E" Electric constant function.

ELITEHPLC

About Elite

Suzhou Elite Science & Technology Co., Ltd.
701#, Building 10, Liandong U Valey, No. 179 Zhujiawan Street,
Gusu District, Suzhou, Jiangsu, China.
Tel: +86-512-67997535
E-mail: info@eliteHPLC.com
Web: <http://www.elitehplc.com>
